

Study on Fatigue Life Prediction of TC4-DT Structural Simulants by Using Critical Distance Theory

Taiyu Piao, Xiaoan Hu

College of Aircraft Power Engineering, Nanchang Hangkong University, Nanchang, China
Email: 2446047057@qq.com

How to cite this paper: Piao, T.Y. and Hu, X.A. (2024) Study on Fatigue Life Prediction of TC4-DT Structural Simulants by Using Critical Distance Theory. *World Journal of Engineering and Technology*, 12, 320-338.

<https://doi.org/10.4236/wjet.2024.122021>

Received: March 18, 2024

Accepted: May 10, 2024

Published: May 13, 2024

Copyright © 2024 by author(s) and Scientific Research Publishing Inc. This work is licensed under the Creative Commons Attribution International License (CC BY 4.0).

<http://creativecommons.org/licenses/by/4.0/>



Open Access

Abstract

In the actual engineering of the structure, mechanical notch is inevitable, which will significantly reduce the fatigue life of the structure. In order to ensure the application of notch structures in engineering, the accurate evaluation of the impact of notch on fatigue life has become the basis of fatigue reliability design of structures. To investigate the influence of the concave structure on the overall fatigue life in practical engineering, three different sizes of V-notch parts and concave structure simulation parts were designed, and the life prediction was carried out by using the critical distance method. The results show that the stress gradient of the concave structure with the same stress concentration coefficient is much greater than that of the V-notch structure. Considering the notch effect, the S-T model in the critical distance method is modified by the stress concentration coefficient and stress gradient, and it is found that the life prediction accuracy reaches the ideal.

Keywords

Notched Fatigue, Critical Distance, Stress Concentration, Stress Gradient

1. Introduction

In practical engineering applications, in order to meet the requirements of weight reduction, there are notches with relief grooves on parts, and the main reason for fatigue failure of the parts is the stress concentration effect caused by the notch. Then, various life prediction methods have been proposed, which take into account local characteristic quantities such as stress, strain and strain energy. Yao [1] applied VonMises stress weighted average in the notch root area to predict the notch life. Visvanatha [2] *et al.* used different local strain estimation

methods to evaluate the fatigue life of 7050-T7451 aluminum alloy. Fricke and Paetzoldt [3] used the local notch stress method to evaluate the fatigue strength of scallops under complex load combinations. Meggiolaro [4] *et al.* calculated the parameters of Manson-Coffin equation treated with 845 metals, and proposed a strain life prediction method for fatigue crack initiation. Among those methods, the TCD (Theory of Critical Distance) has been applied to life estimation under HCF conditions due to its consistent core idea of fatigue failure mechanism, that is, fatigue damage gradually accumulates in the critical region of the stress concentration and eventually reaches the critical value [5].

The TCD can be divided into four categories according to its critical region: the point method (PM) [6], the line method (LM) [7], the area method (AM) [8] and the volume method (VM) [9]. The TCD uses the mean maximum principal stress in the critical region to characterize the fatigue behavior of the components. The determination of the critical distance directly represents the size of the critical region and determines the prediction of life. Susmel and Taylor [10] discovered that the critical distance was closely related to the fatigue life by calibrating the S-N curve of the notched and the plain specimens, which is the most common method for determining the critical distance, especially the Susmel and Taylor (S-T) model used in this work.

The S-T model performed well under a wide range of materials [11] [12] [13] [14] and load conditions (variable stress ratio [10], multi-axial fatigue [15]). Although the S-T model was established based on the fatigue test results of the notched specimens, the model clearly showed that the critical distance was only related to the fatigue life, while the influence of the notch geometry was ignored.

Multiple studies have found that notch type and size have a significant impact on the critical distance [16] [17]. Yang *et al.* [18] proposed that in addition to notch radius, stress concentration factor K_t could also be used to describe the influence of notch size and shape on the critical distance value. But the notch radius and stress concentration coefficient were essentially incompatible. Because the stress concentration coefficients of specimens with the same notch radius might be different, the critical distance values obtained by these methods could be significantly different. In addition, for complex components with irregular notch geometry, the notch radius and stress concentration coefficient were difficult to identify. Therefore, it is necessary to study appropriate structural parameters to characterize the influence of notch geometry on the critical distance. Based on this, the main research content of this paper is to modify the S-T model by using stress concentration coefficient and stress gradient, and apply it to the fatigue life prediction of complex notched components.

2. Critical Distance Determination Methods

The form of the S-T model mentioned earlier is shown below:

$$L = A_1 N_f^{B_1} \quad (1)$$

where L is the critical distance, N_f is the fatigue life, and A_1 and B_1 are the ma-

terial constants that vary only with the stress ratio R . By modifying the S-T model, the life model can reflect the impact of notch effect on critical distance and fatigue life.

2.1. K_t Method

When Yang *et al.* [18] used the TCD method to predict the fatigue life of DZ high-temperature alloy with different notch types, they assumed that the critical distance, which is the product of the stress gradient controlling fatigue behavior at locations with large stress gradients and the stress concentration factor K_p , is a function of fatigue life. Based on this assumption, they conducted related research. **Figure 1** shows the relationship between critical distance and fatigue life calculated using the traditional critical distance methods PM and LM combined with SWT parameters for DZ125 specimens of different notch types. It can be observed that the critical distance varies with different fatigue lives, consistent with the definition in Equation (1). Then, after modification using K_p , Equation (1) is as follows:

$$K_t \cdot L = A_2 N_f^{B_2} \quad (2)$$

where A_2 and B_2 are the material constants that vary only with the stress ratio R . In this paper, Equation (2) is referred to as the K_t model. Based on Equation (2), combined with fatigue test data, a relationship diagram between critical distance and the product of K_t and fracture life N_f as shown in **Figure 2** is obtained. It can be seen that after modifying the S-T model with K_p , the changing trend of critical distance values for different notches under PM and LM methods is consistent. Therefore, it can be inferred that there may be a correlation between the product of K_t and critical distance and the fatigue life N_f . In practical applications, this method requires two fatigue failure curves for smooth specimens and notched

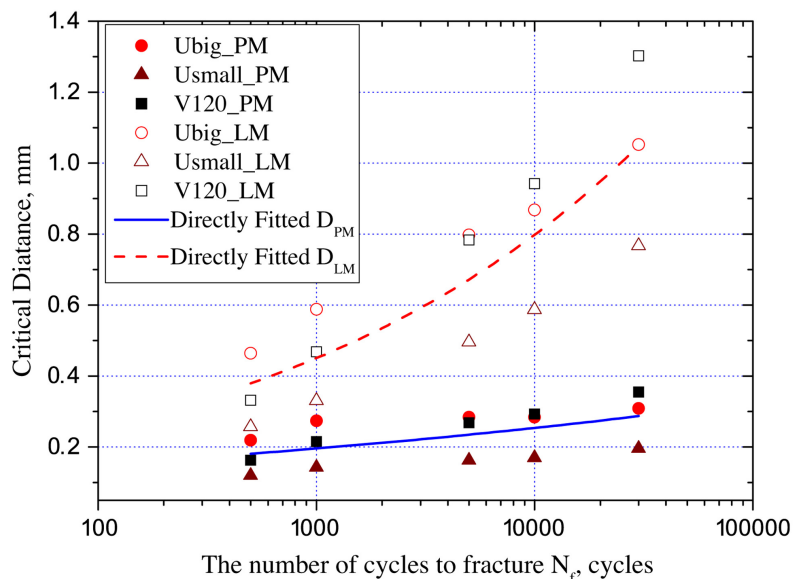

Figure 1. Critical distance based on traditional PM and LM [18].

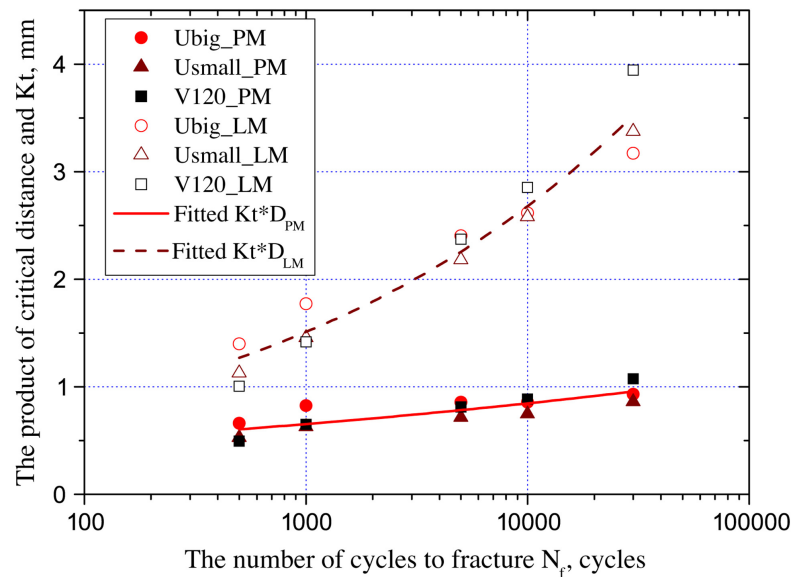

Figure 2. The relationship between the critical distance multiplied by K_t and the fatigue life N_f [18].

specimens, as well as the K_t value determined from elastic finite element analysis. The calculation process is simple.

2.2. New K_t Method

However, in practical engineering, the shapes of various structural components vary greatly, and their sizes and processing methods also differ. The fatigue life of structures is affected by factors such as stress concentration, size effect, and surface quality. In order to solve the problem of stress concentration factor for complex engineering structures, finite element numerical methods are used to quantify the effects of stress concentration.

There are two ways to obtain the stress concentration factor: calculation and measurement. The measurement method is based on the measurement of the elastic deformation of the structure, and the commonly used methods include strain measurement and photoelastic measurement. The calculation method includes analytical calculation and finite element numerical calculation. For simple and typical regular notched specimens, there are mature analytical calculation methods available, and for some typical notched structures, stress concentration factor charts have been developed based on loading conditions, which can be directly referred to. However, for most engineering structures with complex and variable shapes and large sizes, it is difficult to perform analytical calculations, so finite element methods can be used for calculation. Using finite element methods to calculate the stress concentration factor is a simple and effective method, especially for the calculation of stress concentration factors in structurally complex shapes. Theoretical stress concentration factor is related to the shape of the structural gap, rather than the material type, and it is also influenced by the type of load. For the same type of gap, the stress concentration factor under ten-

sile load is greater than the stress concentration factor under torsional load. According to the definition, the theoretical stress concentration factor can be expressed as:

$$K_t = \frac{\sigma_{\max}}{\sigma_n} \quad (3)$$

where σ_{\max} represents the local maximum stress (MPa), and σ_n represents the nominal stress (MPa). When using the finite element numerical calculation method for solving, the calculation of nominal stress requires defining the stress integration path. Integration along the stress path is performed to obtain the nominal stress.

$$\sigma_n = \frac{\int \sigma_x dl}{l} \quad (4)$$

where σ_x refers to the stress (MPa) defined on the path, and l refers to the path length (mm). The approximate process of calculating the stress concentration factor of the structure using the finite element method is as follows:

- 1) Perform finite element stress analysis on the structure to determine the critical and stress-concentrated positions of the structure.
- 2) Extract the maximum stress σ_{\max} of the analyzed local area.
- 3) Define an integration path l , extract the stress values of the nodes on the integration path, and fit to obtain the stress field near the notch.
- 4) Use Equations (3) and (4) to calculate the theoretical stress concentration factor.

After obtaining the new stress concentration factor K_t' according to the above process, and substituting it into Equation (2), the new K_t' model applied to complex notched structures can be obtained.

$$K_t' \cdot L = A_3 N_f^{B_3} \quad (5)$$

where A_3 and B_3 are material constants changing with the stress ratio.

2.3. Stress Gradient Method

When evaluating the fatigue strength of a notch, besides K_t , another important influencing factor is the stress gradient. The stress gradient refers to the distribution of stress from the surface to the interior of the material and is closely related to stress concentration.

By using the analytical solution of the stress field at the notch provided by Neuber and Ling, Filippini [19] was able to calculate the relative stress gradient at the notch tip of the plate specimen. It was found that the relative stress gradient is directly related to the notch radius and is also influenced by other structural parameters representing the notch shape, such as plate width and notch depth. The stress gradient plays an important role in the fatigue fracture process. According to some studies on microstructural fatigue and notch fatigue crack initiation and propagation, the higher the stress gradient, the higher the stress required for crack initiation, and the lower the driving force for crack propaga-

tion at the notch, resulting in a slower crack growth rate. Therefore, introducing the stress gradient into the S-T model to quantify the influence of notch geometric differences on the critical distance and predict fatigue life seems to be a feasible strategy. The relative stress gradient χ was proposed based on the stress distribution along the bisector of the symmetrical specimens. According to the method proposed by Siebel [20], the ratio of stress concentration factor K_t to fatigue notch factor K_f was a function of the relative stress gradient, which was expressed as:

$$\chi = \frac{1}{\sigma_{\max}} \frac{d\sigma}{dx} \quad (6)$$

As suggested by Shen *et al.* [21], the stress gradient on the critical region can be used for asymmetric specimens with irregular notch features, and it is defined as the derivative of the average stress on the region with respect to the characteristic length of the region. Since the stress gradient only depends on the geometric features of the notch, the critical distance R_{cr} is used as the characteristic length. The effective stress of TCD is normalized by the local maximum stress σ_{\max} , that is, the regularized average stress η in the equation.

$$\eta = \frac{\sigma_{av}(R_{cr})}{\sigma_{\max}} \quad (7)$$

where R_{cr} is the radius of the semicircle in the critical region taken near the root of the notch. This is the fundamental concept of the critical interface method AM. Shen *et al.* [22] obtained the average stress gradient χ_{cr} by using Equation (7) when predicting the lifetime of low carbon steel and aluminum alloy samples with different types of notches.

$$\chi_{cr} = \left. \frac{d\eta}{dR_{cr}} \right|_{R_{cr}=0} \quad (8)$$

Research had found that the numerical difference of the average stress gradient χ_{cr} indicated its advantage in reflecting the geometric shape of the notch. Changing the type or radius of the notch would result in different χ_{cr} values. When incorporating the average stress gradient into the S-T model, it is important to note that the critical distance and fatigue life have a power function relationship and are strongly influenced by the geometry of the notch. Therefore, the modified model is as follows:

$$L = A_4 (\chi_{cr} \cdot N_f)^{B_4} \quad (9)$$

where A_4 and B_4 are material constants varying with the stress ratio. Equation (9) is referred to as the χ model in this article.

3. Geometry of the Specimens and Finite Element Analysis

3.1. Geometry of the Specimens

The several types of samples used in this paper are TC4-DT alloy, and their material properties are shown in **Table 1**. The fatigue test of this article is carried

out using a servo-hydraulic fatigue testing machine (Instron 8801). The dynamic load range of the equipment is ± 100 kN. Considering the equipment load range, the actual size of the components is subject to certain limitations. The displacement accuracy of the equipment is within $\pm 0.5\%$ of the full stroke, and the load accuracy is within $\pm 0.005\%$ of the full scale of the load sensor or within $\pm 0.5\%$ of the indicated value. The dimensions of the simulated component designed can be seen in **Figure 3**.

To explore the difference between the notch effect resulting from stress concentration in relief groove structure and general notches, this study designed a V-shaped general notch specimen, as shown in **Figure 4**. Three V-notch specimens with different K_t values were designed in this study, with K_t values of 2, 2.4, and 3, respectively. The corresponding notch sizes for each K_t are shown in **Table 2**. It is worth noting that the V-notch specimen with a K_t value of 2.4 was designed for comparison with the relief groove structure. Under similar K_t values, it is necessary to further investigate the differences between stress concentration effects and stress distribution at the notch root (**Table 2**).

Table 1. Material properties of TC4-DT.

Density (kg/m ³)	Elasticity Modulus (MPa)	Poisson's rate	Yield stress (MPa)
4500	110,000	0.342	822

Table 2. The Notch sizes of V-notch sample.

K_t	radius/mm	depth/mm
2	1.5	4
2.4	2.5	5.5
3	1	5

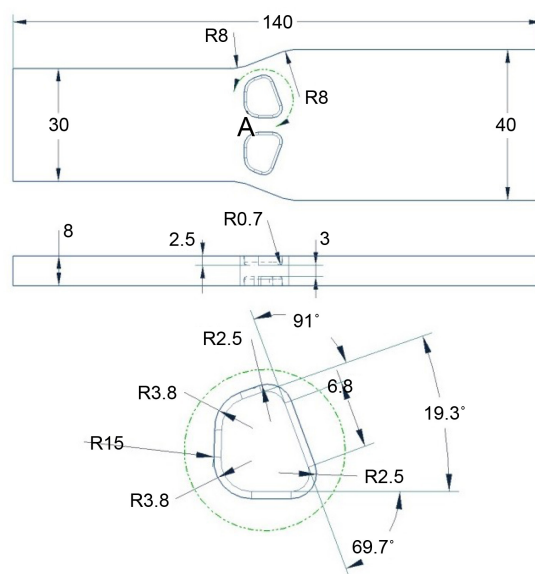

Figure 3. The geometry of the relief groove structure sample.

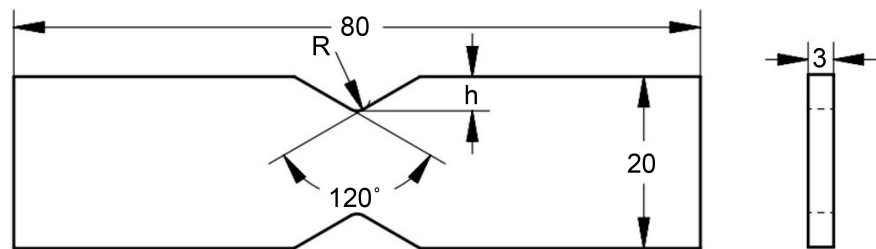

Figure 4. The geometry of the V-notch sample.

3.2. Finite Element Analysis

Using the finite element software to simulate the linear elastic tension of the specimen, it was found that the stress distribution at the point of maximum principal stress is shown in **Figure 5**. It can be seen that the maximum principal stress point appears near the transition zone, and the stress gradient is large, but it cannot be determined whether it is located at the minimum cross-sectional area. Therefore, based on the simulation results, the exact position of the maximum principal stress point is determined, and the cross-sectional area at the maximum principal stress point is determined by the method shown in **Figure 6**. The horizontal axis represents the distance from the end of the specimen, and the vertical axis represents the cross-sectional area at the corresponding position. Based on the calculation, it is found that the maximum local stress occurs at a distance of 61.7 mm from the end (wide side). This corresponds to the fillet transition of relief groove, and the cross-sectional area of the specimen at this time is 180.3 mm². By conversion, when a tensile load of 100 MPa is applied at the end, the nominal stress is 133 MPa. Therefore, the K_t value of the simulated specimen with the relief groove structure is determined to be 2.43. It should be noted that the minimum cross-sectional area of the specimen is 160.08 mm², but this section is located in the middle of the relief groove, where stress concentration is small, so the cross-sectional area at this location is not considered. The maximum principal stress point does not appear at the minimum cross-sectional area, but at the edge of the relief groove transition zone and near the root of the notch. Therefore, it can be considered that the position of the maximum principal stress point has been shifted due to the stress concentration effect and the influence of stress gradient caused by the relief groove structure. It is worth noting that the stress gradient at the maximum principal stress point is not uniformly distributed along the thickness direction, but has a certain angle with the thickness direction. This will require re-planning the stress distribution extraction path for subsequent fatigue life prediction, in order to calculate the critical distance.

4. Life Prediction by the TCD

4.1. Fatigue Test Result

During the fatigue testing of structural components, the experimental results are

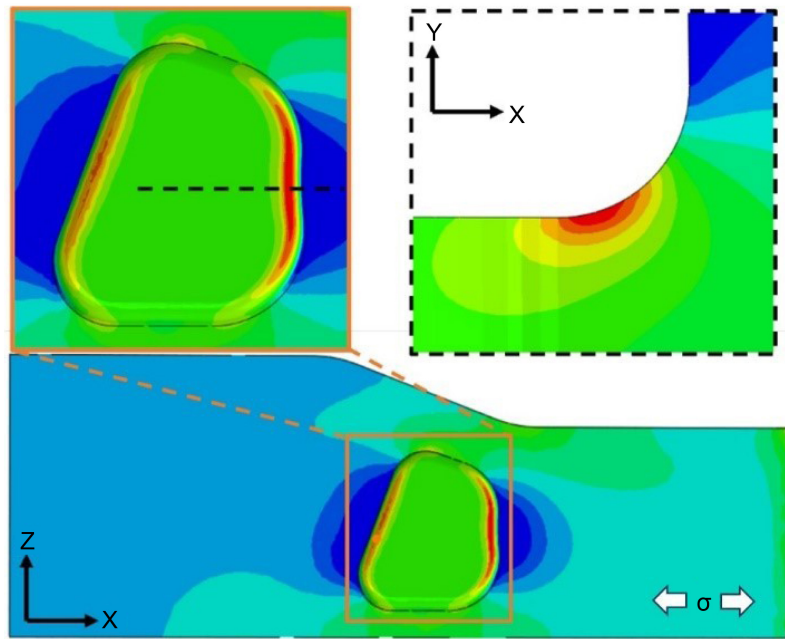

Figure 5. Linear elastic tensile simulation results of relief groove structure.

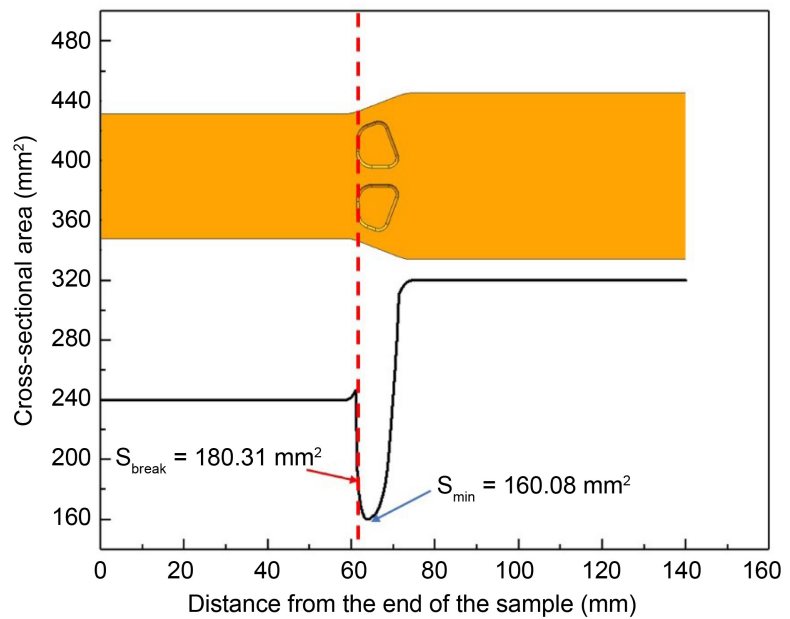

Figure 6. The cross-sectional area at the maximum main stress point of relief groove structure.

shown in **Figure 7**. In the course of the experiment, the fatigue life of specimen TC4-DT-16 reached 1.73×10^6 cycles, exceeding the service life of the aircraft. Therefore, the fatigue test for this specimen was terminated. At a maximum nominal stress of 387 MPa, the fatigue life is approximately 30,000 to 50,000 cycles. As the nominal stress decreases, the high cycle fatigue life increases. When the maximum nominal stress is around 249 MPa, the fatigue life reaches 250,000 cycles. The fatigue test data for V-notch specimens are shown in **Table 3**.

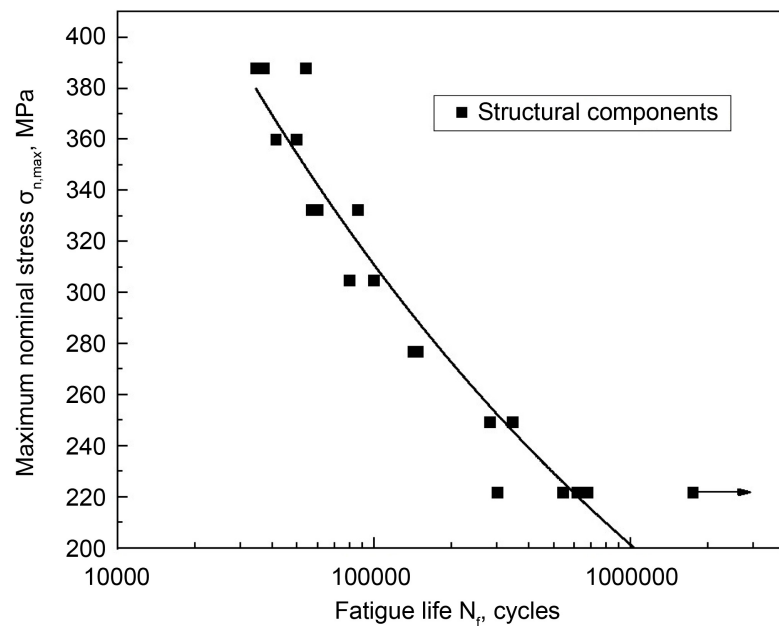

Figure 7. S-N curve of the relief groove structure samples.

Table 3. Fatigue test data of V-notch samples.

K_t	$\sigma_{n,max}$	σ_{max}	N_f
2.0	370.3	740.3	47,476
	333.3	666.7	63,026
	296.3	592.6	132,232
	259.3	518.7	128,438
	222.3	444.5	237,284
	185.3	370.2	577,123
2.4	277.8	666.7	46,144
	250.0	600.0	53,055
	222.2	533.3	164,990
	194.4	466.6	208,788
	166.7	400.1	565,518
3.0	266.7	801.5	65,467
	233.3	699.7	63,300
	200.0	602.4	97,115
	166.7	503.8	279,673
	133.3	359.1	552,135

4.2. Notch Root Stress Distribution

From **Figure 8**, unlike the general phenomenon where the maximum principal stress of the general notch specimen is consistent with the loading direction, the direction of the maximum principal stress at the root of the relief groove struc-

ture simulation component forms a certain angle with the loading direction. This is the effect brought by the relief groove structure. Therefore, when extracting the stress distribution near the root of the gap, the selection of the path needs to consider the influence of stress gradient. The larger the stress gradient, the greater the impact on fatigue life, so the selected path is shown in **Figure 8**. By comparing the stress distribution in **Figure 5**, the selected path is the direction with the maximum stress gradient. The TCD considers the damage caused by the maximum principal stress during fatigue. Although the direction of the maximum principal stress is different from the loading direction, only the magnitude of the maximum principal stress needs to be considered.

After normalizing the stress at a certain load level, extract and observe the stress distribution near the notch of the gap by following the path illustrated in **Figure 8**, as shown in **Figure 9**. The maximum principal stress of the groove

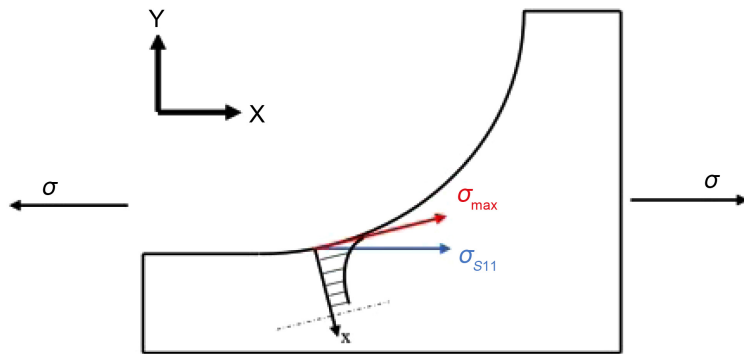

Figure 8. Maximum principal stress distribution at the notch root of the relief groove.

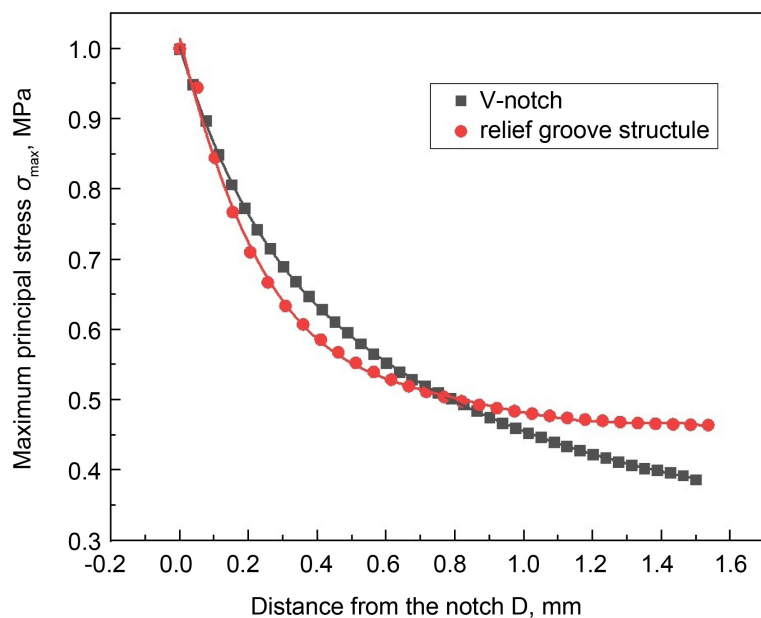

Figure 9. Stress distribution of notched root of V-notch samples and relief groove structural samples with K_t value of 2.4.

structural exists on the surface of the specimen, and there is a significant stress gradient from the notch root to the area 0.4 mm away from it, which makes stress within this range plays a major role in the fatigue life damage during fatigue testing. Although the K_t value of the V-notch specimen is the same as that of the relief groove structural, the stress gradient within the region from the notch root to 0.4 mm away from it is much smaller for the V-notch specimen. It is evident that even though the size of the two specimens is different while the K_t values are similar. Consequently, it can be concluded that the influence of the size of the transition zone, specifically the size of the notch root, is mainly reflected in the stress concentration effect, while the change trend of the stress gradient is determined by the overall structure of the notch.

4.3. Critical Distance Determination

The relationship diagram shown in **Figure 10** is obtained by combining the fatigue life data of the test specimen with the stress distribution near the root of the notch at each stress level. Although the K_t value of the relief groove structure is between the three V-notch specimens, it can be seen from the graph that the critical distance of the relief groove structure varies differently with the change of fatigue life compared to the V-notch specimens, which can be inferred to be caused by the difference in structural dimensions. As the life approaches 10^6 , the critical distance value tends to zero, indicating that as the life increases, the influence of the notch effect gradually decreases. **Figure 11**, obtained based on Equation (2), shows the product of K_t and the critical distance value on the x-axis and the fatigue life value on the y-axis. It can be seen that when considering the influence of K_t , the difference between the relief groove structure and the

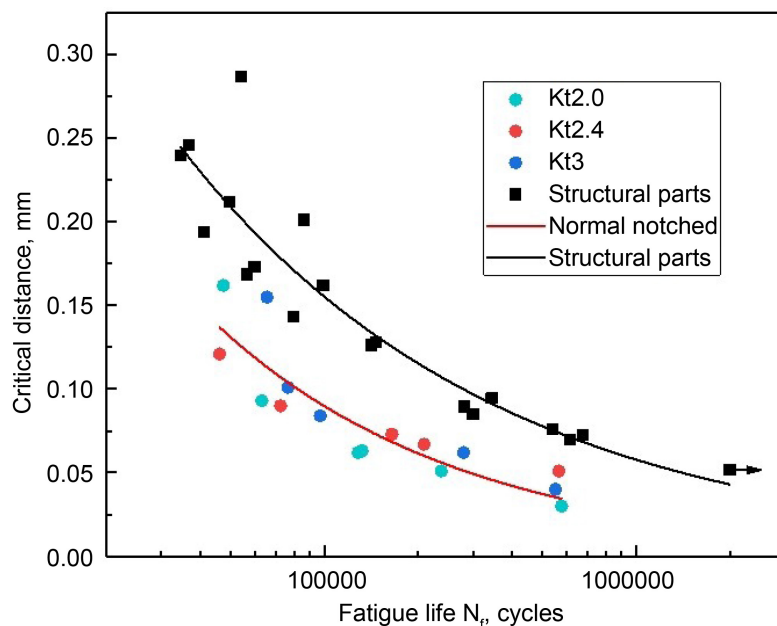

Figure 10. The relationship between critical distance and fatigue life obtained by using S-T model.

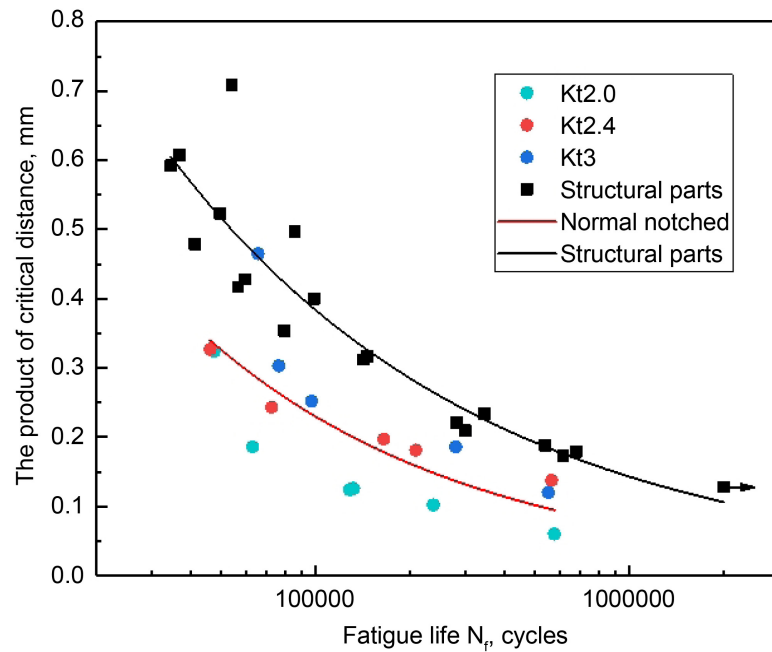

Figure 11. The relationship between critical distance and fatigue life obtained by using K_t model.

V-notch specimens is not greatly improved. It can be speculated that the stress gradient brought by the relief groove structure has a greater impact on this difference than the stress concentration effect. The relationship curve shown in **Figure 12** is obtained by combining Equations (2) and (9), and its form is as follows:

$$K_t \cdot L = A_5 (\chi_{cr} \cdot N_f)^{B_5} \quad (10)$$

where A_5 and B_5 are material constants that vary only with the stress ratio, Equation (10) is referred to as the $K_t\text{-}\chi$ model in this article. The vertical axis in the graph represents the product of K_t and critical distance value, while the horizontal axis represents the product of relative stress gradient and fatigue life value. It can be seen that after considering the effects of stress concentration and stress gradient, there is a significant improvement in the relationship curve between the relief groove structure and the V-notch specimen. Although the K_t value of the mitigated groove structure is similar to that of the V-notch specimen, the stress gradient resulting from different structures is significantly different, indicating completely different stress distribution situations.

The new stress concentration coefficient K_t' was mentioned in the previous article. For the notch of complex structure size, the stress concentration coefficient in the traditional sense may not be applicable, which can be seen in **Figure 13**. After recalculating the theoretical stress concentration coefficient, the K_t value of V-notch specimen has little changed, but that of relief groove structure part is 1.79. Equation (5) was used to redraw the relationship curves between the critical distance and fatigue life of the two kinds of samples, and the relationship

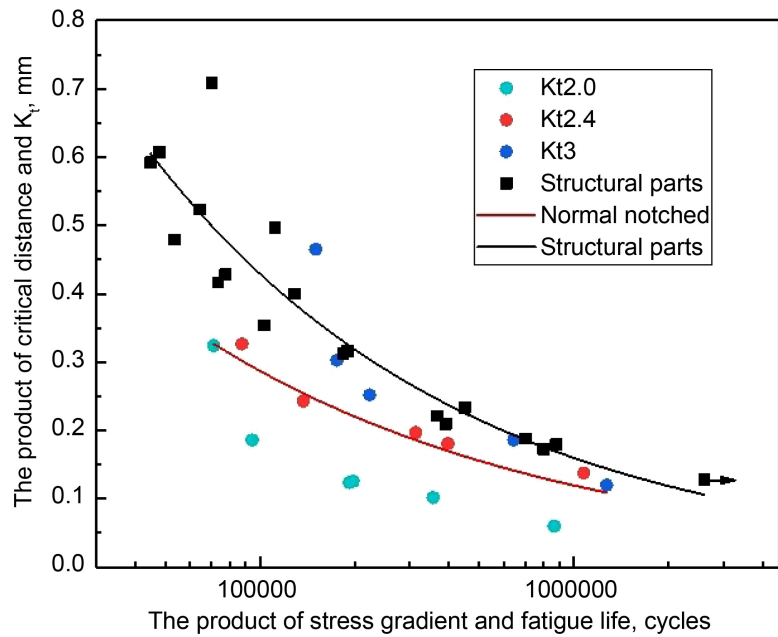

Figure 12. The relationship between critical distance and fatigue life obtained by using $K_t\chi$ model.

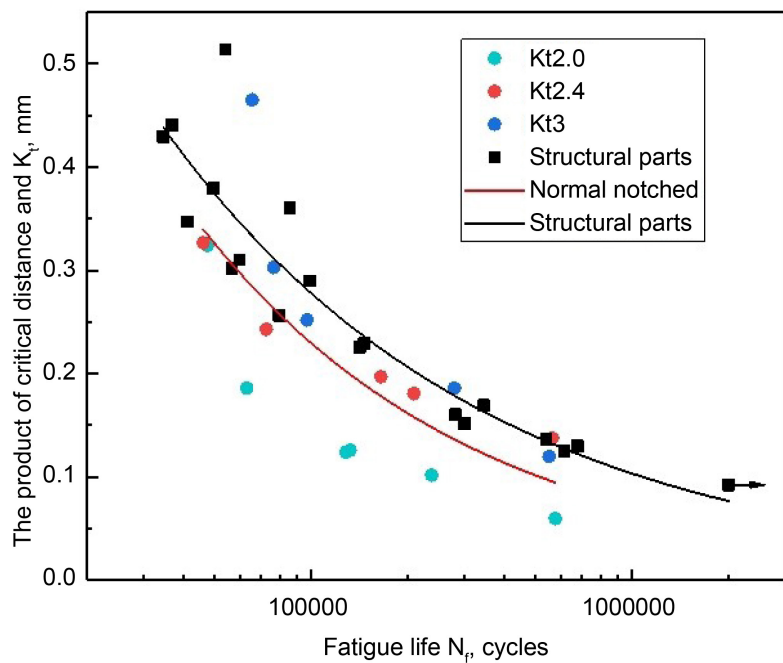

Figure 13. The relationship between critical distance and fatigue life obtained by using K_t' model.

diagram shown in FIG. 13. After the S-T model is modified by applying the theoretical stress concentration coefficient, although the relationship curve of the V-notch specimen remains basically unchanged, the relationship curve of the relief groove structure part is much better fitted with the V-notch specimen. On this basis, the K_t' value is substituted into Equation (5) to obtain the following

relationship:

$$K_t' \cdot L = A_6 (\chi_{cr} \cdot N_f)^{B_6} \quad (11)$$

where A_6 and B_6 are material constants that change with stress ratio, referred to as the K_t' - χ_{cr} model in this paper. The relationship diagram obtained from equation (11) is shown in **Figure 14**, where the relationship curve of the relief groove structure component closely matches the curve of the V-notch specimen. Although the values calculated for the relief groove structure component using the new stress concentration factor K_t' have changed, the data points of the V-notch specimen, which have the same value at the traditional stress concentration factor level, are very close to the data points of the relief groove structure component.

It can be seen from the schematic diagram of the relationship between **Figure 11** and **Figure 14** that although the relationship curve between structural components and V-notch specimen improves after the modification of the S-T model, the relationship between V-notch specimen with different K_t values does not improve as shown in **Figure 2**. The possible reason is that there are too few samples taken for the same K_t value and load level, which leads to the influence of the dispersion of fatigue life.

4.4. Life Prediction

Through the above analysis, the application value of Equation (11) has been proven. First, assume a certain fatigue life value N_f and substitute it into Equation (11) to obtain the corresponding critical distance value L . According to the

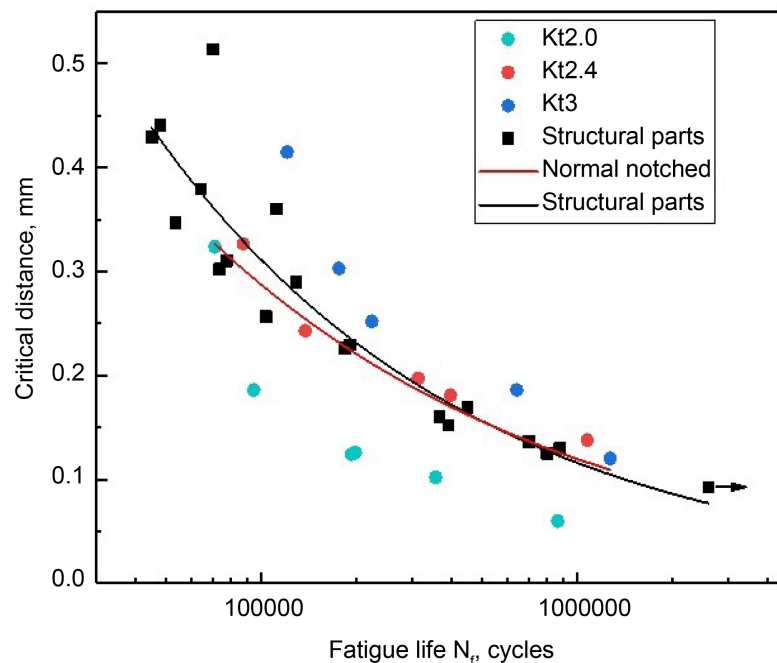

Figure 14. The relationship between critical distance and fatigue life obtained by using K_t' - χ model.

obtained critical distance L and the stress distribution near the notch root, the corresponding effective stress σ_{eff} is obtained. According to the effective stress and the fatigue life curve of the smooth sample material, the fatigue life N_2 is obtained. Next, if the calculated fatigue life N_2 is different from the assumed fatigue life n_1 , make $N_2 = N_{f1}$, and repeat the above process until the problem is terminated when convergence is reached, at which point the obtained fatigue life value N_2 is the predicted fatigue life N_{fp} .

Based on this, a fatigue life prediction analysis is conducted on the unreinforced pressure relief groove structure components, and the life prediction process is shown in **Figure 15**, and the results of life prediction is shown in **Figure 16**. In **Figure 16(a)**, the results of life prediction based on the K_t' model are shown, while in **Figure 16(b)**, the results of life prediction based on the $K_t' - \chi_{cr}$ model are shown. It can be seen that when using the K_t' model for life prediction, all data points fall within the 200% error band, and the majority of data points fall within the 100% error band, with 63% of data points falling within the 50% error band. After using the $K_t' - \chi_{cr}$ model for life prediction, all data points fall within the 100% error band, with 79% of data points falling within the 50% error band. The prediction accuracy of the $K_t' - \chi_{cr}$ model is higher than that of the K_t' model. From **Figure 16(a)**, as the stress level decreases, the trend of data points changes in a non-conservative direction. This may be due to the increase in the dispersion of fatigue life as the stress level decreases.

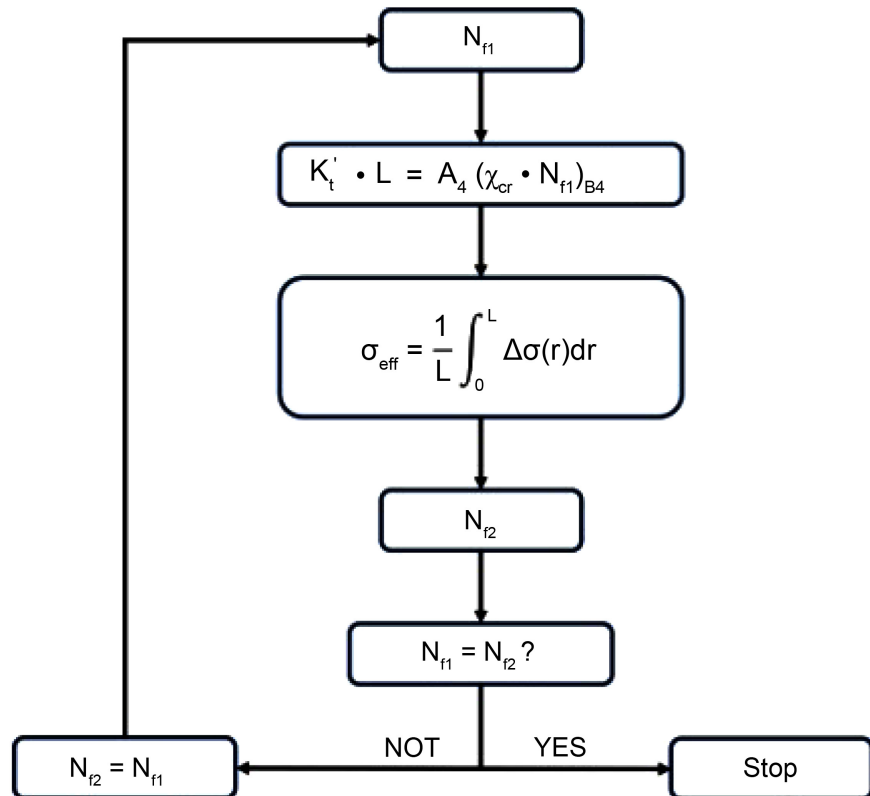

Figure 15. Life prediction process of TCD.

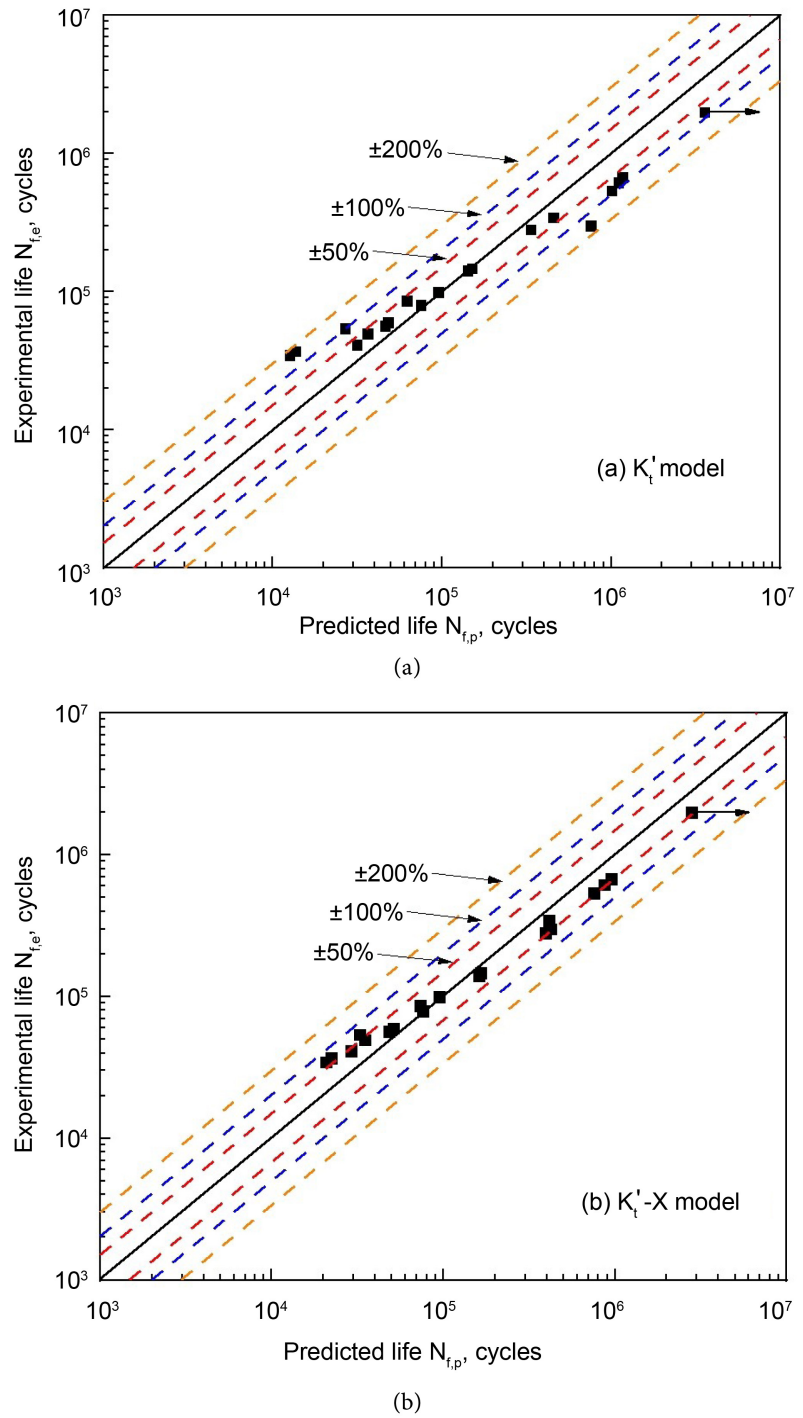

Figure 16. Life prediction results of relief groove structure samples by using (a) K_t' model; (b) K_t' -X model.

5. Conclusions

This article proposes modifications to the TCD and predicts the fatigue life of complex notch structures in experiments. It analyzes the effects of different notch structures on stress distribution and fatigue life. The following conclusions are drawn:

- Although the stress concentration factors are the same, the difference in notch size leads to significantly different stress gradients. Therefore, the influence of the notch root size is mainly reflected in the stress concentration effect, while the change in stress gradient is determined by the overall structure of the notch.
- By incorporating stress concentration factors and stress gradients into the modified fatigue life model based on the critical distance theory, the accuracy of fatigue life prediction is greatly improved, with predicted values within a 100% error band.

Funding

The authors would like to acknowledge Postgraduate Innovation Special Fund Project of Jiangxi Province for funding this work through Project # YC2022-062.

Conflicts of Interest

The authors declare no conflicts of interest regarding the publication of this paper.

References

- [1] Yao, W.X. (1993) Stress Field Intensity Approach for Predicting Fatigue Life. *International Journal of Fatigue*, **15**, 243-246. [https://doi.org/10.1016/0142-1123\(93\)90182-P](https://doi.org/10.1016/0142-1123(93)90182-P)
- [2] Visvanatha, S.K., Straznicky, P.V. and Hewitt, R.L. (2000) Influence of Strain Estimation Methods on Life Predictions using the Local Strain Approach. *International Journal of Fatigue*, **22**, 675-681. [https://doi.org/10.1016/S0142-1123\(00\)00042-6](https://doi.org/10.1016/S0142-1123(00)00042-6)
- [3] Fricke, W. and Paetzoldt, H. (1995) Fatigue Strength Assessment of Scallops—An Example for the Application of Nominal and Local Stress Approaches. *Marine Structures*, **8**, 423-447. [https://doi.org/10.1016/0951-8339\(94\)00029-R](https://doi.org/10.1016/0951-8339(94)00029-R)
- [4] Meggiolaro, M. and Castro, J. (2004) Statistical Evaluation of Strain-Life Fatigue Crack Initiation Predictions. *International Journal of Fatigue*, **26**, 463-476. <https://doi.org/10.1016/j.ijfatigue.2003.10.003>
- [5] Hu, Z., Berto, F., Hong, Y. and Susmel, L. (2019) Comparison of TCD and SED Methods in Fatigue Lifetime Assessment. *International Journal of Fatigue*, **123**, 105-134. <https://doi.org/10.1016/j.ijfatigue.2019.02.009>
- [6] Peterson, R. (1959) Notch Sensitivity. In: Peterson, R., Ed., *Metal Fatigue*, McGraw-Hill, New York, 293-306.
- [7] Neuber, H. (1961) Theory of Stress Concentration for Shear Strained Prismatical Bodies with Arbitrary Nonlinear Stress Strain Law. *Journal of Applied Mechanics*, **28**, 544-550. <https://doi.org/10.1115/1.3641780>
- [8] Taylor, D. (1999) Geometrical Effects in Fatigue: A Unifying Theoretical Model. *International Journal of Fatigue*, **21**, 413-420. [https://doi.org/10.1016/S0142-1123\(99\)00007-9](https://doi.org/10.1016/S0142-1123(99)00007-9)
- [9] Bellett, D., Taylor, D., Marco, S., Mazzeo, E., Guillois, J. and Pircher, T. (2005) The Fatigue Behaviour of Three-dimensional Stress Concentrations. *International Journal of Fatigue*, **27**, 207-221. <https://doi.org/10.1016/j.ijfatigue.2004.07.006>
- [10] Susmel, L. and Taylor, D. (2007) A Novel Formulation of the Theory of Critical

- Distances to Estimate Lifetime of Notched Components in the Medium-Cycle Fatigue Regime. *Fatigue & Fracture of Engineering Materials & Structures*, **30**, 567-581. <https://doi.org/10.1111/j.1460-2695.2007.01122.x>
- [11] Yamashita, Y., Ueda, Y., Kuroki, H. and Shinozaki, M. (2010) Fatigue Life Prediction of Small Notched Ti-6Al-4V Specimens Using Critical Distance. *Engineering Fracture Mechanics*, **77**, 1439-1453. <https://doi.org/10.1016/j.engfracmech.2010.04.001>
- [12] Yu, M.T., DuQuesnay, D.L. and Topper, T.H. (1991) Notched Fatigue Behaviour of Two Cold Rolled Steels. *Fatigue & Fracture of Engineering Materials & Structures*, **14**, 89-101. <https://doi.org/10.1111/j.1460-2695.1991.tb00645.x>
- [13] Meneghetti, G., Ricotta, M. and Atzori, B. (2013) A Synthesis of the Push-Pull Fatigue Behavior of Plain and Notched Stainless Steel Specimens by Using the Specific Heat Loss. *Fatigue & Fracture of Engineering Materials & Structures*, **36**, 1306-1322. <https://doi.org/10.1111/ffe.12071>
- [14] Denk, J., Dallmeier, J., Huber, O. and Saage, H. (2017) The Fatigue Life of Notched Magnesium Sheet Metals with Emphasis on the Effect of Bands of Twinned Grains. *International Journal of Fatigue*, **98**, 212-222. <https://doi.org/10.1016/j.ijfatigue.2017.01.041>
- [15] Sa, M.V.C., Ferreira, J.L.A., da Silva, C.R.M. and Araújo, J.A. (2018) The Role of the Shear and Normal Stress Gradients on Life Estimation of Notched Al7050-T7451 under Multiaxial Loadings. *Theoretical and Applied Fracture Mechanics*, **97**, 38-47. <https://doi.org/10.1016/j.tafmec.2018.07.006>
- [16] Kim, J.K., Kim, D.S. and Takeda, N. (1995) Notched Strength and Fracture Criterion in Fabric Composite Plates Containing a Circular Hole. *Journal of Composite Materials*, **29**, 982-998. <https://doi.org/10.1177/002199839502900706>
- [17] Lanning, D., Nicholas, T. and Palazotto, A. (2005) The Effect of Notch Geometry on Critical Distance High Cycle Fatigue Predictions. *International Journal of Fatigue*, **27**, 1623-1627. <https://doi.org/10.1016/j.ijfatigue.2005.06.017>
- [18] Yang, X., Wang, J. and Liu, J. (2011) High Temperature LCF Life Prediction of Notched DS Ni-Based Superalloy Using Critical Distance Concept. *International Journal of Fatigue*, **33**, 1470-1476. <https://doi.org/10.1016/j.ijfatigue.2011.05.018>
- [19] Mauro, F. (2000) Stress Gradient Calculations at Notches. *International Journal of Fatigue*, **22**, 397-409. [https://doi.org/10.1016/S0142-1123\(00\)00010-4](https://doi.org/10.1016/S0142-1123(00)00010-4)
- [20] Siebel, E. (1955) Ungleichformige Spannung-Sverteilung Bei Schwingender Beanspruchung. *VDiz*, **97**, 121-126.
- [21] Shen, J., Fan, H., Wang, J., *et al.* (2021) A Fatigue Life Evaluation Method for Notched Geometries Considered the Stress Gradient Concept. *International Journal of Fracture*, **234**, 81-96. <https://doi.org/10.1007/s10704-021-00554-7>
- [22] Shen, J., Fan, H., Zhang, G., Pan, R., Wang, J. and Huang, Z. (2022) Influence of the Stress Gradient at the Notch on the Critical Distance and Life Prediction in HCF and VHCF. *International Journal of Fatigue*, **162**, Article ID: 107003. <https://doi.org/10.1016/j.ijfatigue.2022.107003>