

Searching for “Counter Text” as a Way to Solve the Problem

Alexander A. Kharlamov^{1,2,3,4} 

¹Laboratory of Neuroontogenesis, Institute of Higher Nervous Activity and Neurophysiology of RAS, Moscow, Russia

²Department of Intellectual Informational Systems and Technologies of Moscow Institute of Physics and Technology, Moscow, Russia

³Department of Program Engineering of Higher School of Economics University, Moscow, Russia

⁴Department of Applied and Experimental Linguistics, Moscow State Linguistic University, Moscow, Russia

Email: kharlamov@analyst.ru

How to cite this paper: Kharlamov, A. A. (2025). Searching for “Counter Text” as a Way to Solve the Problem. *Sociology Mind*, 15, 185-198.

<https://doi.org/10.4236/sm.2025.153011>

Received: June 3, 2025

Accepted: July 27, 2025

Published: July 30, 2025

Copyright © 2025 by author(s) and Scientific Research Publishing Inc. This work is licensed under the Creative Commons Attribution International License (CC BY 4.0).

<http://creativecommons.org/licenses/by/4.0/>



Open Access

Abstract

Problem solving is an example of purposeful behavior that boils down to searching for a description of a chain of situations that lead to a target situation from the current situation in internal or external sources, or to synthesize such a chain if it is not found in the annals. To do this, we need to find a (counter) text, the semantic network of which includes both the current situation and the target situation (and so that these two situations are related to each other in the semantic network of this text), and then the semantic network of this (counter) text bridges (closes the “gap” between) the two original situations—the current situation and the target one, thereby offering the solution to the original problem. Algorithmically searching for counter text comes down to the formation of semantic networks of candidate texts, which contain chains of nodes, including nodes that in the subsequent projection onto the hippocampal situation models, and then onto the anterior cortex, can be considered as those establishing the connection between the current and target situations. For using the TextAnalyst technology, we can solve the problem of constructing a homogeneous directed weighted semantic network where the desired chain can be found.

Keywords

Purposeful Behavior, Chain of Situations, Current Situation, Target Situation, Homogeneous Directed Weighted Semantic Network, TextAnalyst Technology

1. Introduction

The purpose of the work is to solve the problem “Solving the problem”. Problem

solving is an example of purposeful behavior that boils down to searching for a description of a chain of situations that lead to a target situation from the current situation in internal or external sources, or to synthesizing such a chain if it is not found in the annals.

Searching for a description of a chain of situations to achieve the target situation from the current situation is an urgent task (see for example, “ORGANIZING AND CONDUCTING PR CAMPAIGNS IN THE FIELD OF PUBLIC RELATIONS” <https://studfile.net/preview/9349408/>).

There are currently no automatic (algorithmic) solutions to identify a chain of situations (Kotseruba & Tsotsos, 2020). Existing cognitive architectures implement particular (automatic) algorithms at all language levels, from morphological analysis to semantic analysis of single sentences of a text—see (Kotseruba & Tsotsos, 2020 Section 11.2.5). Texts in their entirety are not automatically analyzed from the point of view of semantics now. The author has proposed an algorithm (implemented in TextAnalyst technology (Kharlamov, 2025)) for the automatic construction of the semantic network of the whole text as a set of semantic networks of individual sentences of the text, where semantic repetitions are excluded from the aggregate network.

In the current work, we proposed an algorithm for finding a chain of situations from the “counter text” that closes the missing part of the chain from the current situation to the target situation. The algorithm for the automatic construction of the semantic network of an individual text and the text corpus, implemented in TextAnalyst, where individual situations (the scene of the beginning of the situation, the scene of the continuation of the situation, the scene of the end of the situation) are represented by chains of sentences of the text, can be used to identify this missing link.

As an example of solving the problem, let’s consider the harvest in the traditional Russian fairy tale “Turnip”. The full text of the fairy tale is given below.

The Turnip’s Tale (original) Grandfather planted a turnip. A big, big turnip has grown. Grandpa went to pick a turnip: he pulled and pulled, he couldn’t pull it out! The grandfather called the grandmother: the grandmother for the grandfather, the grandfather for the turnip—they pulled and pulled, they could not pull it out! The grandmother called her granddaughter: the granddaughter for the grandmother, the grandmother for the grandfather, the grandfather for the turnip—they pulled and pulled, they could not pull it out! The granddaughter called Zhuchka: Bug for granddaughter, granddaughter for grandmother, grandmother for grandfather, grandfather for turnip—they pull and pull, they can’t pull it out! The Bug called the cat: the cat for the Bug, the Bug for the granddaughter, the granddaughter for the grandmother, the grandmother for the grandfather, the grandfather for the turnip—they pull and pull, they can’t pull it out! The cat called the mouse: the mouse for the cat, the cat for the Bug, the Bug for the granddaughter, the granddaughter for the grandmother, the grandmother for the grandfather, the grandfather for the turnip—pull, pull, pull—pull the turnip!

In a fairy tale, the goal situation is achieved: “pulled the turnip” out of the current situation: “pull-pull”. As a source text, let’s take the first part of the fairy tale: “Grandfather planted a turnip. A big, big turnip has grown. Grandpa went to pick a turnip: he pulled and pulled, he couldn’t pull it out! The grandfather called the grandmother: the grandmother for the grandfather, the grandfather for the turnip—they pulled and pulled, they could not pull it out! The grandmother called her granddaughter: the granddaughter for the grandmother, the grandmother for the grandfather, the grandfather for the turnip—they pulled and pulled, they could not pull it out! The granddaughter called Zhuchka: Bug for granddaughter, granddaughter for grandmother, grandmother for grandfather, grandfather for turnip—they pull and pull, they can’t pull it out! The Beetle called the cat: the cat for the Beetle, the Bug for the granddaughter, the granddaughter for the grandmother, the grandmother for the grandfather, the grandfather for the turnip—they pull and pull, they can’t pull it out!”

The counter text will be the rest of the text: “The cat called the mouse: the mouse for the cat, the cat for the Beetle, the Beetle for the granddaughter, the granddaughter for the grandmother, the grandmother for the grandfather, the grandfather for the turnip—pull, pulled the turnip!”

Empirical evidence to support the findings of the study is currently lacking, as neuroscience research is currently more or less confident only in the first (or last) stages of processing specific (e.g., language—(Khanna, Muñoz, Kim, Kfir, Paulk, Jamali et al., 2024)) information in the brain. More complex stages of processing (for example, semantic (Jamali, Grannan, Cai, Khanna, Muñoz, Caprara et al., 2024)) encounter significant ambiguity in information processing in the brains of different individuals, depending on different psychological types of individuals, and different traces of information processing in the brains of different people.

Let’s consider the search for a description of a chain of situations for achieving the target situation from the current situation. Let us consider in more detail the formulation of the problem when the desired solution is sought in the form of a text obtained from internal or external sources that describes the problem being solved. The statement of the problem solving using solutions already available in external sources was common already fifty years ago, when the first information retrieval systems were created (Leontyeva, 2006). Theoretically, the solution was narrowed down to searching for the so-called “counter text” (the concept “counter text” was introduced by N.N. Leontyeva (Leontyeva, 2006)).

Definition. Given a current situation and a target situation, a text that contains a chain of situations that ensures the transition from the current situation to the target situation is called a counter text.

It should be noted that counter text can be considered both a language text and a quasi-text of a quasi-language.

Problem statement. Let us formally consider the statement of the problem of finding a counter text: we need to find a text that contains a chain of situations leading from the current situation to the target one and describing the solution to

the problem. For that end, we try using a directed homogeneous semantic network of the so-called “counter” text (Kharlamov, 2023a). To do this, we need to find a (counter) text, the semantic network of which includes both the current situation and the target situation (and so that these two situations are related to each other in the semantic network of this text), and then the semantic network of this (counter) text bridges (closes the “gap” between) the two original situations—the current situation and the target one, thereby offering the solution to the original problem.

This statement of the problem can be extended to the case of quasi-texts, when the current and target situations are described not in terms of the language text, but in terms of the representation of these situations in extra-linguistic (multi-modal—extralinguistic) reality—in terms of the quasi-text (for example, in terms of a video sequence). Any non-linguistic (extralinguistic) quasi-text can also be considered as the initial structure for forming a semantic network (Kharlamov, 2017). And then the term “text” is replaced with the term “quasi-text” in the previous steps, while the problem-solving process proceeds analogously.

Let us formally describe the process of searching for a chain to the target situation from the current one in the semantic network of the counter text. We formalize this representation in terms of homogeneous directed weighted semantic networks (Kharlamov, 2023a).

2. Purposeful Behavior as a Way to Solve a Problem

2.1. Planning Purposeful Behavior

The search for a chain of situations from the current situation to the target one is the result of planning purposeful behavior. Planning purposeful behavior is a procedure for choosing a path (chain of events) on the hierarchy of representations of motor actions, which is realized in the anterior (motor) cortex of the human brain, where a hierarchy of levels of dictionaries is represented that reflect varying degrees of generality of fragments of motor behavior. This chain is constructed by fitting (for example, by means of fuzzy logic (Borisov & Kharlamov, 2023)) a chain of situations, from the current situation to the target one \hat{I}_1 and \hat{I}_{fin} (which is selected in the hierarchy of representations of the motor—*i.e.* anterior-cortex), by projecting into the representation of situations on the world model presented in the lamellae of the hippocampus (Kharlamov, 2023a) from the template of the current situation to the template of the target situation S_1 and S_{fin} ; and then projecting the representation of the combinatorics of objects and events (represented within the templates of situations in the hippocampal world model) into the world model of the sensory cortex, represented in the columns of the sensory cortex containing representations of the objects and events themselves (Kharlamov, 2023a) \hat{S}_1 and \hat{S}_{fin} , see **Figure 1(A)**. The cap above the symbol indicates the so called trajectory in the multidimensional space modeled by the cortex column (see formula (1) in Section 2.1) in which the dictionary is formed.

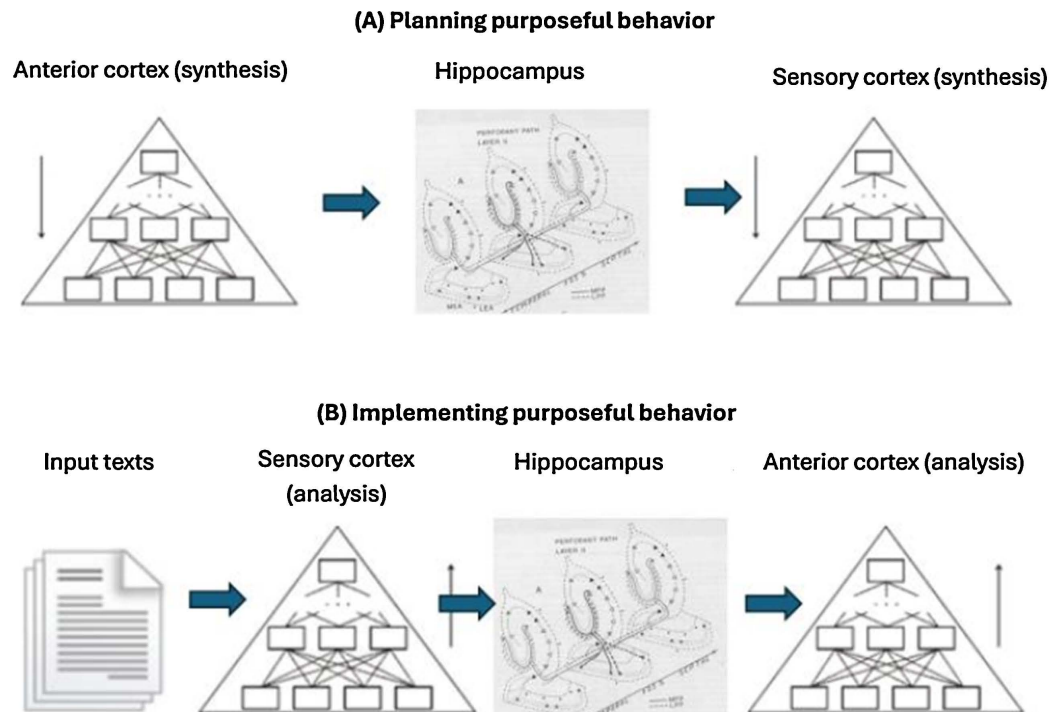

Figure 1. (A) Planning purposeful behavior. Identification of a pair of events \hat{I}_1 and \hat{I}_{fin} represented on the world model formed in the anterior (motor) cortex, which is projected onto the templates of situations S_1 and S_{fin} in the hippocampus and then onto the images of events and objects \hat{S}_1 and \hat{S}_{fin} , represented in the columns of the sensory (posterior) cortex. (B) Implementing purposeful behavior. Search for a “counter” text containing the current and target situations \hat{S}_1 and \hat{S}_{fin} , projection of this text onto the templates of situations S_1 and S_{fin} stored in one or more lamellae of the hippocampus, and then projection of these situations into the anterior cortex, where it is assumed that, with the help of this chain of situations, the pair of initial events \hat{I}_1 and \hat{I}_{fin} will be bridged.

2.2. Implementing Purposeful Behavior

This purposeful behavior (see **Figure 1(B)**) is implemented in the reverse order: searching for a counter text, followed by identifying, within the semantic network of this text, a chain of situations from the current situation to the target one \hat{S}_1 and \hat{S}_{fin} , respectively, identifying a chain of suitable templates of situations S_1 and S_{fin} from the current situation to the target one in the lamellae of the hippocampus, and finally—identifying appropriate actions in the hierarchy of the anterior (motor) cortex bridge the original pair of events \hat{I}_1 and \hat{I}_{fin} , which originated all these processes.

A set of pairs of word root stems (since we are considering the example of the language part of the world model), presented in the dictionaries (see **Figure 2**) of the upper (semantic) level of the hierarchy of representations in the columns of the sensory cortex, which is obtained during the processing of a particular text, that is, a semantic network (homogeneous, directed, with weighted vertices and connections (Kharlamov, 2023a)) is virtually united into a semantic network of the t -th text, \hat{M}_t . On this semantic network, the desired pair of situations is

sought: \hat{S}_1 and \hat{S}_{fin} . This pair in the lamellae of the hippocampus corresponds to a pair of situations S_1 and S_{fin} , which are the beginning and end of the desired chain of situations. Next, in the anterior cortex, the names of \hat{I}_1 and \hat{I}_{fin} are sought, corresponding to the beginning and target of this chain of situations.

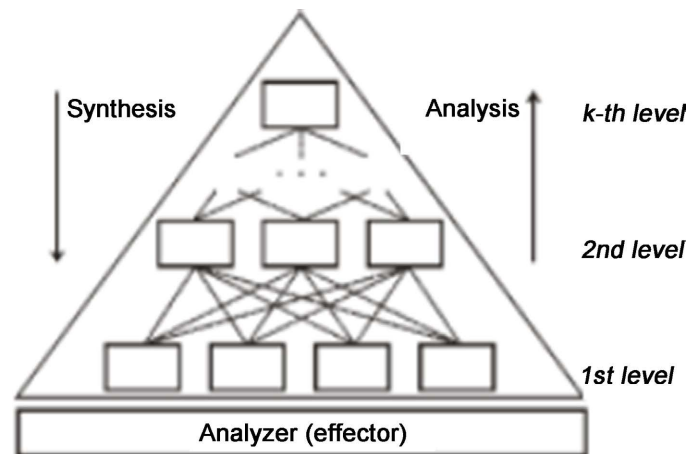

Figure 2. Hierarchy of dictionaries of level-forming elements of various levels of various modalities, in the case of a language hierarchy from the phonemes level to the level of pairwise compatibility of word root stems in the text—premissible compatibility (semantics).

The code sequence corresponding to the analyzed text forms a dictionary $\{B_i\}_1$ of the most frequently repeated fragments of the sounding text at the first level in the cortex, that is, phonemes.

At the next level of processing (let us call it morphological), a dictionary of the morphological level $\{B_j\}_2$ is formed that characterizes the most frequently encountered units of the text, that is, inflectional morphemes. At the next (lexical) level, dictionaries of word root stems $\{B_k\}_3$ are presented. The syntactic level presents a dictionary of syntaxemes, which are an inflectional structure of successive pairs of words of the text with cuts instead of word stems $\{B_l\}_4$. Here, when forming syntactic sequences, at the input of the word stem level, elements of the morphological level are filtered from the input texts that connect word stems into more complex images—pairs of root stems for successive pairs of words in the text. At the output of this level, only a sequence of pairwise combined root stems of words $\{B_m\}_5$ remains in the so called “syntactic” sequence—a sequence of connections of filtered elements of the bottom level (see formulae (3) of section 3.1).

Weighing of nodes is a separate procedure, see formula (6), which takes into account the depth of connections of individual nodes on this semantic network – see section 4.2.

Thus, one can talk about multi-level structural processing of information in the columns of the cortex.

Similar to the hierarchy of dictionaries of level-forming elements of language, one can consider hierarchies of level-forming elements of quasi-language, for example, in the visual modality. The top level of this hierarchy corresponds to the

semantic network of the extralinguistic world model, and these two semantic networks (linguistic and extralinguistic) represent the world in the same way (at least in their core part), that is, their core parts are isomorphic (“mapped one-to-one and onto”).

From these chains, a chain is selected that optimally matches the individual’s world model.

2.3. Formation of a Counter Quasi-Text as a Result of Purposeful Behavior

We have considered purposeful behavior in the context of searching for “counter text”. However, such a counter text may not necessarily be a language text: the counter text sought may also be a quasi-text in an extralinguistic representation. In this case, the order of planning and implementing purposeful behavior is completely preserved, however, quasi-texts of the corresponding modalities are used instead of texts; in the hippocampus, the processes occur in both hippocampal dominant and subdominant parts; and in both the sensory and anterior cortex, the model is presented in both the dominant and subdominant hemispheres, since in fact, with the exception of special cases, purposeful behavior is always mixed (with the participation of linguistic and extralinguistic representations in both the cortex and the hippocampus).

3. Text Analysis as the Formation of a Chain of Situations—A Procedure for Solving a Problem

Then the solution to the original problem can be approached as a search for a chain of situations from the current situation \hat{S}_1 to the target situation \hat{S}_{fin} , which represents a solution to this original problem. Let us consider the procedure for planning purposeful behavior using the example of selecting a text describing purposeful behavior to solve the original problem of achieving the target situation from the current one. This procedure boils down to searching for a text where this chain of situations already exists. In this case, it is not important where this text is located, in the internal base or in the external one.

3.1. Constructing a Semantic Network of Text

The text search procedure is reduced to searching for a text that contains the desired chain. The search for such a text can be shown on the example of forming a semantic network of text in the TextAnalyst program (Kharlamov, 2023b; Kharlamov, 2025). The TextAnalyst program solves the problem of constructing a homogeneous directed weighted semantic network where the desired chain can be found. Constructing a semantic network of text involves implementing several steps:

- 1) Removal of non-textual information from the text.
- 2) Removal of redundant information from the text.
- 3) Splitting the text into tokens and sentences.

- 4) Counting the frequency of occurrence for tokens and token pairs.
- 5) Developing a primary network.
- 6) Calculating the semantic ranks of network nodes.

Removal of non-textual information from the text. It is necessary to remove information that is not involved in the formation of the semantic network: this means removal of non-textual information, that is, pictures, diagrams; replacing numbers with words; decoding abbreviations and acronyms.

Removal of redundant information from the text. Pronouns, prepositions and articles are removed from the text. Since a homogeneous semantic network is constructed based on the text, verbs are no longer in demand as all relations in the representations of text sentences are replaced by an associative type of connection (to be close to each other in the text).

Splitting the text into tokens and sentences. Since it is necessary to identify individual units of text when constructing a network, it is split into tokens. To identify the degree of coherence of words included in the text, it is split into pairs of words within individual sentences.

Counting the frequency of occurrence for tokens and token pairs. To further calculate the ranks of network nodes and the values of the weights of word connections in the network, the frequency of occurrence for tokens and token pairs is counted in the primary network.

Forming a primary network. From the remaining (not removed during pre-processing) words of the text, a primary directed homogeneous semantic network is constructed, the nodes of which and the connections between the nodes are weighted by the calculated frequencies of occurrence.

Calculating the semantic ranks of network nodes. Finally, the weight characteristics of words are replaced by semantic ranks: the weight characteristics of network nodes are recalculated. Those nodes that are connected in the network with a large number of nodes with a large weight increase their weight to the detriment of the weights of other nodes, see formula (6).

3.2. Identifying a Chain of Situations—A Plan of Purposeful Behavior

This procedure is implemented for all candidate texts. As a result, in the obtained semantic networks of texts, chains of nodes are identified from the node describing the current situation \hat{S}_1 to the node describing the target situation \hat{S}_{fm} . Of these texts, one is selected where the obtained chain is more effective than the others: shorter, having a greater weight, or selected according to some other criteria.

Since both the counter text and the counter quasi-text are structures that allow solving the problem (as in this case both the text and the quasi-text are transformed into semantic networks (Kharlamov, 2017), in one case linguistic, in the other case extralinguistic, which both describe the world in which a person lives), it turns out to be insignificant in which modality the problem is solved. In the

human world model, both linguistic and non-linguistic descriptions of the world are presented in the form of semantic networks. These descriptions are isomorphic: what is in one description is also in the other. Therefore, the problem posed can be solved in any of the modalities by obtaining a text (quasi-text) that forms a chain of situations from the current situation to the target one. Therefore, we can further consider the solution to the problem on the example of using the language text.

A counter text of a natural language (quasi-text) can be searched for in three ways. 1) Search in the internal database of texts (quasi-texts), which are available as a result of accumulated life experience. 2) Search in the external database of texts (quasi-texts). 3) Formation of such a text (quasi-text), if there is no suitable text in either the internal or external databases.

The search procedure includes (Kharlamov, 2023b) comparison of texts, classification of texts and selection of relevant texts. Formation of a counter text not available in the internal and external databases turns out to be a significantly more complex procedure, since it is associated with the generation of texts describing the solution of problems in specific subject domains. Formation of such behavior is an example of creative behavior and is beyond the scope of this work. Moreover, at the present, neither an implementation, nor even a description of this procedure exists (at least for artificial systems).

As a historical anecdote, the generation of a counter-text for solving a specific problem can be illustrated by Isaac Newton's formulation of the law of universal gravitation. The story of Newton sitting under an apple tree heavy with ripe fruits and being struck by a falling apple represents a counter-quasi-text that allowed him to bridge the gap and complete the solution to the problem of formulating his famous law.

4. Related Works. World Model as a Basis for the Implementation of Purposeful Behavior

Algorithmically, the sensory level of searching for counter text comes down to the formation of semantic networks of candidate texts, which contain chains of nodes, including nodes that in the subsequent projection onto the hippocampal situation models, and then onto the anterior cortex, can be considered as those establishing the connection between the current and target situations.

Let us consider the processes of planning and implementing purposeful behavior in more detail: how the semantic network of text is formed in the sensory cortex; what happens in the lamellae of the hippocampus when selecting situation templates; and how all this interacts with representations in the anterior cortex. After this, we need to reconsider the same processes again, but already in the context of searching for counter quasi-text.

4.1. Human World Model. Sensory Level

The sensory level of purposeful behavior is based on the world model presented

in the sensory cortex. The world model in the sensory cortex is formed as a set of hierarchies of dictionaries of various modalities (see **Figure 2**), which at the top level of the hierarchies are combined into two semantic networks – linguistic and extralinguistic (Kharlamov, 2023b).

Let us demonstrate this, as usually, on the example of linguistic behavior, which is currently formalized within the subject domain of “Linguistics” quite well (Kharlamov, 2023b). The language world model is a hierarchy of dictionaries of level-forming elements of language (see **Figure 2**) from phonemes (for sounding text) to the level of permissible pairwise compatibility of dictionary words (semantic level), which can be represented by a directed weighted semantic network.

The hierarchy of level representations is formed as a result of the structural analysis of input sensory sequences $\{A\}$ (Kharlamov, 2023b). In this case, the input code sensory sequences are displayed (see formula (1)) in the columns of the cortex by pyramidal neurons of the 3rd layer of the cortex as neurons with temporal summation of signals in trajectories in a multidimensional space, which (trajectories) are repeatedly traversed in the presence of repeating fragments in the input text, thereby forming dictionaries (see formula (2)) of these level-forming elements in the learning process.

Let $\{A\}$ denote the set of code sequences formed by the signal periphery of analyzers, the elements of which are the symbols that make up the codes of the input sequences $A = (\dots, a_{-1}, a_0, a_1, \dots, a_i, \dots)$. Hereinafter, for simplicity, we will consider everything on the example of processing binary sequences. In the binary case, $a_i \in \{0, 1\}$. As such a sequence, we can, for example, take the read over text of L. N. Tolstoy’s novel “War and Peace”, encoded with a binary code.

Let $\{\hat{A}\}$ denote the set of trajectories of sequences corresponding to the set of input sequences $\{A\}$, the elements of which \hat{a}_i are points of the space R^n , i.e. nodes of the unit hypercube $\hat{a}_i \in G_e^n$, where $\hat{a}_i = (a_{i-n+1}, a_{i-n+2}, \dots, a_i)$ are successive fragments of length n of sequence A symbols, shifted relative to each other by one symbol (by one time unit) – coordinates of points in the multidimensional space R^n (due to the binarity of the representation – nodes of the unit hypercube G_e^n). Then:

$$F_n : A \rightarrow \hat{A}, F_n(A) = \hat{A}, \quad (1)$$

where $A = (\dots, a_i, \dots : a_i \in \{0, 1\})$, a

$$\begin{aligned} \hat{A} &= (\dots, \hat{a}_{-2}, \hat{a}_{-1}, \dots, \hat{a}_i, \dots) \\ &= (\dots, (a_{-n-1}, a_{-n}, \dots, a_{-2}), (a_{-n}, a_{-n+1}, \dots, a_{-1}), \dots, (a_{i-n+1}, a_{i-n+2}, \dots, a_i), \dots). \end{aligned}$$

The dictionary as a set of repetitions of fragments of input sensory sequences is formed from a set of sequences $\{A\}_k$, in each of which, using the transformation $H_h RMF_n$ (mapping sequences of class $\{A\}_k$ into an n -dimensional space and applying a threshold transformation to them), subsequences $B_j \subset A_k$ included in it at least h times are selected. Thus, the transformation $H_h RMF_n$ when interacting with the input set $\{A\}_{k_1}$ in the space of a given dimension restores the dictionary $\{\hat{B}\}_{k_1}$ of subsequences B_i included in the trajectories of the input

set:

$$\{\hat{B}_i\}_{k_i} = H_h R M F_n \left(\{A\}_{k_i} \right). \tag{2}$$

The resultant dictionary functions as a filter, identifying the connections of words of the lower level dictionary within the input code sequences (3).

$$F_{n,C}^{-1} \left(\tilde{A}, \{\hat{B}_j\} \right) = C, \tag{3}$$

where $C = \left(\tilde{a}_i \mid \hat{a}_i \neq \hat{b}_j \quad 0 \mid \hat{a}_i = \hat{b}_j \right)^T$, here, $\tilde{a}_i \in \hat{A}$ и $\hat{a}_i \in \hat{A}$, а $\tilde{b}_j \in \hat{B}$ и $\hat{b}_j \in \hat{B}$.

The so-called “syntactic” sequences obtained as a result of filtering form the dictionary of the next level (see **Figure 3**).

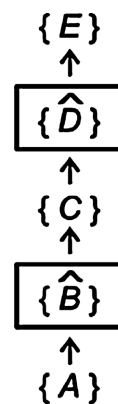

Figure 3. Standard element of a multi-level hierarchical structure.

All of this taken together can be represented as a hierarchy of dictionaries of level-forming elements of language of various levels of complexity (see **Figure 2**).

4.2. World Model. Hippocampus Level

The world model in terms of level-forming elements represented in the columns of the sensory cortex represents the modeled world virtually (see **Figure 2**): pairs of root stems of the top-level words of the language model and pairs of images of objects and events of the top-level extralinguistic model are combined into language and extralinguistic networks, which are essentially semantic: pairs of events of the extralinguistic network characterize the permissible compatibility of objects and events of the modeled world, as do pairs of root stems of the language network that describe them. These objects and events (and the root stems that describe them) are used to form models of the next stratum of representations formed and stored in the lamellae of the hippocampus as combinations of images of these objects and events (and, in the dominant hippocampus, of words that describe them). These hippocampal models are models of scene templates (sequences of scenes—beginning-continuation-end—describe complete situations).

$$\hat{F} = *S\hat{f}_p = \hat{f}_1 * (*S\hat{f}_p) = \hat{I} * (*S\hat{f}_p), \tag{4}$$

where \widehat{Sf}_p can be conventionally referred to as a subframe, where \hat{I} is the name of the frame (e.g., a word in one of the modalities). The subframe \widehat{Sf} can be represented as a union of the frame components, where $[*]_i$ is the concatenation by sequential index i :

$$\begin{aligned} \widehat{Sf} &= \bigcup_m (\hat{f}_m) = \bigcup_m (*\hat{A}_{ijKm} \vee_{ijk < K} \hat{A}_{ijkm}) \\ &= \bigcup_m (*\hat{A}_{ijKm} \vee_{ijk < K} \hat{A}_{ijkm}) = \hat{f}_1 \cup (\bigcup_{m \neq 1} \hat{f}_m), \end{aligned} \tag{5}$$

\hat{f}_m is a frame component: $\hat{f}_m = \hat{A}_{ijKm} \vee \hat{A}_{ijkm}$, where \hat{A}_{ijkm} are chains on the graph, and \vee represents inclusion in its place into the words of a higher level dictionary.

According to biologists (Rolls, 1990), these models represent the contents of the memory of the CA₃ fields of the hippocampal lamellae, which are modeled by Hopfield artificial neural networks (Figure 4): with each lamella representing a separate situation.

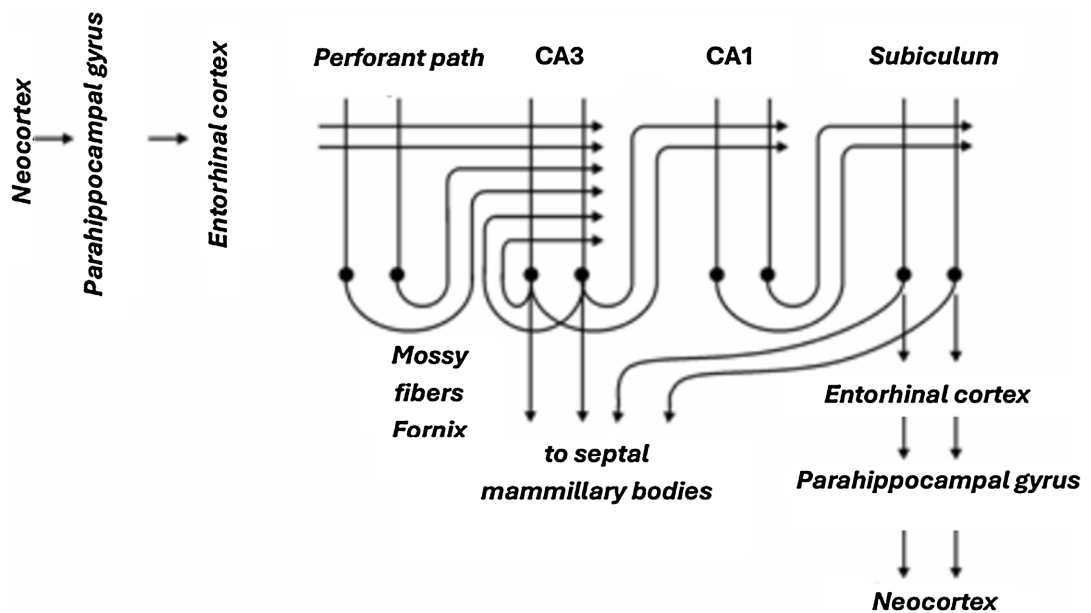

Figure 4. Architecture of the hippocampus according to Rolls (Rolls, 1990).

The scene model stored in the associative memory of the Hopfield network of the hippocampal lamella represents a combinatorics of images of events and objects that are part of the situation (more precisely, indices of their representations in the columns of the sensory cortex (Bekhtereva, 1978)), as well as phrases of the language that describe them (where words are also represented as indices of their storage in the columns of the sensory cortex, where their images are presented in detail) (Kharlamov, 2023b).

Individual fragments of the associative memory of the hippocampus, represented in individual lamellae, are a unified world model in the form of a total associative network, where individual events are dependent on other events they are connected with in this associative network, and therefore their ranks in the

model are calculated iteratively—see formula (6)—taking into account these connections in the process of iterative access to storage (up to 20 cycles) (Vinogradova, 1975).

The initially formed statistical representation of the text (a network of event images with their connections as the frequency of occurrence of events and connections between them) undergoes re-ranking, thus allowing move from a frequency portrait of the text to an associative network of key images of text events (networks with ranks of these events, that is, their semantic weights):

$$w_i(t+1) = \left(\sum_j w_j(t) w_{ij} \right) \sigma(\bar{E}), \quad (6)$$

where $w_i(0) = z_i$; $w_{ij} = z_{ij} / z_j$ and $\sigma(\bar{E}) = 1 / (1 + e^{-k\bar{E}})$ is a function normalizing to the average energy value of all network nodes \bar{E} ; z_i is the frequency of occurrence of the i -th word in the text, z_{ij} is the frequency of co-occurrence of the i -th and j -th words in text fragments; t is the iteration number. The resulting numerical characteristic of words (their semantic weight) characterizes the degree of their significance in the text.

4.3. World Model. Anterior Cortex Level

There is also a third stratum of representation of the world model in the human brain (see **Figure 1(B)**). It is represented in the anterior cortex, where this model is represented (at the lowest level in the hierarchy of representations) in the form of motor activity control, and at higher levels—in the form of fragments of generalized behavior plans of varying degrees of generalization. At the highest level of representation in this hierarchy, this stratum is represented in the form of images of ideas of behavioral activity in generalized situations. These generalized representations at lower levels unfold into increasingly detailed behavioral acts, and at the lowest level—into acts of motor control. For example, articulatory—in the case of using motor function when producing voiced speech.

5. Conclusion

Thus, as a result of purposeful behavior involved in the problem-solving task, that is, searching for a chain of situations that bridges the current and target situations in the internal or external databases, the so-called “counter” text is searched for, the semantic network of which contains a chain from the current situation to the target one, which resolves the problem-solving task.

When there is no immediately available counter text, or this text is non-existent at all at the current moment, it becomes necessary to synthesize a text that serves as a counter text for solving the problem. And then this synthesized text constitutes a discovery. In this paper, the issue of synthesizing the desired counter text is not addressed: the problem of synthesis of purposeful behavior has not yet been solved as any “texts” synthesized by GPT-like systems are texts synthesized by a chain of reference semantic points predefined externally. That is, such systems, in essence, do not differ from speech synthesis systems from text, where the source

text is predefined externally.

This approach can be used for specific AI applications, such as robotics or decision support systems. To do this, it is necessary to improve the TextAnalyst technology, for example, in the direction of analyzing video sequences.

Conflicts of Interest

The author declares no conflicts of interest regarding the publication of this paper.

References

- Bekhtereva, N. P. (1978). *Brain Codes of Psychic Activity [Mozgovye kody psikhicheskoy aktivnosti]*. Nauka. (In Russian)
- Borisov, V., & Kharlamov, A. A. (2023). Intelligent Analysis and Scenario Modeling of Problem Situations Based on a Combination of Neural Network Technology for Text Processing, Dynamic Clustering Methods and Fuzzy Cognitive Analysis. In A. A. Kharlamov, & M. Pilgun (Eds.), *Integral Robot Technologies and Speech Behavior* (pp. 51-87). Cambridge Scholars Publishing.
- Jamali, M., Grannan, Be., Cai, J., Khanna, A. R., Muñoz, W., Caprara, I., Paulk, A. C., Cash, S. S., Fedorenko, E., & Williams, Z. M. (2024). Semantic Encoding during Language Comprehension at Single-Cell Resolution. *Nature*, *631*, 610-616. <https://doi.org/10.1038/s41586-024-07643-2>
- Khanna, A. R., Muñoz, W., Kim, Y. J., Kfir, Y., Paulk, A. C., Jamali, M., Cai, J., Mustroph, M. L., Caprara, I., Hardstone, R., Mejdell, M., Meszéna, D., Zuckerman, A., Schweitzer, J., Cash, S., & Williams, Z. M. (2024). Single-Neuronal Elements of Speech Production in Humans. *Nature*, *626*, 603-610. <https://doi.org/10.1038/s41586-023-06982-w>
- Kharlamov, A. A. (2017). *Associative Memory as an Environment for the Formation of a Space of Knowledge. From Biology to Applications [Assotsiativnaya pamyat' sreda dlya formirovaniya prostranstva znaniy. Ot biologii k prilozheniyam]*. Palmarium Academic Publishing. (In Russian)
- Kharlamov, A. A. (2023a). Speech as Purposeful Behavior. *Integral Robot Technologies and Speech Behavior*. In A. A. Kharlamov, & M. Pilgun (Eds.), *Integral Robot Technologies and Speech Behavior* (pp. 1-50). Cambridge Scholars Publishing.
- Kharlamov, A. A. (2023b). Text and Quasi-Text Analysis: Upper Levels of Speech Information Processing. In A. A. Kharlamov, & M. Pilgun (Eds.), *Integral Robot Technologies and Speech Behavior* (pp. 88-129). Cambridge Scholars Publishing.
- Kharlamov, A. A. (2025). *Text Analyst*. <https://analyst.ru/en/about>
- Kotseruba, I., & Tsotsos, J. K. (2020). 40 Years of Cognitive Architectures: Core Cognitive Abilities and Practical Applications. *Artificial Intelligence Review*, *53*, 17-94. <https://doi.org/10.1007/s10462-018-9646-y>
- Leontyeva, N. N. (2006). *Automatic Text Understanding. Systems, Models, Resources [Avtomaticheskoe ponimanie tekstov. Sistemy, modeli, resursy]*. Academia. (In Russian)
- Rolls, E. T. (1990). Theoretical and Neurophysiological Analysis of the Functions of the Primate Hippocampus in Memory. *Cold Spring Harbor Symposia on Quantitative Biology*, *55*, 995-1006. <https://doi.org/10.1101/SQB.1990.055.01.095>
- Vinogradova, O. S. (1975). *Hippocampus and Memory [Gippokamp i pamyat]*. Nauka. (In Russian)