

# Potential for Green Hydrogen Production in Burkina Faso from a Photovoltaic Power Plant: An Estimation Approach

Serge Dimitri Bazyomo<sup>1,2</sup>, Stanislas Sanfo<sup>3,4</sup>, Lamboni Batablinle<sup>5</sup>, Celestin Manirakiza<sup>6</sup>, Abdoulaye Ouedraogo<sup>4</sup>, Emmanuel Lawin<sup>7</sup>

<sup>1</sup>Renewable Thermal Energy Laboratory, University Joseph KI-ZERBO, Ouagadougou, Burkina Faso

<sup>2</sup>Department of General Biology Daniel OUEZZIN COULIBALY University, Dédougou, Burkina Faso

<sup>3</sup>Department of Physics, Lédéa Bernard OUEDRAOGO University, Ouahigouya, Burkina Faso

<sup>4</sup>Laboratory of Physics and Chemistry of the Environment, University Joseph KI-ZERBO, Ouagadougou, Burkina Faso

<sup>5</sup>Laboratory of Solar Energy, University of Lomé, Lomé, Togo

<sup>6</sup>Department of Natural Sciences, Ecole Normale Supérieure of Burundi, Bujumbura, Burundi

<sup>7</sup>Laboratory of Applied Hydrology, National Institute of Water, University of Abomey-Calavi, Calavi, Benin

Email: sbazyomo@gmail.com

**How to cite this paper:** Bazyomo, S.D., Sanfo, S., Batablinle, L., Manirakiza, C., Ouedraogo, A. and Lawin, E. (2025) Potential for Green Hydrogen Production in Burkina Faso from a Photovoltaic Power Plant: An Estimation Approach. *Smart Grid and Renewable Energy*, **16**, 203-217. <https://doi.org/10.4236/sgre.2025.1611012>

**Received:** October 6, 2025

**Accepted:** November 22, 2025

**Published:** November 25, 2025

Copyright © 2025 by author(s) and Scientific Research Publishing Inc. This work is licensed under the Creative Commons Attribution International License (CC BY 4.0).

<http://creativecommons.org/licenses/by/4.0/>



Open Access

## Abstract

In the context of decarbonization with the goal of minimizing temperature rise, the production of hydrogen from photovoltaic (PV) has piqued interest due to its potential as an energy vector. This research investigates the possible production of green energy utilizing fixed photovoltaic-based hydrogen direct arrangements. Furthermore, the study investigates the potential amounts of fossil fuel (petrol) and greenhouse gas emissions that can be avoided. Our solar PV technology is based on crystalline silicon panels with 17% efficiency. Regarding the possibility of electrification, GH<sub>2</sub> energy production reaches 720 MWh.year<sup>-1</sup>. A total of 136252.7 L per year might be replaced with this possible amount of GH<sub>2</sub> across the country. The results for greenhouse gas emissions reveal that 313.38 tons and 562.71 kg, respectively, of CO<sub>2</sub> and CO, might be prevented every year.

## Keywords

Decarbonization, Photovoltaic-Based Hydrogen, Green Hydrogen Potential, Re-Electrification

## 1. Introduction

Like several countries, Burkina Faso is implementing different measures to lower the emissions of greenhouse gases such as CO<sub>2</sub>, CH<sub>4</sub>, CO, and N<sub>2</sub>O, which are pollutants responsible for causing climate change and pollutants responsible for causing climate change [1]. Consequently, the nation has made a commitment to reduce its greenhouse gas emissions to net-zero [2]. The objective of these actions is to achieve the ambitious global net-zero emission target, with the aim of limiting the rise in global temperatures to 1.5 °C by 2050 [3]. As a fundamental element of the overarching strategy for the reduction of carbon emissions, the utilization of renewable energy sources, including solar photovoltaic installations and hydro-power, is a matter of national concern. Solar photovoltaic (PV) technology is widely regarded as one of the most effective measures available to reduce carbon emissions in the production of electricity [4]. Generation systems have been identified as a potentially effective solution for mitigating climate change and enhancing energy security [4].

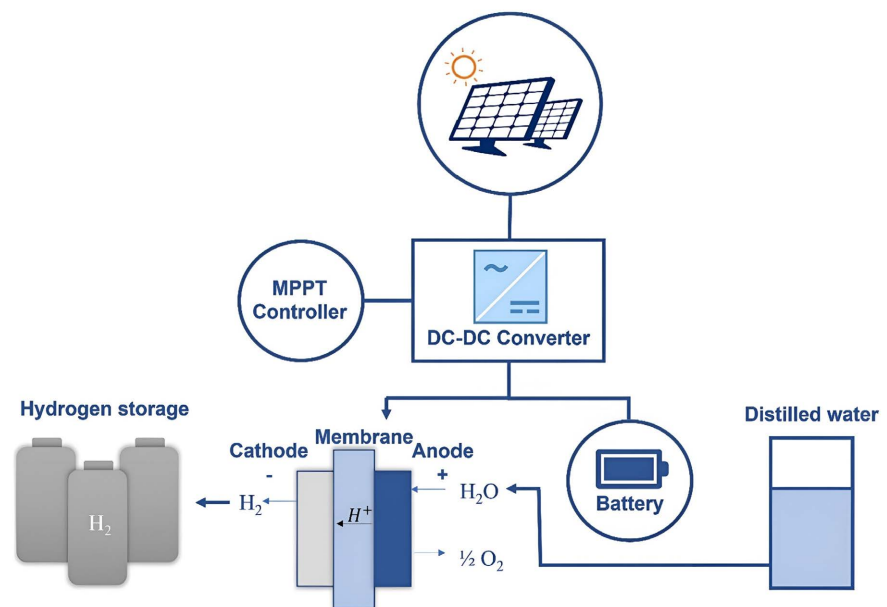

**Figure 1.** Photovoltaic-driven hydrogen production system diagram.

Apart from the renewable energies mentioned above, green hydrogen (GH<sub>2</sub>), which is produced using renewable energy sources, is a sustainable energy source that has significant potential for reducing reliance on fossil fuels and contributing to the global transition to a low-carbon economy [5]. Green hydrogen, produced from solar power is being regarded with an increasing degree of interest as a key solution for decarbonizing various sectors and transitioning to a sustainable energy future [6] [7]. More, the integration of solar photovoltaic (PV) systems with water-splitting units for the generation of green hydrogen represents a promising area of research that is garnering significant attention [8]. The utilization of pho-

photovoltaic (PV) technology as an energy source for  $\text{GH}_2$  is classified as solar-hydrogen (S-H) systems [9], also called Photovoltaic-based hydrogen production [4]. The principle is shown in **Figure 1**. The principal components of S-H systems comprise the photovoltaic (PV) generator, which is responsible for the generation of electricity from sunlight, and the electrolyzer, which utilizes this energy [9]. The process of electrolysis is the means by which electric energy is utilized to split water into hydrogen ( $\text{H}_2$ ) and oxygen ( $\text{O}_2$ ). At the present time, there are three water electrolysis technologies that are available for commercial exploitation [10]:

- alkaline electrolysis,
- proton exchange membrane (PEM),
- solid oxide electrolysis.

Each technology offers distinct benefits in the context of large-scale production [11] [12]. But PEM technology will become the most prevalent method cause it demonstrates a rapid response to fluctuations in renewable energy sources [13]. The system has been designed in a modular way; the high current density and high purity of the  $\text{H}_2$  production are significant features [14].

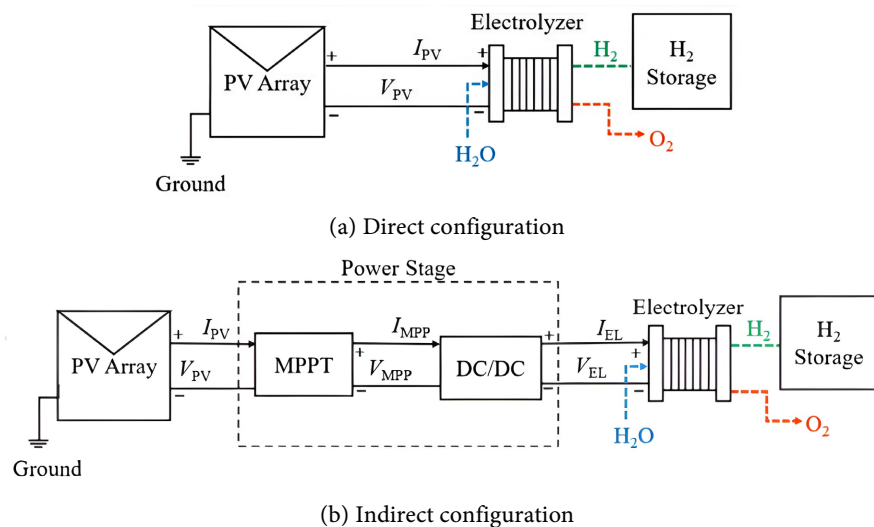

**Figure 2.** Schematic depicting the direct and indirect coupling configurations.

Two types of Photovoltaic-based hydrogen production configurations are available [9]:

- The direct configuration **Figure 2(a)**: the electrolyzer input is directly connected to the PV generator's electrical output, without an intermediate power stage [9].
- The indirect configuration **Figure 2(b)**: use electronics to bias the PV generator at its greatest power point and send this power to the electrolyzer [9].

A number of studies have analyzed the hydrogen potential from renewable energy sources using various approaches. Using an artificial neural network kriging technique, [15] suggested a regional decision support system for on-site renewable hydrogen generation from solar and wind energy sources. [16] and [17] found

that the tilt angle of solar panels affects hydrogen generation rates and should be considered in a comprehensive solar-based hydrogen study. [18] and [19] conducted a study in Paraguay to assess the potential for GH<sub>2</sub> production from hydropower, solar, and wind resources. The study found that small hydropower resources have an estimated potential of 24,904 t. year<sup>-1</sup> for end-use applications and fossil fuel replacement. [20] conducted a study to explore the potential of GH<sub>2</sub> energy as a low-carbon fuel in Nigeria's energy mix. The study emphasizes the importance of distributed energy access, including GH<sub>2</sub> technologies, for increasing electrification and achieving the country's carbon neutrality goals. [21] investigated how electricity from hydropower generation could be used to generate GH<sub>2</sub> in Turkey. According to their study, hydroelectric energy has the potential to increase GH<sub>2</sub> production by 2.26 Mt, propelling the country to the forefront. Using five scenarios to explore green hydrogen production from the Jebba Hydropower station for Nigeria's clean energy transition, [22] found that the first scenario indicated that the highest potential was 59,111 t with a re-electrification potential of 1182 GWh. This could replace 0.224 million liters of petrol, preventing 0.52 million kg of CO<sub>2</sub> and 0.92 thousand kg of CO emissions in 2021.

## 2. Statement of the Problem

There is growing international agreement on the use of emission-free or clean hydrogen in sustainable transportation [22]. For example, China and South Korea have expressed plans to expand their fleets of fuel cell electric vehicles and hydrogen fueling facilities by 2030 [23]. Some European and North American countries with a high penetration of renewable energy sources are seeking long-term mass production of clean hydrogen for residential use [22]. So, the research discussed above used various approaches to analyze the available potential for wind, solar energy, and hydroelectricity, as well as the global hydrogen potential around some parts of the world. The objective of this study is to assess the green hydrogen production GH<sub>2</sub> over the whole thirteen regions of Burkina Faso. To target this precedent objective, we used fixed Photovoltaic-based hydrogen production, using the direct configuration to compute the quantities of GH<sub>2</sub> available. The paper is arranged in the following sections: studied area, data, materials, and methods. Section 3 presents the results and discussion, while Section 4 ends the paper and highlights the possible implications of the study's findings.

## 3. Materials and Methods

### 3.1. Solar Data and Studied Area

For this study, we use the long-term yearly average of global irradiation at optimum tilt angle for Burkina Faso, covering the period from 1994 to 2018. These data are from the WORLD BANK database [24]. The Burkina Faso presented in **Figure 3** is the studied area. It is a Sahelian country located in Western Africa between latitudes 9° and 15° north, and longitudes 6° west to 3° East. Burkina Faso has a surface area of 274,200 km<sup>2</sup> and is characterized by significant interan-

nual climate variability.



**Figure 3.** Considered region.

### 3.2. Electrolyzer Model

Electrolysis is the process by which water is split into hydrogen and oxygen using electricity or electrical energy. The electrolyzer **Figure 4**, is the instrument that transforms a portion of the electrical energy that is given into chemical energy. In this study, we utilize the PEM electrolyzer because of its proven efficiency and popularity in the energy industry [9]. This method uses a solid polymeric PEM to separate the anode (oxidation electrode) from the cathode (reduction electrode) [9]. Green hydrogen is the name given to the hydrogen generated when the energy used to power the electrolyzers originates from a renewable source [25]. There is also grey hydrogen produced from fossil fuels and blue hydrogen produced from natural gas with carbon [4]. The reason for the use of PEM is its high rate of hydrogen synthesis, purity of gases, and energy efficiency [26]. Numerous research [27]-[32] estimated hydrogen generation using the PEM. With an efficiency of 75% [27]-[32], the electrolyzer is expected to use 53 kWh to produce 1 kg of hydrogen [32].

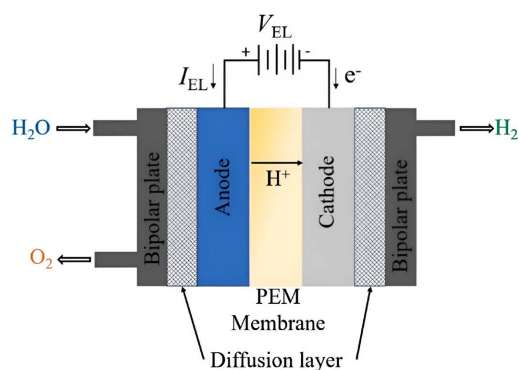

**Figure 4.** Schematic of an ideal PEM cell [12].

### 3.3. Hydrogen Production from a Solar Energy Conversion System

Solar PV arrays, a power conversion system, and a water electrolysis system make up the solar energy-to-hydrogen conversion system. The water electrolysis conversion process in the solar energy-to-hydrogen conversion system uses a PEM electrolysis system with 54 kWh per kilogram of hydrogen [27]. A crystalline silicon panel with an efficiency of 17% and a panel density of 0.337 (acceptable density to minimize shading) [33] is the solar PV technology in use [32]. Equation 1 defines the electricity generated by the solar energy conversion system:

$$E_{solar} (\text{Wh} \cdot \text{year}^{-1}) = GTI \cdot S_{coverarea} (\text{m}^2) \cdot \eta_{PV} \eta_{pc} \eta_{pf} \eta_{derating} \quad (1)$$

**Table 1.** Input parameters for the solar energy-to-hydrogen conversion [29].

Parameter	Value	Comments/Sources
Photovoltaic panel efficiency ( $\eta_{PV}$ )	17%	The average efficiency level of standard commercial crystalline solar PV cells [32]
Panel density	0.337	Acceptable density to minimize shading [33]
Packing factor ( $\eta_{pf}$ )	89%	Value for crystalline solar PV cells [34]
Derating factor ( $\eta_{derating}$ )	77%	[35]
Power conditioning efficiency ( $\eta_{pc}$ )	85%	Conservative estimate from [32]
Electrolysis system efficiency ( $\eta_{elec}$ )	75%	[32]
Electrolyzer electrical energy demand ( $E_{elec}$ )	54 kWh.kg <sup>-1</sup>	For PEM electrolyzer [27]

Equation 2 governs the mass of hydrogen (kg) generated by the solar energy-to-hydrogen conversion system, while Equation 2 calculates the swept area availability of the solar farm.

**Table 1** presents characteristics of input parameters used in Equation 1, Equation 2, and Equation 3 for the solar energy-to-hydrogen conversion analysis. To estimate the potential for producing hydrogen from electrical energy, the following scenarios are considered: use of the available suitable area of each region, and we consider only 10% of solar energy from these areas.

$$M_{H_2} (\text{kg} \cdot \text{year}^{-1}) = \frac{E_{solar} \eta_{elec}}{E_{elec}} \quad (2)$$

$$S_{coverarea} = \text{suitable area} (\text{m}^2) \times \text{PV panel\_spacingdensity} \quad (3)$$

$$S_{coverarea} = \text{suitable area} (\text{m}^2) \times \text{PV panel\_spacingdensity} \quad (4)$$

### 3.4. Re-Electrification Potential Using Fuel Cell

Hydrogen energy has the potential to help re-electrify rural areas, mainly in villages without grid electricity [22]. More, electricity produced from hydrogen

could replace fossil fuel-based energy sources in the home and industrial sectors, such as gasoline or diesel generators [36]. It is estimated that 1 kg of GH<sub>2</sub> may provide 20 kWh of power with present technology (4.5 Mt GH<sub>2</sub>/90 TWh) [37], while in another article [29], according to thermodynamic properties, 1 kilogram of hydrogen contains 33.3 kWh  $\approx$  120.1 MJ (lower heating value). Equation 5, which uses hydrogen for re-electrification, shows the potential for this process. We use that 20 kWh of energy can be produced from 1 kilogram GH<sub>2</sub>.

$$RE_p \text{ (GWh)} = \frac{20}{1000} \cdot M_{H_2} \quad (5)$$

### 3.5. Estimation of Fossil Fuel (Petrol) Replacement

One kilogram of GH<sub>2</sub> can replace 3.785 L of petrol [36], while 1 kg of hydrogen has the same energy content as one US gallon of gasoline [38]. We use the following equation (Equation 6) to assess the quantities of petrol that could be avoided by using GH<sub>2</sub>.

$$PR(L) = M_{H_2} \times 3.785 \quad (6)$$

### 3.6. Estimation of Greenhouse Gases Avoided

This part aims to estimate the amount of CO<sub>2</sub> and CO (Equation 7) that could be avoided if hydrogen were used instead of petrol (or gasoline).

$$CO_2 \text{ or CO (kg} \cdot L^{-1}) = PR \cdot SE_F \quad (7)$$

$SE_F$  is the specific emission factor of the corresponding greenhouse gas. For CO<sub>2</sub>,  $SE_F = 2.3 \text{ kg} \cdot L^{-1}$  while  $SE_F = 0.00413 \text{ kg} \cdot L^{-1}$  for CO [39].

## 4. Results and Discussions

### 4.1. Technical Potential of GH<sub>2</sub> Production with Solar PV Yield

As illustrated in **Figure 5(b)**, the mean solar PV potential energy over the entire country has been presented on an annual basis for the period 1994 - 2018. This result is derived from Equation 1, using global irradiation at optimal tilt present in **Figure 5(a)**. The distribution of potential from solar-powered electrolysis across Burkina Faso is uniform, with elevated levels observed in the northern regions of the country. The results of the suitable area, annual solar PV energy, and Green Hydrogen GH<sub>2</sub> potential estimation are displayed in **Table 2**, while the yearly Potential energy production by region is shown in **Figure 6**. Using only 10% of solar PV which corresponds to 2591.85 MWh.year<sup>-1</sup> for the entire region, the annual hydrogen production potential can reach up to 36 tons.year<sup>-1</sup>. The highest and the lowest annual hydrogen production potential are 6.12 and 0.38 tons.year<sup>-1</sup>. Concerning the potential of GH<sub>2</sub> energy, the production reaches 720 MWh.year<sup>-1</sup>. The highest and the lowest annual GH<sub>2</sub> energy production potential are respectively 122.4 and 7.6 MWh.

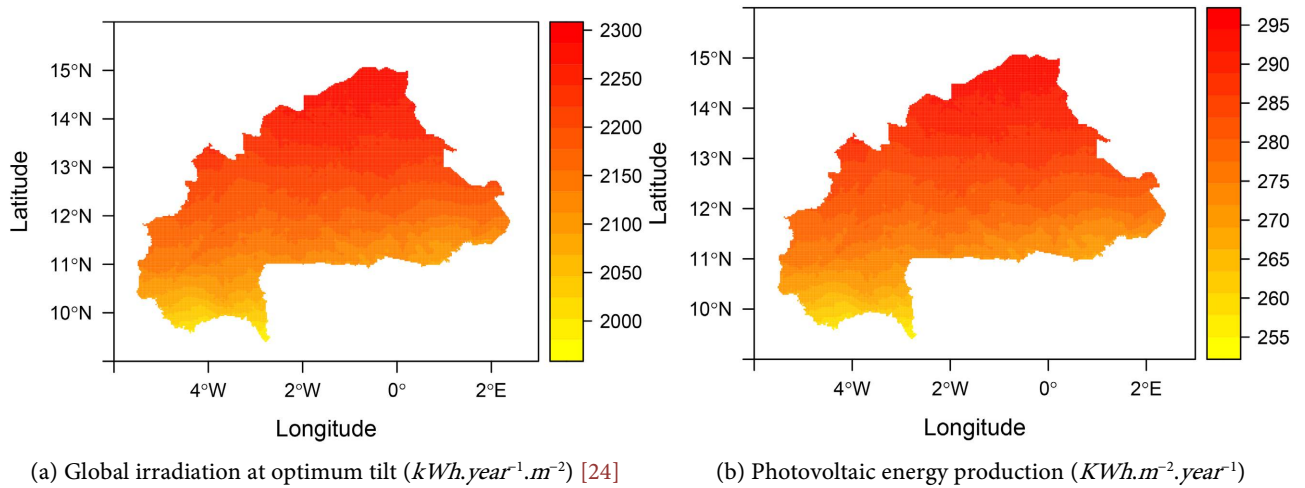

**Figure 5.** Solar irradiation repartition and solar PV energy potential.

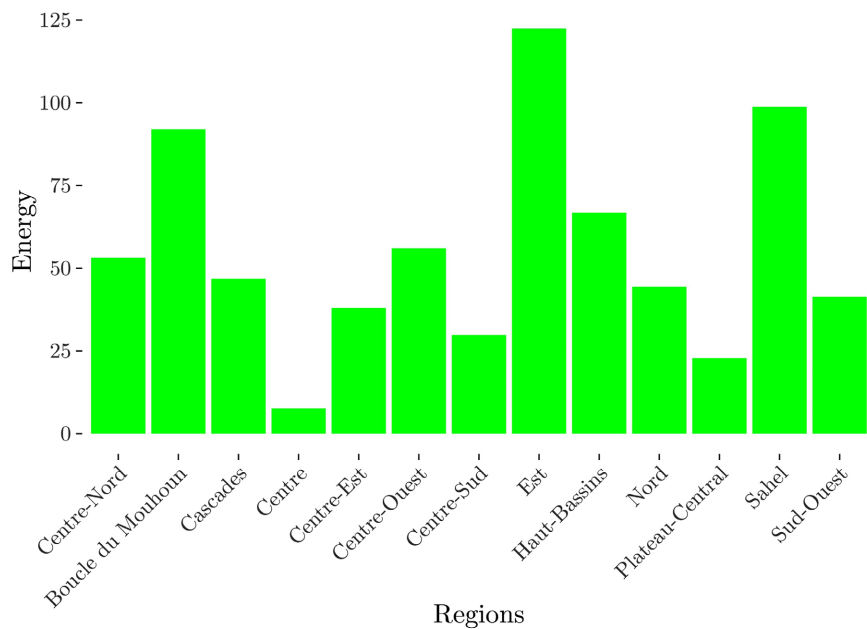

**Figure 6.** Potential energy ( $GWh.year^{-1}$ ) production by region.

#### 4.2. Evaluation of Fossil Fuel (Petrol) Replacement and Estimation of Greenhouse Gases Avoided

The results of the estimated amount of annual petrol (or gasoline) replacement with hydrogen by each region are displayed in **Figure 7**. **Figure 8** and **Figure 9** show the quantity of annual greenhouse gases  $CO_2$  and  $CO$  emissions that could be prevented. It is estimated that the quantity of petrol (or gasoline) is 136252.7 liters. Using hydrogen produced from 10% solar PV energy, the maximum and minimum amounts of petrol that can be substituted with hydrogen are respectively 23153.72 and 1440.72 liters. In accordance with the stipulated conditions, the replacement of petrol (or gasoline) has the potential to prevent 313.38 tons of  $CO_2$  on a national scale. In terms of  $CO$ , the utilisation of hydrogen has the po-

tential to engender a reduction of 562.71 kg on a national scale. The substitution of petrol for hydrogen in the re-electrification of rural communities lacking adequate energy access has the potential to contribute to a reduction in greenhouse gas (CO<sub>2</sub> and CO) emissions in Burkina Faso.

**Table 2.** Technical potentials across the country in locations of suitable area, PV energy, GH<sub>2</sub>.

Regions	Suitable area	Solar PV energy	Green Hydrogen
	(m <sup>2</sup> )	MWh.year <sup>-1</sup>	T.year <sup>-1</sup>
Boucle du Mouhoun	346790.74	330.92	4.6
Cascades	186492.72	168.17	2.34
Centre	28803.17	27.41	0.38
Centre-Est	147021.34	136.68	1.9
Centre-Nord	197438.95	191.34	2.66
Centre-Ouest	214708.18	201.81	2.8
Centre-Sud	115211.33	107.42	1.49
Est	467485.32	440.44	6.12
Haut-Bassins	257200.23	240.35	3.34
Nord	164781.8	160.04	2.22
Plateau-Central	86366.66	82.36	1.14
Sahel	62891.85	355.83	4.94
Sud-Ouest	164862.79	149.08	2.07

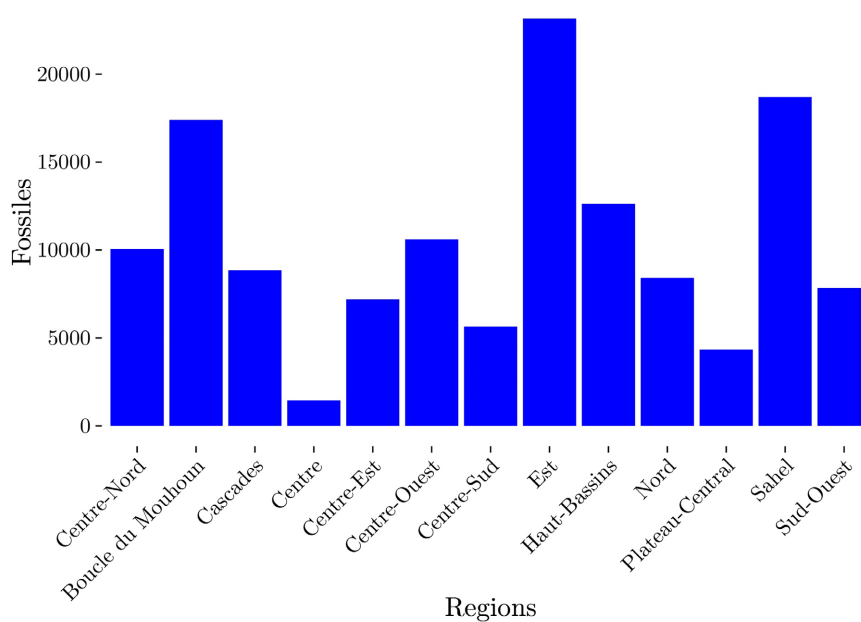

**Figure 7.** Amount of annual fuel (or gasoline) substitution by hydrogen (liters.year<sup>-1</sup>) production by region.

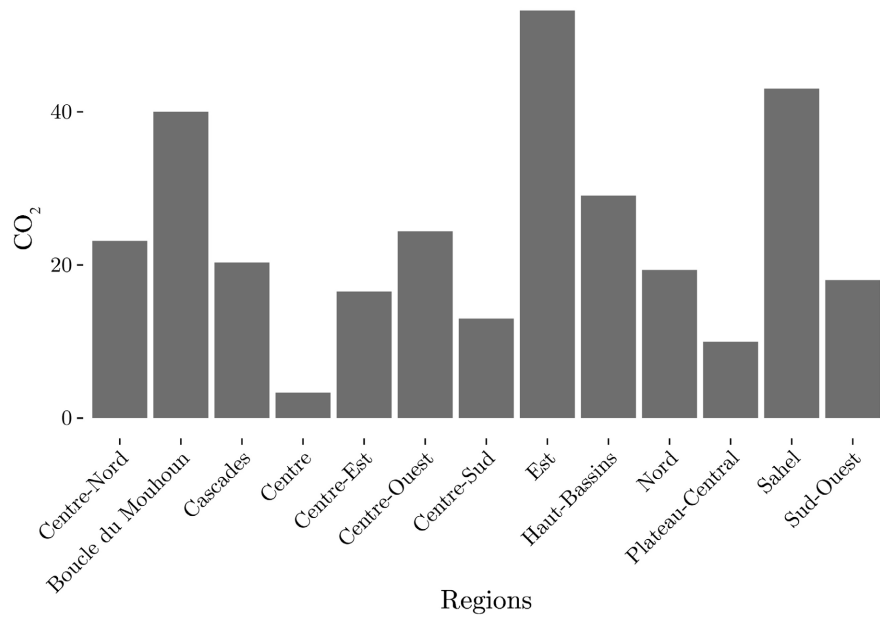

**Figure 8.** Amount of annual CO<sub>2</sub> emissions (kg) avoided using GH<sub>2</sub> by region.

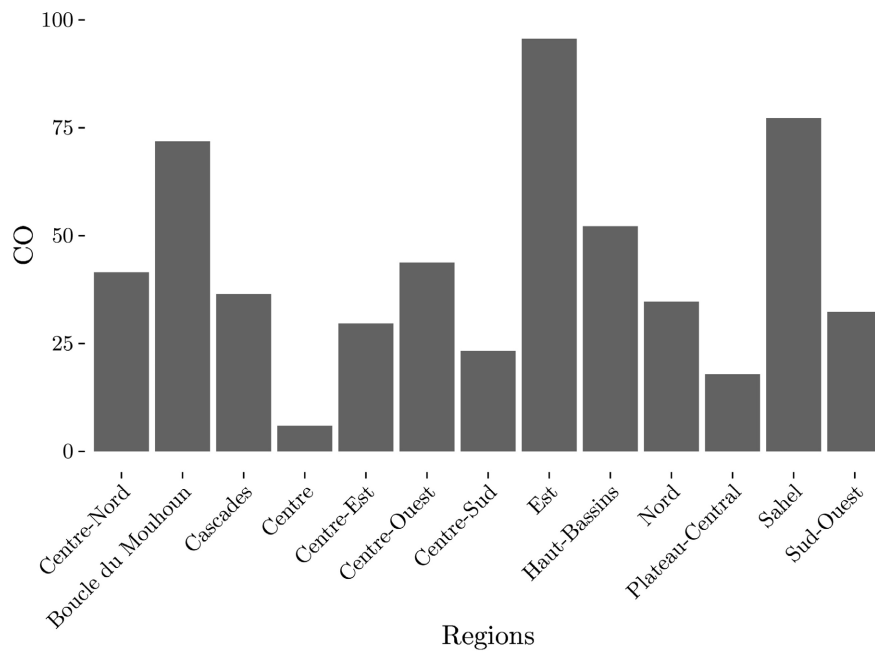

**Figure 9.** Amount of annual CO emissions (kg) avoided using GH<sub>2</sub> by region.

This phenomenon has the potential to contribute to a reduction in the year’s total CO<sub>2</sub> emissions, which part driven by the combustion of fossil fuels (7.02 MtCO<sub>2</sub>), as reported by [40]. This gradual emission reduction, when implemented across all sectors, has the potential to enhance the country’s climate change mitigation efforts and carbon neutrality goals. As part of its energy policy, Burkina Faso has undertaken a significant transition towards renewable energy sources. This approach is part of a commitment to guarantee universal access to electricity,

a crucial objective for the country's socio-economic development. As part of this study, two agencies have been created: the National Agency for Renewable Energy and Efficiency (ANAREE) and the Burkina Faso Agency for Rural Electricity (ABER). With this study, only 10% of solar PV energy production for GH<sub>2</sub> production for re-electrification and replacing fossil fuel generators with hydrogen fuel cell generators will provide environmental benefits and reduce air pollution, as evidenced by the reduction of CO<sub>2</sub> and CO emissions. This integration can drive the vision of Burkina Faso's carbon neutrality and net-zero goal by 2060 (Climate Action Tracker 2023), bringing economic benefits through additional revenue generation from GH<sub>2</sub> exports, fostering the development and creation of new jobs within the energy sector, and contributing to the achievement of the United Nations's Sustainable Development Goals (SDGs), particularly SDG 7 (Affordable and Clean Energy) and SDG 13 (Climate Action), which emphasized the importance of sustainable energy solutions in achieving broader development objectives.

### 4.3. Deficiency of This Research Paper

However, it is important to note that certain limitations may potentially compromise the validity of the study results. Initially, it is important to note that the data used for the computation of global irradiation at optimum tilt encompasses a comparatively limited period (1994-2018). In contrast, the climatological data sets require three decades of observations. Secondly, the study has not adequately evaluated the areas most suitable for the generation of PV energy. Further investigations could entail the use of raster and polygon data pertaining to water bodies, protected areas, and forests, with a view to achieving greater accuracy in the evaluation of suitable land. This would facilitate the identification of viable land within the spatial model. Finally, for a period of several months, Burkina Faso has been divided administratively into 17 regions. This is not updated because the data is of a shapefile nature. For that we use the previous shapefile which, we use the previous shapefile, which comprises thirteen regions.

## 5. Conclusions and Suggestions

This work presents fixed Photovoltaic-based hydrogen production using the direct configurations for annual GH<sub>2</sub> production for Burkina Faso. The study uses the yearly average of global irradiation at the optimum tilt angle for Burkina to assess:

- The yearly amount of green hydrogen potential production. The potential amount of energy that could be used for re-electrification per year
- The potential amount of fossil fuel (petrol) that could be replaced per year
- The potential amount of greenhouse gases (CO & CO<sub>2</sub>) that can be prevented by year

Using only 1/100,000 of each region surface and 10% of solar PV energy from these surfaces, the production of solar PV energy reaches 2591.85 MWh.year<sup>-1</sup> which lead to GH<sub>2</sub> production can reach region's surface and 10% of solar PV

energy from these surfaces, the production of solar PV energy reaches 2591.85 MWh.year<sup>-1</sup>, which leads to GH<sub>2</sub> production reaching up to 36 tons.year<sup>-1</sup>. The highest and lowest values are respectively 6.12 and 0.38 tons.year<sup>-1</sup>. A total amount of 136252.7 L per year could be replaced with this potential amount replaced with this potential amount of GH<sub>2</sub> for the whole country. Concerning the potential of GH<sub>2</sub> energy, the production reaches 720 MWh.year<sup>-1</sup>. The highest and the lowest annual GH<sub>2</sub> energy production potential are respectively 122.4 and 7.6 MWh. The results on greenhouse gas emissions show that 313.38 tons and 562.71 kg respectively for CO<sub>2</sub> and CO could be prevented per year. This study could lead to alternative axes of reflection:

- Using wind, hydropower, and Concentrated solar cells (CSP) as renewable sources to produce GH<sub>2</sub>.
- Investigate the behavior of each type of electrolyzer under Burkina Faso climate conditions.
- Compare renewable energy sources to determine which are best for the country.

In conclusion, the study's findings show that fixed Photovoltaic-based hydrogen systems have the potential to transform the country's energy landscape and enhance its carbon neutrality goal. These results could help to strengthen the country's legislative and regulatory structure, as well as its efforts to transition to a clean energy future.

## Conflicts of Interest

The authors declare no conflicts of interest regarding the publication of this paper.

## References

- [1] Adeoti, O., Ayelegun, T.A. and Osho, S.O. (2014) Nigeria Biogas Potential from Livestock Manure and Its Estimated Climate Value. *Renewable and Sustainable Energy Reviews*, **37**, 243-248. <https://doi.org/10.1016/j.rser.2014.05.005>
- [2] International Energy Agency (2021) Net Zero by 2050: A Roadmap for the Global Energy Sector. Revised Version. International Energy Agency.
- [3] Lee, H., Calvin, K., Dasgupta, D., Krinner, G., Mukherji, A., Thorne, P., Trisos, C., *et al.* (2023) Climate Change 2023: Synthesis Report. Contribution of Working Groups I, II and III to the Sixth Assessment Report of the Intergovernmental Panel on Climate Change. <http://www.ipcc.ch/>
- [4] Al-Ali, S., Olabi, A.G. and Mahmoud, M. (2025) A Review of Solar Photovoltaic Technologies: Developments, Challenges, and Future Perspectives. *Energy Conversion and Management: X*, **27**, Article 101057. <https://doi.org/10.1016/j.ecmx.2025.101057>
- [5] Schwartz, A. and Bell, J. (2018) Temperature-Related Mortality Impacts under and beyond Paris Agreement Climate Change Scenarios. *Climatic Change*, **150**, 391-402.
- [6] Liu, J., Abbas, Q., Alharthi, M., Mohsin, M., Rasul, F. and Iqbal, N. (2021) Managerial Policy and Economic Analysis of Wind-Generated Renewable Hydrogen for Light-Duty Vehicles: Green Solution of Energy Crises. *Environmental Science and Pollution Research*, **28**, 10642-10653. <https://doi.org/10.1007/s11356-020-11018-1>

- [7] Grüger, F., Hoch, O., Hartmann, J., Robinius, M. and Stolten, D. (2019) Optimized Electrolyzer Operation: Employing Forecasts of Wind Energy Availability, Hydrogen Demand, and Electricity Prices. *International Journal of Hydrogen Energy*, **44**, 4387-4397. <https://doi.org/10.1016/j.ijhydene.2018.07.165>
- [8] Abdelkareem, M.A., Abdelghafar, A.A., Mahmoud, M., Sayed, E.T., Mahmoud, M.S., Alami, A.H., *et al.* (2023) Optimized Solar Photovoltaic-Powered Green Hydrogen: Current Status, Recent Advancements, and Barriers. *Solar Energy*, **265**, Article 112072. <https://doi.org/10.1016/j.solener.2023.112072>
- [9] González del Valle, A., García-Linares, P. and Martí, A. (2024) Optimizing Hydrogen Production: A Comparative Study of Direct and Indirect Coupling between Photovoltaics and Electrolyzer. *Energy Conversion and Management*, **315**, Article 118751. <https://doi.org/10.1016/j.enconman.2024.118751>
- [10] Buitendach, H.P.C., Gouws, R., Martinson, C.A., Minnaar, C. and Bessarabov, D. (2021) Effect of a Ripple Current on the Efficiency of a PEM Electrolyser. *Results in Engineering*, **10**, Article 100216. <https://doi.org/10.1016/j.rineng.2021.100216>
- [11] Bessarabov, D., Wang, H., Li, H. and Zhao, N. (2016) PEM Electrolysis for Hydrogen Production: Principles and Applications. CRC Press.
- [12] Zorica, S., Vukšić, M. and Betti, T. (2019) Design Considerations of the Multi-Resonant Converter as a Constant Current Source for Electrolyser Utilisation. *International Journal of Electrical Power & Energy Systems*, **111**, 237-247. <https://doi.org/10.1016/j.ijepes.2019.04.019>
- [13] Schmidt, O., Gambhir, A., Staffell, I., Hawkes, A., Nelson, J. and Few, S. (2017) Future Cost and Performance of Water Electrolysis: An Expert Elicitation Study. *International Journal of Hydrogen Energy*, **42**, 30470-30492. <https://doi.org/10.1016/j.ijhydene.2017.10.045>
- [14] Rashid, M.M., Al Mesfer, M.K., Naseem, H., Danish, M., *et al.* (2015) Hydrogen Production by Water Electrolysis: A Review of Alkaline Water Electrolysis, Pem Water Electrolysis and High Temperature Water Electrolysis. *International Journal of Engineering Advanced Technology*, **4**, 2249-8958,.
- [15] Dagdougui, H., Ouammi, A. and Sacile, R. (2011) A Regional Decision Support System for Onsite Renewable Hydrogen Production from Solar and Wind Energy Sources. *International Journal of Hydrogen Energy*, **36**, 14324-14334. <https://doi.org/10.1016/j.ijhydene.2011.08.050>
- [16] Ghribi, D., Khelifa, A., Diaf, S. and Belhamel, M. (2013) Study of Hydrogen Production System by Using PV Solar Energy and PEM Electrolyser in Algeria. *International Journal of Hydrogen Energy*, **38**, 8480-8490. <https://doi.org/10.1016/j.ijhydene.2012.09.175>
- [17] Mraoui, A. and Menia, S. (2019) Renewable Electrolytic Hydrogen Potential in Algeria. *International Journal of Hydrogen Energy*, **44**, 26863-26873. <https://doi.org/10.1016/j.ijhydene.2019.08.134>
- [18] Posso, F. and Zambrano, J. (2014) Estimation of Electrolytic Hydrogen Production Potential in Venezuela from Renewable Energies. *International Journal of Hydrogen Energy*, **39**, 11846-11853. <https://doi.org/10.1016/j.ijhydene.2014.06.033>
- [19] Posso, F., Galeano, M., Baranda, C., Franco, D., Rincón, A., Zambrano, J., *et al.* (2022) Towards the Hydrogen Economy in Paraguay: Green Hydrogen Production Potential and End-Uses. *International Journal of Hydrogen Energy*, **47**, 30027-30049. <https://doi.org/10.1016/j.ijhydene.2022.05.217>
- [20] Shari, B.E., Moumouni, Y., Ohunakin, O.S., Blechinger, P., Madougou, S. and Rabani, A. (2024) Exploring the Role of Green Hydrogen for Distributed Energy Access Plan-

- ning Towards Net-Zero Emissions in Nigeria. *Sustainable Energy Research*, **11**, Article No. 16. <https://doi.org/10.1186/s40807-024-00107-1>
- [21] Karayel, G.K., Javani, N. and Dincer, I. (2022) Green Hydrogen Production Potential in Turkey with Wind Power. *International Journal of Green Energy*, **20**, 129-138. <https://doi.org/10.1080/15435075.2021.2023882>
- [22] Aremu, E.O., Lawin, A.E., Olukanni, D. and Franssen, H.H. (2024) Estimation of Green Hydrogen Production Potentials from Exploitable Hydropower Resources for Re-Electrification and Climate Change Mitigation in Nigeria. In: Narra, MM. and Narra, S., Eds., *World Sustainability Series*, Springer Nature, 195-208. [https://doi.org/10.1007/978-3-031-68330-5\\_11](https://doi.org/10.1007/978-3-031-68330-5_11)
- [23] Fan, L., Tu, Z. and Chan, S.H. (2021) Recent Development of Hydrogen and Fuel Cell Technologies: A Review. *Energy Reports*, **7**, 8421-8446. <https://doi.org/10.1016/j.egy.2021.08.003>
- [24] World Bank Group (2025) Longterm Yearly Average of Global Irradiation at Optimum Tilt-Burkina Faso-Global Solar Atlas 2.0. <https://globalsolaratlas.info/download/burkina-faso>
- [25] Sow, E.A., Vall, M.M., Abidine, M.M., Babah, H., Hamoud, A., Faye, G., et al. (2024) Assessment of Green Hydrogen Production Potential from Solar and Wind Energy in Mauritania. *Geographia Technica*, **19**, 1-12. [https://doi.org/10.21163/gt\\_2024.192.01](https://doi.org/10.21163/gt_2024.192.01)
- [26] Ueda, S., Hemeida, A.M., Krishna, N., Rangarajan, S., Collins, E.R., Mikhaylov, A., et al. (2022) Optimal Renewable Energy Configuration in Smart Cities Considering Shortened Annual Simulation. *SSRN Electronic Journal*, 14 p. <https://doi.org/10.2139/ssrn.4164019>
- [27] Ayodele, T.R. and Munda, J.L. (2019) Potential and Economic Viability of Green Hydrogen Production by Water Electrolysis Using Wind Energy Resources in South Africa. *International Journal of Hydrogen Energy*, **44**, 17669-17687. <https://doi.org/10.1016/j.ijhydene.2019.05.077>
- [28] Folgado, F.J., González, I. and Calderón, A.J. (2022) Simulation Platform for the Assessment of PEM Electrolyzer Models Oriented to Implement Digital Replicas. *Energy Conversion and Management*, **267**, Article 115917. <https://doi.org/10.1016/j.enconman.2022.115917>
- [29] Okunlola, A., Davis, M. and Kumar, A. (2022) The Development of an Assessment Framework to Determine the Technical Hydrogen Production Potential from Wind and Solar Energy. *Renewable and Sustainable Energy Reviews*, **166**, Article 112610. <https://doi.org/10.1016/j.rser.2022.112610>
- [30] Posso, F., Sánchez, J., Espinoza, J.L. and Siguencia, J. (2016) Preliminary Estimation of Electrolytic Hydrogen Production Potential from Renewable Energies in Ecuador. *International Journal of Hydrogen Energy*, **41**, 2326-2344. <https://doi.org/10.1016/j.ijhydene.2015.11.155>
- [31] Rahmouni, S., Negrou, B., Settou, N., Dominguez, J. and Gouareh, A. (2017) Prospects of Hydrogen Production Potential from Renewable Resources in Algeria. *International Journal of Hydrogen Energy*, **42**, 1383-1395. <https://doi.org/10.1016/j.ijhydene.2016.07.214>
- [32] Touili, S., Alami Merrouni, A., Azouzoute, A., El Hassouani, Y. and Amrani, A. (2018) A Technical and Economical Assessment of Hydrogen Production Potential from Solar Energy in Morocco. *International Journal of Hydrogen Energy*, **43**, 22777-22796. <https://doi.org/10.1016/j.ijhydene.2018.10.136>
- [33] Zappa, W. and van den Broek, M. (2018) Analysing the Potential of Integrating Wind

- and Solar Power in Europe Using Spatial Optimisation under Various Scenarios. *Renewable and Sustainable Energy Reviews*, **94**, 1192-1216.  
<https://doi.org/10.1016/j.rser.2018.05.071>
- [34] Gaur, A. and Tiwari, G.N. (2013) Performance of Photovoltaic Modules of Different Solar Cells. *Journal of Solar Energy*, **2013**, 1-13. <https://doi.org/10.1155/2013/734581>
- [35] World Bank Group (2018) Solar Pumping: The Basics (English).  
<http://documents.worldbank.org/curated/en/880931517231654485>
- [36] Thapa, B.S., Neupane, B., Yang, H. and Lee, Y. (2021) Green Hydrogen Potentials from Surplus Hydro Energy in Nepal. *International Journal of Hydrogen Energy*, **46**, 22256-22267. <https://doi.org/10.1016/j.ijhydene.2021.04.096>
- [37] Ayodele, T.R. and Munda, J.L. (2019) Potential and Economic Viability of Green Hydrogen Production by Water Electrolysis Using Wind Energy Resources in South Africa. *International Journal of Hydrogen Energy*, **44**, 17669-17687.  
<https://doi.org/10.1016/j.ijhydene.2019.05.077>
- [38] Ale, B.B. and Bade Shrestha, S.O. (2008) Hydrogen Energy Potential of Nepal. *International Journal of Hydrogen Energy*, **33**, 4030-4039.  
<https://doi.org/10.1016/j.ijhydene.2008.04.056>
- [39] Ayodele, T.R. and Ogunjuyigbe, A.S.O. (2015) Increasing Household Solar Energy Penetration through Load Partitioning Based on Quality of Life: The Case Study of Nigeria. *Sustainable Cities and Society*, **18**, 21-31.  
<https://doi.org/10.1016/j.scs.2015.05.005>
- [40] Climate Watch (2022) Burkina Faso GHG Emissions.  
<https://www.climatewatchdata.org/countries/BFA?endyear=2022&startyear=1990#ghg-emissions>