

# Economic Growth in Emerging Markets: The Influence of Foreign Direct Investment on Renewable Energy

John Agbana, Abbas Abubakar, Mustapha Babani Abdullahi, Olajide Oladipo, Ifeyinwa Arinze-Emefo

Department of Business Administration, Nile University of Nigeria, Abuja, Nigeria  
Email: agbana.john@yahoo.com

**How to cite this paper:** Agbana, J., Abubakar, A., Abdullahi, M. B., Oladipo, O., & Arinze-Emefo, I. (2024). Economic Growth in Emerging Markets: The Influence of Foreign Direct Investment on Renewable Energy. *Open Journal of Business and Management*, 12, 2683-2708.  
<https://doi.org/10.4236/ojbm.2024.124139>

**Received:** May 14, 2024

**Accepted:** July 22, 2024

**Published:** July 25, 2024

Copyright © 2024 by author(s) and Scientific Research Publishing Inc. This work is licensed under the Creative Commons Attribution International License (CC BY 4.0).

<http://creativecommons.org/licenses/by/4.0/>



Open Access

## Abstract

The importance of energy for the growth and development of any country cannot be overemphasized considering the attendant effect of the inflow of foreign direct investment (FDI) into the country concerned. This study thus, explores the impact of economic factors chiefly the FDI, unemployment rate (UNF), inflation rate (INF), exchange rate (EXR) and GDP on the hydropower production (HDP) in Nigeria. The data used for this study encompasses a quantitative data between the year 1970 and 2023 leading to 54 observations. The applied analytical methods include those of normality test, correlation, cross dependency, unit root test and Ordinary Least Square Structural Equation Modeling (PLS-SEM). The result indicates that with a regression coefficient of  $-0.245$  and a Pr (0.827) for GDP,  $0.0609$  and a Pr (1.40) for INF,  $-0.655$  and Pr (.390) for UNF, and  $-0.523$  with a Pr (0.458) for FDI, it shows that the aforementioned variables does not have impact on the HDP. However, with a regressor value of  $-0.040$  and a Pr (0.000) for EXR, it posits that only exchange rate has impact on the HDP for the period under review. This study concluded that only exchange rate has structural relationship with hydropower production in Nigeria while the other economic factors of inflation, unemployment and FDI do not historically have impact on the level of hydropower production in Nigeria. This study recommended that controlling the rate of exchange rate is crucial for maintaining hydropower production growth. Failure to do so might lead to a decrease in the productive capacity in hydropower. Also, Nigeria can benefit from increased regional and global collaboration, which includes trade agreements and cross-border infrastructure efforts that enhance connectivity and promote economic integration.

---

## Keywords

Economic Growth, Emerging Markets, Foreign Direct Investment, Renewable Energy Production, Hydropower

---

## 1. Introduction

Emerging markets, including Africa and Nigeria, have witnessed significant economic growth in recent decades and hold immense potential in the renewable energy sector. This growth, driven by globalization, technological advancement, and increasing investment opportunities, has paved the way for focusing on renewable energy, gaining prominence due to environmental concerns and the need for sustainable development. Foreign Direct Investment (FDI) has played a pivotal role in shaping this sector in emerging markets, particularly in Africa. FDI has been instrumental in driving renewable energy projects, leveraging the continent's abundant natural resources, such as water, sunlight, and wind. As one of Africa's largest economies, Nigeria has seen an increase in FDI inflows targeting its renewable energy sector, aiming to address energy poverty and reduce dependency on fossil fuels. The rapid growth in energy consumption in response to economic expansion and industrialization has led to a global focus on transitioning to renewable energy sources. The increasing demands for energy and concerns about rising fossil fuel prices and climate change have also contributed to this. Nigeria, a developing country heavily reliant on energy, faces challenges due to declining domestic oil resources and inadequate infrastructure. Nigeria aims to increase the share of renewable energy in its power generation capacity to reduce dependence on fossil fuels and mitigate pollution. Expanding renewable energy infrastructure in emerging markets, such as Nigeria, significantly impacts various economic indicators (Ibrahiem, 2015). Renewable energy projects, particularly those driven by Foreign Direct Investment (FDI), stimulate economic activity across different sectors, resulting in GDP growth, job creation, and social and economic stability. Additionally, exchange rate stability or appreciation attracts foreign direct investment (FDI) into renewable energy, as it reduces currency risk for investors (Rashed et al., 2021a). Conversely, inflation can impact the attractiveness of investments by influencing project costs and returns. Moderate inflation rates are generally favourable, but high inflation can deter investors. FDI inflows into renewable energy bring capital, technology, and expertise and support energy security and environmental sustainability, providing a solid foundation for sustainable economic growth.

This study's focus on the impact of Foreign Direct Investment (FDI) on renewable energy in emerging markets, with a spotlight on Nigeria, underscores its relevance to policymakers, investors, and stakeholders in the renewable energy sector. It aims to provide essential insights into the relationship between economic growth, sustainability, and the role of renewable energy in driving eco-

conomic development and job creation. The study analyzes crucial economic indicators such as GDP growth, unemployment, exchange rates, inflation, and FDI to offer valuable insights. It identifies barriers and opportunities for renewable energy development, guiding efforts to create favourable investment climates and overcome challenges. Ultimately, the study's significance lies in its potential to inform strategies that promote sustainable development, advance climate action goals, and enhance economic prosperity in emerging markets like Nigeria. By better understanding these relationships, stakeholders can work towards a greener, more resilient future while driving positive economic and environmental changes. This study aims to assess the impact of Foreign Direct Investment (FDI) on developing renewable energy infrastructure in emerging markets, focusing on Nigeria by analyzing its influence on economic growth indicators such as GDP, unemployment, and inflation. In the same vein, it also helps to identify the key factors affecting the attraction and utilization of FDI in the renewable energy sector in emerging markets, with a specific focus on Nigeria, including regulatory frameworks, political stability, exchange rate dynamics, and investment climate, to provide insights for policymakers and investors aiming to promote sustainable energy transitions (Encinas-Ferrer & Villegas-Zermeño, 2015). The significance of renewable energy in sustainable development and the imperative to comprehend how renewable electricity consumption and foreign direct investment influence economic growth in Nigeria. These objectives form the crux of our study, which we believe will contribute significantly to energy economics and sustainable development.

Even though measures are being taken to expedite the realization of these dimensions for economic growth, a question needs to be answered: How does Foreign Direct Investment (FDI) influence the development of renewable energy infrastructure in emerging markets like Nigeria? This question seeks to understand the relationship between Foreign Direct Investment (FDI) and the development of renewable energy infrastructure in emerging markets, mainly focusing on Nigeria. It aims to explore how FDI contributes to the growth of renewable energy projects, job creation, and economic development in these markets (Amin et al., 2022). Renewable energy is becoming increasingly important in emerging markets like Nigeria, but its Foreign Direct Investment (FDI) level remains low. This limited investment hinders the development of renewable energy infrastructure, resulting in continued reliance on fossil fuels, energy insecurity, and environmental degradation. Despite progress in the renewable energy sector, several challenges still need to be addressed (Ptacek et al., 2015). These challenges include inadequate infrastructure, regulatory obstacles, and political instability, which can negatively impact the flow and effectiveness of foreign direct investment (FDI) in this sector. However, overcoming these challenges and creating an environment that enables sustainable investment and technological innovation is essential. Achieving a greener and more prosperous future requires cooperation and concerted efforts from governments, international organiza-

tions, and private investors. Ideally, increased FDI in renewable energy would drive the expansion of sustainable energy sources, create jobs, and promote economic growth while mitigating environmental impacts (Adewole et al., 2023). However, the current state falls short of this expectation, hindering progress towards a greener, more sustainable energy future. Failure to attract sufficient FDI into the renewable energy sector in Nigeria could have significant consequences. It may perpetuate reliance on fossil fuels, exacerbating environmental pollution and contributing to climate change. Additionally, inadequate investment could hinder economic development, limit job opportunities, and undermine efforts to achieve energy security and sustainability goals (Abdi et al., 2024). Without addressing this issue, Nigeria risks falling behind in the global transition towards renewable energy and facing long-term economic and environmental challenges (Sharmiladevi, 2023).

The study employs a novel approach, examining the relationship between renewable electricity consumption, foreign direct investment, and economic growth in Egypt. It builds on existing literature that delves into the interplay between energy consumption, economic development, and foreign direct investment. The study utilizes an ARDL model to scrutinise the data from 1980 to 2011 and conducts Granger causality tests to probe the causal relationships between the variables. Extant literature includes studies such as Abdi et al. (2024), which examined the Asymmetric effects of foreign direct investment and trade openness on economic growth in Somalia: Evidence from a non-linear ARDL approach and found a mixed result. Moreover, John et al. (2023) examined foreign direct investment, remittances, real exchange rate, imports, and economic growth in Ghana: An ARDL approach and found a positive result. Without any missing variables, data was gathered from the World Data Bank. None of the above, however, substituted economic growth in the energy market and foreign direct investment for Gross Domestic Product (GDP), unemployment indicator, consumer spending, inflation rate, and exchange rate. In addition, no one used GDP as a stand-in for measuring the economy's performance. Therefore, this study addresses the gap by evaluating the impact of economic growth in emerging markets: the influence of foreign direct investment in renewable energy in Nigeria. The remainder of the sections will be presented as Literature review, methodology, findings, discussion, and conclusions.

## 2. Literature Review

There are several researchers aimed at focusing on the relationship between economic growth in emerging markets and foreign direct investment in renewable energy, so in this part, some empirical studies will be presented, and they will be divided into two subsections; the first one will be concerned with empirical studies that examined the relationship between emerging markets and economic growth, while the second one will be concerned with those studies that examined the relationship between renewable energy and economic growth.

## 2.1. Conceptual Review

Gross Domestic Product (GDP) is a critical economic indicator that measures the total value of goods and services produced within a country's borders over a specific period. In the context of the influence of Foreign Direct Investment (FDI) on renewable energy in emerging markets like Nigeria, GDP serves as a measure of economic growth and development resulting from investments in the renewable energy sector. Increased FDI in renewable energy projects often leads to the construction of infrastructure, such as solar and wind farms, and the development of related industries, including manufacturing, construction, and services. These investments contribute to GDP growth by boosting economic activity, generating income, and creating employment opportunities (Jakada & Mahmood, 2020). Additionally, expanding renewable energy capacity reduces dependency on costly and polluting fossil fuels, enhances energy security, and frees up resources for other productive uses, further stimulating economic growth (Husnain et al., 2024). In Nigeria, where the renewable energy sector is still emerging, increased FDI can significantly impact GDP by driving investments in clean energy projects, diversifying the economy, and fostering sustainable development (Jayadi & Prasetyo, 2022). Thus, understanding the relationship between FDI, renewable energy, and GDP growth is crucial for policymakers and investors to leverage opportunities for economic advancement while addressing energy and environmental challenges. Foreign Direct Investment (FDI) is crucial in developing renewable energy infrastructure in emerging markets like Nigeria. FDI involves investments by foreign entities in projects, businesses, or assets in a different country. Renewable energy typically includes investments in solar and wind power plants, manufacturing facilities, and research and development initiatives.

In the Nigerian context, FDI in renewable energy contributes to the growth of the sector by providing capital, technology, and expertise that may not be readily available domestically. These investments support the construction of renewable energy projects, such as solar farms and wind turbines, and the development of related industries, including equipment manufacturing, installation, and maintenance services (Vitenu-Sackey, 2020). FDI also facilitates knowledge transfer and technology diffusion, as foreign investors often bring advanced technologies and best practices to the host country, which can help improve efficiency and productivity in the renewable energy sector (Shadab & Alam, 2024). Additionally, FDI inflows can stimulate local entrepreneurship and create job opportunities, contributing to economic growth and development. However, the level of FDI in renewable energy in Nigeria remains relatively low compared to other sectors, partly due to regulatory constraints, policy uncertainties, and infrastructure challenges (Vladucu & Munteanu, 2019). Addressing these barriers is essential to attracting more FDI and unlocking renewable energy's full potential to drive economic growth, energy security, and environmental sustainability in the country. Foreign direct investment (FDI) in Nigeria impacts carbon emis-

sions. The study mentioned in the document found that positive shocks in FDI are positively related to carbon emissions, meaning that an increase in FDI leads to an increase in carbon emissions. This relationship was statistically significant at a level of 1 per cent. On the other hand, adverse shocks in FDI were also positively related to carbon emissions, but the relationship was statistically significant at a level of 5 per cent. This means that a decrease in FDI leads to a decrease in carbon emissions.

Exchange rates significantly influence Foreign Direct Investment (FDI) in renewable energy projects in emerging markets like Nigeria. Exchange rate stability or appreciation can enhance the attractiveness of FDI by reducing currency risk for foreign investors (Cao et al., 2020). A stable or appreciating exchange rate assures investors that the value of their investments will not be eroded due to unfavourable currency movements. This encourages foreign investors to commit capital to renewable energy projects, knowing that their returns will not be significantly affected by fluctuations in the exchange rate. Conversely, exchange rate volatility or depreciation can deter FDI in renewable energy. Fluctuating exchange rates increase uncertainty for investors, making it more difficult to assess the risks and returns of investment projects accurately. This can lead to a decrease in FDI inflows and hinder the development of renewable energy infrastructure. In Nigeria, where exchange rate volatility has been a concern, efforts to stabilize the currency can have positive effects on attracting FDI in renewable energy. Policies aimed at maintaining exchange rate stability, such as effective monetary policy and foreign exchange management, can create a more conducive environment for foreign investors, thereby supporting the growth of the renewable energy sector (Wahyudi & Palupi, 2023). The inflation rate, as it relates to the influence of Foreign Direct Investment (FDI) on renewable energy in emerging markets like Nigeria, can impact investment decisions and project viability. High inflation rates can increase project costs, reduce investor confidence, and decrease the actual returns on investment (Akbulaev, 2023). Inflation erodes currency's purchasing power over time, meaning that the same amount of money will buy fewer goods and services in the future. Inflation can lead to higher equipment, labour, and materials costs in the context of renewable energy projects, making investments less attractive to foreign investors (Morais, 2020). This can result in delays or cancellations of renewable energy projects, hindering the sector's growth and the achievement of energy security and sustainability goals.

Conversely, moderate inflation rates can signal economic growth and stability, which may attract FDI into the renewable energy sector. However, inflation exceeding a certain threshold can deter investment, particularly in long-term projects such as renewable energy infrastructure. Where inflation has been a concern recently, efforts to control inflation and maintain price stability are essential for attracting FDI in renewable energy. Policies that address inflationary pressures and ensure a stable macroeconomic environment can help create favourable

conditions for investment in the sector (Bhuiyan et al., 2022). Unemployment, in the context of FDI in renewable energy in emerging markets like Nigeria, is closely linked to the creation of job opportunities and economic development. Increased FDI in renewable energy projects can create jobs across various sectors, including construction, manufacturing, installation, and maintenance (Zhang et al., 2021). Investments in renewable energy infrastructure require skilled and unskilled labour for project development, construction, and ongoing operations. Expanding the renewable energy sector can reduce unemployment rates by providing job opportunities for local communities (Zhang et al., 2023). This addresses social challenges related to unemployment and enhances the country's overall economic well-being. Furthermore, investments in renewable energy can stimulate innovation and entrepreneurship, creating additional employment opportunities in related industries and services (Sahu & Tiwari, 2024). For instance, the growth of the renewable energy sector may spur the development of research and development facilities, training centres, and consulting firms, further supporting job creation and economic growth. In Nigeria, where unemployment rates remain high, particularly among youth and in rural areas, attracting FDI in renewable energy can be instrumental in addressing this issue (Chowdhury & Anuradha, 2020). However, to fully harness the potential of renewable energy investments to reduce unemployment, policymakers must ensure that supportive policies are in place to encourage investment, facilitate skills development, and promote local content participation in the sector.

Hydropower production, as it relates to the influence of FDI on renewable energy in emerging markets like Nigeria, can significantly impact energy generation, economic growth, and investment opportunities. Nigeria has substantial hydropower potential, with rivers and streams providing opportunities to develop hydroelectric power projects. Foreign investment in hydropower production can lead to the construction of large-scale hydroelectric dams and facilities, which contribute to diversifying the energy mix and reducing dependency on fossil fuels (Carandang et al., 2023). These investments increase the country's energy capacity, create employment opportunities during construction, and promote local economic development in surrounding communities. Furthermore, hydropower projects can attract FDI by offering long-term, reliable returns on investment, particularly in countries with stable regulatory frameworks and favourable investment climates (Azam, 2024). Foreign investors may be attracted to Nigeria's hydropower sector due to its potential for sustained energy production and the opportunity to contribute to its renewable energy goals. However, challenges such as regulatory barriers, environmental concerns, and financing constraints may hinder the development of hydropower projects in Nigeria (Gozgor et al., 2020). Addressing these challenges is crucial to unlocking the full potential of hydropower production and attracting FDI into the sector. Hydropower production presents significant opportunities for FDI in renewable energy in Nigeria, contributing to economic growth, job creation, and sustainable ener-

gy development.

## 2.2. Conceptual Framework

Pursuing sustainable economic growth in emerging markets like Nigeria has led to an increasing emphasis on renewable energy production, with FDI playing a significant role in shaping this transition. Understanding the complex interplay between economic growth, FDI, and various macroeconomic indicators such as GDP, inflation rate, exchange rate, unemployment, and hydropower production is essential for comprehensively assessing the impact of FDI on renewable energy production in Nigeria. The conceptual framework underpins the dimensions of economic growth in emerging markets, specifically focusing on the influence of FDI in renewable energy production in Nigeria. It delves into the interconnectedness of these key economic indicators and their implications for sustainable development and energy security. At the heart of this framework lies GDP, a crucial measure of a country’s overall economic activity and output. In Nigeria’s renewable energy sector, GDP growth reflects the contributions of renewable energy investments to the economy, including job creation, infrastructure development, and industrial expansion (Raziq et al., 2021). The inflation rate, another important indicator, measures the rate at which prices for goods and services rise over time. High inflation rates can erode purchasing power and deter investment, impacting the attractiveness of renewable energy projects (Harun & Afanddi, 2021). Conversely, moderate inflation rates can signal economic growth and stability, fostering a conducive environment for FDI in renewable energy. Exchange rate fluctuations also play a critical role in attracting FDI into renewable energy production in Nigeria. A stable or appreciating exchange rate reduces currency risk for investors, enhancing the attractiveness of renewable energy investments (Raihan et al., 2023). However, exchange rate volatility can create uncertainty and hinder investment flows. Unemployment is another dimension

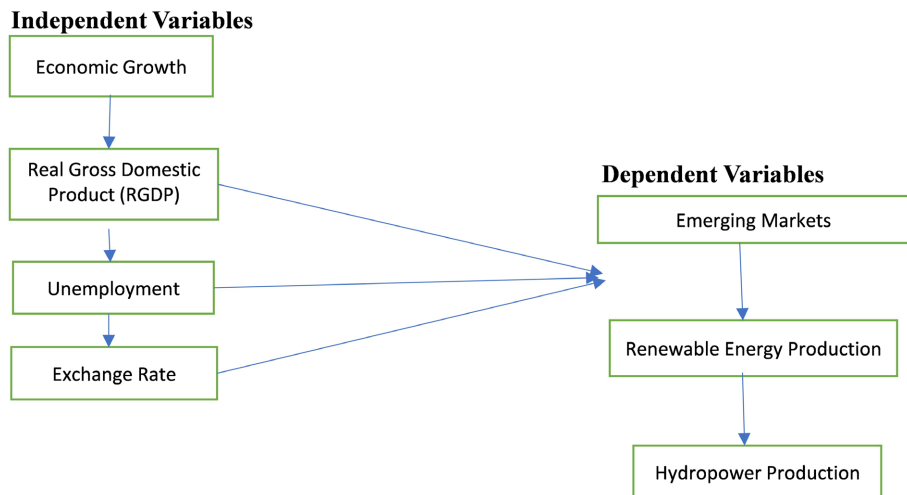

Figure 1. Operationalization of variables. Source: Authors’ Conceptualization (2024).

that influences both economic growth and renewable energy development. FDI in renewable energy projects can create job opportunities, contributing to reduced unemployment rates and socioeconomic development (Rashed et al., 2021b). As a renewable energy source, hydropower production presents unique opportunities and challenges for FDI in Nigeria. Investments in hydropower projects can contribute to energy security, job creation, and economic growth (Nigeria et al. Plan, 2015). However, regulatory hurdles, environmental concerns, and financing constraints may impede the development of hydropower infrastructure (Rashed et al., 2021a) (Figure 1).

### 2.3. Empirical Review of Related Studies

Many empirical studies support theoretical arguments. For example, Jiang et al. (2020) examined spatial spillovers of the effect of FDI for 150 Chinese cities in 2014 and found support for the Pollution Halo Thesis. Similarly, Zakaria and Bibi (2019) investigated the case of South Asian countries from 1984-2015 and reported that FDI adversely affected CO<sub>2</sub> emissions. Similar results are reported by Rehman & Noman (2021) for Pakistan. In a meta-analytic study of the FDI environment relationship, Demena and Afesorgbor (2020) report that FDI significantly reduces environmental emissions. Awan et al. (2023), in a study of 10 emerging countries for 1996-2015, demonstrates that FDI has a positive effect at the 0.05th-0.50th quantiles; however, it is insignificant at higher levels. Edziah et al. (2022), examine the case of 18 SSA countries from 1995 to 2017. The study's results based on Dynamic Common Correlated Effects suggest that machinery imports and renewable energy usage reduce carbon dioxide emissions significantly. However, the effect of the latter is more significant. Although FDI shows a CO<sub>2</sub> emission-reducing effect, it is less pronounced. Kwakwa (2021), investigate the long-run effects of energy use and financial development on emissions in Tunisia using the estimation technique. The study's findings show that primary energy use, energy intensity, electricity consumption and fossil fuel consumption positively affect carbon emission, while combustible renewables and waste and electricity production from natural gas negatively affect carbon emission.

On the other hand, Minh & Van (2023), investigates the FDI - carbon emissions nexus for Vietnam over the period 1990-2015 and reports that FDI hurts the environment. Equally, Wang et al. (2023) examine the case of China based on a dynamic STIRPAT framework and find that FDI is a crucial contributor to CO<sub>2</sub> emissions. In a related study of China, Song et al. (2020) shows that FDI has an overall net positive effect on CO<sub>2</sub> emissions. Duan et al. (2022) also demonstrate a positive effect of FDI on emissions in 28 provinces of China. Singhania and Saini et al. (2022) demonstrate similar effects of FDI on CO<sub>2</sub> emissions for a sample of developed and developing countries that emit high amounts of CO<sub>2</sub> emissions. Using the PMG estimator, Opoku et al. (2022) investigate the relationship between FDI, industrialization, and emissions in 36 African countries

and find that FDI contributes to GHGs. Sarkodie et al. (2024) and Kriebitz and Ammah (2020) report similar results of FDI on emissions in Africa. Similarly, Acheampong et al. (2019), consider the case of SSA countries from 1980-2015 using fixed and random effect estimation techniques. The results show that foreign direct investment and renewable energy contribute to reducing carbon emissions while trade openness deteriorates the environment. It was also found that population growth and financial development contribute to the increase in carbon emissions. Paziienza and De Lucia (2019) consider a sample of 30 OECD nations and demonstrate that FDI contributes to methane emissions, which indicates that FDI contributes to environmental degradation. Gorus and Aslan (2021), have also reported corresponding results for the MENA region. Essandoh et al. (2020), employed the PMG-ARDL estimator to show differential results for the developed and developing countries. The study's results show that FDI was more likely to have adverse and positive effects in low-income and developed countries, respectively. Solarin and Sahu (2023), also report differential effects of FDI, stating that FDI and urbanization contribute to CO<sub>2</sub> emissions in developing countries but have the opposite effect in developed countries. Liu et al. (2022) and Liobikienė and Rimkuvienė (2020), have also demonstrated a neutral effect of FDI on emissions in China and a panel of 147 countries, respectively.

### 3. Research Methodology

#### 3.1. Research Design

The study employed a quantitative research approach which will both be descriptive and explanatory (Muhammed, 2023). The employed quantitative annual data which includes HDP, GDP, INF, UNF, EXR and FDI hydropower production, gross domestic product, inflation rate, unemployment rate, exchange rate and foreign direct investment correspondingly for a period of 54 years triggering 54 observation for the period under review between 1970 and 2023. The research is descriptive as it assesses the trend exhibited by each of the variables for the period under review. The study is explanatory as it seeks to explore the extent to which the FDI and other considered economic factors has impacted hydropower production within the period under review. The study will attempt to bring out the correlation between the variables, as the skewness and kurtosis normality test as well as the Shapiro-Wilk test are done prior to it. Consequently, heterogeneity test, cross dependence test for checking data's cross dependence on each other, as well as the unit root test and co-integration test, and finishing it with structural equation modeling to establishing the structural relationships between the variables. This study is probabilistic rather than deterministic because economic factors in the field of developing nations are influenced by political changes, government regulations and complex human activities meaning that, it is somehow impossible to trigger a purely deterministic causal statement (Muhammed, 2023).

### 3.2. Empirical Model and Data

Based on theoretical and empirical literature on the determinants of economic growth in emerging markets, we specify a model to explain renewable energy production as follows:

$$\text{HDP} = \beta_0 + \beta_1 \text{GDP} + \beta_2 \text{INF} + \beta_3 \text{UNF} + \beta_4 \text{EXR} + \beta_5 \text{FDI} + \varepsilon \quad (1)$$

HDP, GDP, INF, UNF, EXR and FDI hydropower production, gross domestic product, inflation rate, unemployment rate, exchange rate and foreign direct investment correspondingly.

FDI is measured as the net inflows of FDI as a percentage of GDP. Renewable energy consumption is captured by the percentage of renewable energy in total final energy. The uncertainty index captures economic policy uncertainty (EUI). It is an index of the level of policy uncertainty in a country. It is constructed by counts of the word “uncertainty” or variants in the Economist Intelligence Unit (EIU)’s country reports for each year. The word count is then normalised based on the total number of words in the report to produce the index. A higher index represents higher uncertainty for that country. Our study calculates an annual average from the quarterly indices data. Population is measured as the total population. We use the natural log of this variable during estimation.

### 3.3. Estimation Technique

This work used partial least squares-structural equation modeling (PLS-SEM) as its principal method of data analysis, following the approach of [Kissi et al. \(2019\)](#). This approach is appropriate for studying the effects of foreign direct investment (FDI) on renewable energy in developing economies, particularly Nigeria. It enables the analysis of numerous variables at the same time, taking into account their interconnections ([Guenther et al., 2023](#)). SEM is especially valuable in situations when the sample size is somewhat small or when the data includes a moderating variable ([Cheah et al., 2023](#)). In building research, it is crucial to be able to assess multidimensional and challenging constructions. SEM is capable of handling both formative and reflective constructs, making it a valuable tool ([Mohd Ghazali et al., 2023](#)). In addition, PLS-SEM is a versatile methodology that enables researchers to do exploratory research, enabling them to examine ideas and hypotheses without being constrained by predetermined models ([Alshurideh et al., 2020](#)). In this research, the use of PLS-SEM for data analysis may provide a thorough and precise comprehension of the intricate connections among variables inside the framework of building projects. The  $p$ -value was used to determine the outcome of the hypothesis being tested. The hypotheses were accepted if the  $p$ -value was less than the significance threshold of 0.05, and rejected if it was more than 0.05. This approach is recommended by [Cohen \(2019\)](#) and [Kumar et al. \(2023\)](#) for determining the significance of variables using the  $p$ -value. PLSEM is a non-parametric regression analysis ap-

proach that does not need the fulfillment of certain distributional assumptions, as may be necessary in the Ordinary Least Squares (OLS) model.

## 4. Analysis and Results

### 4.1. Descriptive Statistics

The considered variables for the period between 1970 and 2023 which is 54 years containing 54 observations includes the Nigeria GDP growth (annual %), Inflation, consumer prices (annual %), Unemployment rate (%), Official exchange rate (₦/US\$), FDI, net inflows (% of GDP) and Hydropower production which are represented by GDP, INF, UNF, EXR, FDI and HDP respectively in this study. Consequently, according to **Table 1** showing the descriptive statistics for this work, it deduced that the variable with the highest mean EXR with a mean score of 97.41. The variable with the minimal value encompasses the GDP with  $-13.13$  while that with the maximum value is EXR with 425.43 for the period under review. Furthermore, the range entails the highest value of 425.43 from EXR while UNF has the least value of 4.89 for the same variable as the variable with the highest variance us EXR with 14870.052 while the variable with the least value is UNF with 0.707. The Skewness highest and lowest values are entangled in UNF and HDP with 3.621 and  $-0.787$  respectively while Kurtosis has the highest and least values of 14.645 and  $-0.891$  for UNF and HDP correspondingly.

**Table 1.** Descriptive statistics for the variables.

Variables	Range	Minimum	Maximum	Sum	Mean	Variance	Skewness	Kurtosis
EXR	425.43	0.55	425.98	5259.90	97.4056	14870.052	1.285	0.762
HDP	25.21	16.65	41.86	1745.33	32.3209	48.734	$-0.787$	$-0.891$
INF	69.38	3.46	72.84	988.35	18.3028	226.757	2.055	3.811
UNF	4.89	3.51	8.40	222.84	4.1267	0.707	3.621	14.645
GDP	38.14	$-13.13$	25.01	205.26	3.8011	38.009	0.162	2.732
FDI	5.43	$-1.15$	4.28	67.05	1.2417	0.966	0.555	0.683

### 4.2. Normality Test

#### 4.2.1. Skewness and Kurtosis Test for Normality

As to *George and Mallery (2010)*, values within the range of  $-2$  to  $+2$  for both asymmetry and kurtosis are deemed acceptable for demonstrating a normal univariate distribution. *Hair et al. (2011)* and *Demir (2022)* have contended that data is deemed to be normally distributed if its skewness falls within the range of  $-2$  to  $+2$  and its kurtosis falls within the range of  $-7$  to  $+7.14$ . Nevertheless, if the values exceed  $\pm 1.0$ , the skewness or kurtosis of the distribution falls outside the normal range, hence rendering the distribution non-normal. In addition, the normal distribution exhibits a skewness value of zero and a kurtosis value of

three. The test relies on comparing the skewness of the data to zero and the kurtosis of the data to three. The hypothesis of normality is rejected if the  $p$ -value is less than or equal to 0.05. According to **Table 2**, that shows the skewness and kurtosis test for the variables considered in this study, shows that there are deviations in the data as their  $p$ -values are largely less than 0.05.

**Table 2.** Skewness and kurtosis test for normality.

Variable	Obs	Pr (Skewness)	Pr (Kurtosis)	Adj Chi2(2)	Prob > Chi2
gdp	54	0.2491	0.0042	8.28	0.0159
inf	54	0.0000	0.0018	23.81	0.0000
unf	54	0.0000	0.0000	37.44	0.0000
exr	54	0.0005	0.2188	11.09	0.0039
fdi	54	0.0057	0.1252	8.60	0.0135
hdp	54	0.0176	0.0456	8.36	0.0153

#### 4.2.2. Shapiro-Wilk Test for Normal Data

The Shapiro-Wilk test is a statistical hypothesis test used to assess whether a given sample is drawn from a normal distribution. If the  $p$ -value is small, we can reject the null hypothesis and conclude that the sample does not come from a normal distribution (Wang et al., 2023). As indicated in **Table 3**, the Shapiro-Wilk test for normal data indicates the data are not generated for normal sources.

**Table 3.** Shapiro-Wilk test for normal data

Variable	Obs	W	V	Z	Prob > z
gdp	54	0.94617	2.690	2.120	0.01700
inf	54	0.73230	13.379	5.556	0.00000
unf	54	0.72402	13.793	5.622	0.00000
exr	54	0.94272	2.863	2.253	0.01212
fdi	54	0.80372	9.810	4.892	0.00000
hdp	54	0.84792	7.601	4.345	0.00001

#### 4.3. Result of Pearson Correlation

The Pearson correlation test is employed to ascertain the presence of a positive or negative correlation between a dependent variable and an independent variable. The findings are depicted in **Table 4**, which indicates that HDP have negative relationship with GDP, UNF and EXR with a correlation coefficient of  $-0.0407$ ,  $-0.4269$  and  $-0.7559$  respectively while it equally has a positive relationship with INF and FDI with a correlation coefficient of  $0.2480$  and  $0.1077$  correspondingly.

**Table 4.** Pearson correlation.

Dependent Variables	Independent Variables	GDP	INF	UNF	FDI	EXR
HDP		-0.0407	0.2480	-0.4269	0.1077	-0.7559

#### 4.4. Time Series Test

##### 4.4.1. Slope Heterogeneity Test

Another test for heterogeneity is employed to determine whether the coefficients' slope is homogeneous or heterogeneous (Naifar, 2023). Table 5 displays the outcomes of the slope heterogeneity test devised by (Blomquist & Westerlund, 2013). Based on the results, the coefficients are not uniform, and the *p*-values are statistically significant at the 5% level. Consequently, the null hypothesis regarding the slope coefficient is rejected, and the alternative hypothesis of slope heterogeneity is employed.

**Table 5.** Pearson correlation.

	Delta	<i>p</i> -Value
Delta	-2.576	0.000
Delta <sub>adj</sub>	-2.978	0.000

##### 4.4.2. Cross-Sectional Dependence Test (CSDT)

The subsequent stage in panel data econometrics involves doing a test for cross-sectional dependence. The outcomes of the CSDT model suggested by Pesaran et al. (2004), can be found in Table 6. The results suggest that all factors' *p*-values are extremely significant, indicating that variables such as GDP, INF, UNF, EXR, FDI and HDI all exhibit the presence of CSD (Azam, 2024).

**Table 6.** CDST.

Variables	<i>p</i> -Value
GDP	(4.229) 0.000
INF	(9.715) 0.000
UNF	(22.19) 0.000
EXR	(18.80) 0.000
FDI	(23.28) 0.000
HDP	(10.11) 0.000

##### 4.4.3. Unit Root Test

Conducting analysis using time series data necessitates the data being stable, as non-stationary data might result in inaccurate conclusions. The unit root test is used to determine the stationarity of data using the Augmented Dickey-Fuller (ADF) and Phillips Perron (PP) tests (Zakaria & Bibi, 2019). Table 7 displays the

outcomes of the Augmented Dickey-Fuller test and Phillips Perron test for both the original data and the differenced data. In order to establish a long-term link between variables, it is necessary for the series to not have a unit root. The test is conducted at a specified level utilizing the first difference method, with a significance level of 5% based on the Mackinnon Critical value (Minh & Van, 2023).

**Table 7.** Results of ADF Test & PP at level and first difference.

ADF AT LEVEL					
Variables	Z-Statistics	Lag Order	P-Value	Alterlocal Hypothesis	Remark
GDP	-6.034	0	0.0000	Stationary	Stationary
INF	-3.560	0	0.0066	Stationary	Stationary
UNF	-2.780	0	0.0613	Stationary	Not Stationary
EXR	2.178	0	0.9989	Stationary	Not Stationary
FDI	-4.104	0	0.0010	Stationary	Stationary
HDP	-1.120	0	0.7069	Stationary	Not Stationary
PP TEST AT LEVEL					
GDP	-37.866	0	0.0000	Stationary	Stationary
INF	-20.544	0	0.0075	Stationary	Stationary
UNF	-14.349	0	0.0562	Stationary	Not Stationary
EXR	2.434	0	0.9989	Stationary	Not Stationary
FDI	-26.980	0	0.0009	Stationary	Stationary
HDP	-2.512	0	0.7300	Stationary	Not Stationary
ADF AT FIRST DIFFERENCE					
Variables	T-Statistics	Lag Order	P-Value	Alterlocal Hypothesis	Remark
UNF	-2.428	3	0.0341	Stationary	Stationary
EXR	1.656	3	0.0080	Stationary	Stationary
HDP	-0.917	3	0.0024	Stationary	Stationary
PP TEST AT FIRST DIFFERENCE					
UNF	-14.349	3	0.0062	Stationary	Stationary
EXR	2.434	3	0.0089	Stationary	Stationary
HDP	-2.512	3	0.0030	Stationary	Stationary

**Source:** Researcher's Computation (R-Programming) (2023).

The ADF and PP test results shows that all the variables such as GDP, INF and FDI are stationary at level while UNF, EXR and HDP were not stationary at levels, as their absolute value of their respective t-statistics values are more than the absolute 0.5% critical value in both tests. However, after testing them at their first difference they were all stationary as all the variables are integrated of the

same order of 3 (Muhammed, 2023). Therefore, the Co-integration test is necessary to further check for the long run relationship among the variables (Iwegbu, & Nwarawgwy, 2019).

#### 4.4.4. Co-Integration Test (CiT)

The application CiT to this study is the Johansen co-integration test as applied in many studies including Muhammed (2023) and Azam (2024). Table 8 confirms the acceptance of the alternative hypothesis and the rejection of the null hypothesis of no co-integration. This implies that the variables are co-integrated and have a long-term relationship.

**Table 8.** Johansen CiT.

Hypotheses	Johansen CiT	Prob.	Max-Eigen Test	Prob.
None	23.17	0.0001	19.12	0.0000
At most 1	65.55	0.0028	59.65	0.0000
At most 2	151.24	0.0015	116.27	0.0512
At most 3	24.12	0.0086	22.64	0.0115
At most 4	27.45	0.021	25.38	0.0169
At most 5	22.17	0.416	17.29	0.521
At most 6	54.12	0.0171	52.15	0.0211

#### 4.5. Structural Equation Modeling (SEM)

The SEM as indicated in Table 9 shows the structural relationship between the considered variables where the independent variables include the Gross Domestic Product (GDP), inflation rate (INF), unemployment rate (UNF) and exchange rate (EXR), the dependent variable comprises of the output of hydro-power production (HDP) while the moderating variable is the foreign direct investment net inflow (FDI). Consequently, according to the outcome, with a coefficient of  $-0.245$  and a Pr (0.827), it first posits the rejection of the null hypothesis and indicates that the GDP does not have any significant impact on the HDP as its existence does not depend on the GDP which is likewise can be posited to be a negative predictor of the variable HDP. Also, with regression coefficient of  $0.0609$  and a Pr (1.40) for INF delineates the rejection of the null hypothesis and shows that it can be considered as a positive predictor of HDP but does not equally have effect on the downward and upward productivity level of the HDP. For UNF, the presence of a negative regressor is also experienced with a regression coefficient of  $-0.655$  and Pr (0.390) equally depicts the rejection of the null hypothesis indicating that there is no significant impact despite the fact that it can be considered a negative predictor of HDP. Similarly, for the EXR, having a regressor value of  $-0.040$  and a Pr (0.000) indicates the rejection of the null hypothesis emphasizing that the EXR has a significant impact on HDP despite it negative coefficient making it to be considered as a negative predictor of the va-

riable. Furthermore, the FDI regression coefficient  $-0.523$  with a Pr (0.458) indicating a likewise rejection in the null hypothesis while been a negative predictor of HDP. As a result, the regression line entails  $HDP = 37.55 - 6.59 (EXR)$  as the only variable with a significant impact on the HDP.

**Table 9.** SEM.

Observed: gdp inf unf exr fdi						
Fitting target model:						
Iteration 0: log likelihood = $-1019.6436$						
Iteration 1: log likelihood = $-1019.6436$						
Structural equation model Number of Obs = 54						
Estimation method = ml						
Log likelihood = $-1019.6436$						
	Coef.	OIM Std. Err	z	P > z	[95% Conf. Interval	
Structural hdp < -						
Gdp	$-0.245322$	0.112449	$-0.22$	0.827	$-0.2449283$	0.195864
inf	0.0609472	0.043568	1.40	0.162	0.0244444	0.1463389
unf	$-0.654614$	0.7615472	$-0.86$	0.390	$-2.147219$	0.8379912
exr	$-0.040318$	0.0061168	$-6.59$	0.000	$-0.523066$	$-0.0283293$
fdi	$-0.5215134$	0.7021144	$-0.74$	0.458	$-1.897632$	0.8546054
_cons	37.5519	2.715578	13.83	0.000	32.22875	42.87362
Variance						
e.hp	19.84881	3.819906			13.61196	28.94332

LR test of model vs saturated:  $\chi^2(0) = 0.00$ , Prob > chi.

Renewable energy is widely seen as a practical remedy for numerous socio-economic and environmental issues worldwide (Rahman & Sultana, 2022; Nguyen & Kakinaka, 2019). Therefore, the shift from traditional and finite energy sources such as coal, oil, and natural gas to sustainable and renewable energy sources like solar, hydropower, geothermal, and wind is now unavoidable in order to achieve a world that is both environmentally sustainable and free from the impacts of climate change (Wang et al., 2022). In 2018, renewables accounted for only 2% of Africa's total primary energy demand, according to the International Energy Agency (IEA, 2022). IRENA (2021) outlines seven key factors that can expedite the energy transition in Africa. These factors include: implementing tariffs that accurately reflect costs and ensuring sustainable service provision, creating a favorable investment environment for renewable energy, establishing effective structures and technologies for energy efficiency, developing a robust regulatory framework, fostering innovative business models, strengthening power grids, and neutralizing the current capacity of fossil fuel generation. The determinants of transition towards clean energy are FDI, financial development, institutional quality, and human capital (Alsagr & van Hemmen, 2021; Zakaria

& Bibi, 2019). These elements play a significant role in emphasizing the shift towards clean energy. Renewable energy has the potential to enhance energy security and accessibility, foster a sustainable environment, and drive sustainable economic growth (Wang et al., 2023). However, this study agrees that the FDI have not been significant in the generation of hydropower in the country like the other economic factors of inflation rate, unemployment rate and foreign direct investment except for the exchange rate that has a significant impact on it. This means that only the exchange rate has influenced the generation of hydropower in Nigeria which can be ascribed to the sharing of power by the country with the other neighboring countries including but not limited to Niger Republic, Benin Republic and Chad. It also states that despite the consideration of inflation rate importance to the growth of Nigeria it has no effect on the hydropower production in Nigeria which is against the findings of Sekwati and Dagume (2023), Iqbal et al. (2022), Khan et al. (2023), Nadilla and Ichsan (2023), and Ayele et al. (2023) that finds inflation to play a crucial role in determining the long-term economic growth of Latin America.

As delineated in **Figure 1**, it shows that while there is increasing impact of the exchange rate on the generation of the hydropower in Nigeria, which is directly links, other macroeconomic factors such as inflation, unemployment rate and FDI have surprisingly have no impact on the generation of hydropower in the country over the years. However, this study's findings on FDI corroborates with previous studies that posits that the renewable energy has been the major beneficiary from FDI. For example, Doytch and Narayan (2016), discovered that an escalation in foreign direct investment (FDI) inflows resulted in an upsurge in renewable energy consumption, but only in high-income nations. Nevertheless, Elheddad et al. (2022), investigated the influence of foreign direct investment (FDI) on the consumption of renewable energy in the context of Bangladesh, and revealed a positive correlation between foreign direct investment (FDI) and non-renewable energy use, as well as a negative correlation between FDI and renewable energy consumption. Akintande et al. (2020), found that there was no statistically significant effect of increased foreign direct investment (FDI) inflows on the usage of renewable energy in the five most populous African countries. The finding of Amoako and Insaiddoo (2021), indicated that foreign direct investment (FDI) inflows did not have a substantial effect on energy consumption in Ghana. Several researches have shown a positive correlation between an increase in foreign direct investment (FDI) inflows and a growth in renewable energy consumption. This relationship is attributed to the transfer of clean energy technology. The studies conducted by Shahbaz et al. (2022), Doğan et al. (2022), Zhang et al. (2021), and Kang et al. (2021) support this finding. Therefore, there is a lack of agreement regarding the role of foreign direct investment (FDI) in the consumption of renewable energy in the existing body of research. Overall, this study disagrees and agrees with some studies that the size, method, and content of inflation, unemployment and foreign direct investment do not

have a significant influence (Figure 2).

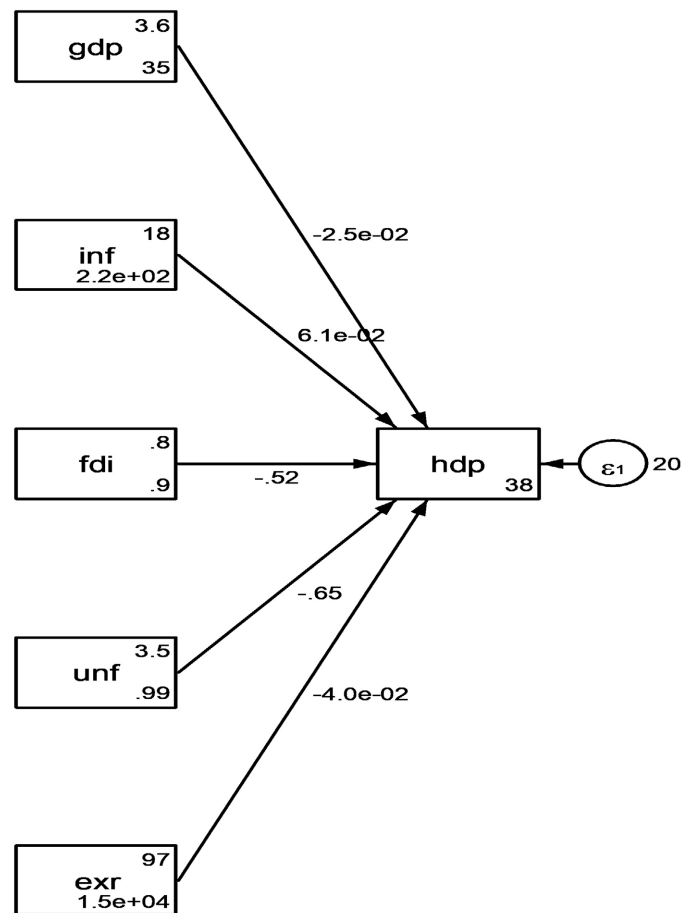

Figure 2. Structure of the relationship.

## 5. Conclusion and Recommendations

The test results indicate that certain variables exhibit unit root problems and that the variables are integrated at different orders. It is crucial to conduct a test to determine the presence of cointegration or a long-term equilibrium relationship between the variables when the unit root is detected. The SEM is adopted for this study's objective and shows that only exchange rate has structural relationship with hydropower production in Nigeria while the other economic factors of inflation, unemployment and FDI do not historically have impact on the level of hydropower production in Nigeria. Therefore, it is necessary to prioritize efforts to attract reduced exchange rates through the balancing of balance of payment and enhancing the quality of institutions. Additionally, increasing local investment in the economy is also essential as the results also suggest that exchange rate has a negative impact on the hydropower production of the country. This study thus, recommends that:

1) Controlling the rate of exchange rate is crucial for maintaining hydropower production growth. Failure to do so might lead to a decrease in the productive

capacity in hydropower.

2) Nigeria can benefit from increased regional and global collaboration, which includes trade agreements and cross-border infrastructure efforts that enhance connectivity and promote economic integration.

3) Political stability enables the strategic and systematic implementation of infrastructure development, which is vital for fostering economic growth through enhanced connectivity, reduced transaction costs, and overall improvement.

4) Policymakers should persist in prioritizing inclusive growth methods aimed at reducing income inequality and improving living standards for all segments of society.

5) Promoting domestic investment is crucial. Ensuring a favorable climate for businesses, ensuring easy access to financial resources, and fostering innovation are essential measures for boosting the growth of local capital.

### Conflicts of Interest

The authors declare no conflicts of interest regarding the publication of this paper.

### References

- Abdi, A. H., Zaidi, M. A. S., Halane, D. R., & Warsame, A. A. (2024). Asymmetric Effects of Foreign Direct Investment and Trade Openness on Economic Growth in Somalia: Evidence from a Non-Linear ARDL Approach. *Cogent Economics & Finance*, 12, Article ID: 2305010. <https://doi.org/10.1080/23322039.2024.2305010>
- Acheampong, A. O., Adams, S., & Boateng, E. (2019). Do Globalization and Renewable Energy Contribute to Carbon Emissions Mitigation in Sub-Saharan Africa? *Science of the Total Environment*, 677, 436-446. <https://doi.org/10.1016/j.scitotenv.2019.04.353>
- Adewole, J. A., Kadiri, K. I., Afolabi, C. S., & Kayode, O. J. (2023). Financial Risk Management and Shareholders Wealth Maximization in Nigerian Deposit Money Banks. *Fuoye Journal of Management, Innovation and Entrepreneurship*, 2, 106-115.
- Akbulaev, N. (2023). Analysis of Renewable Energy, Foreign Direct Investment, and CO<sub>2</sub> Relationship: Evidence from France, Germany, and Italy. *International Journal of Energy Economics and Policy*, 13, 645-657. <https://doi.org/10.32479/ijeep.14365>
- Akintande, O. J., Olubusoye, O. E., Adenikinju, A. F., & Olanrewaju, B. T. (2020). Modeling the Determinants of Renewable Energy Consumption: Evidence from the Five Most Populous Nations in Africa. *Energy*, 206, Article ID: 117992. <https://doi.org/10.1016/j.energy.2020.117992>
- Alsagr, N., & van Hemmen, S. (2021). The Impact of Financial Development and Geopolitical Risk on Renewable Energy Consumption: Evidence from Emerging Markets. *Environmental Science and Pollution Research*, 28, 25906-25919. <https://doi.org/10.1007/s11356-021-12447-2>
- Alshurideh, M., Al Kurdi, B., Salloum, S. A., Arpaci, I., & Al-Emran, M. (2020). Predicting the Actual Use of M-Learning Systems: A Comparative Approach Using PLS-SEM and Machine Learning Algorithms. *Interactive Learning Environments*, 31, 1214-1228. <https://doi.org/10.1080/10494820.2020.1826982>
- Amin, A., Anwar, S., & Liu, X. (2020). Outward Foreign Direct Investment and Economic Growth in Romania: Evidence from Non-Linear ARDL Approach. *International Jour-*

- nal of Finance & Economics*, 27, 665-677. <https://doi.org/10.1002/ijfe.2173>
- Amoako, S., & Insaiddoo, M. (2021). Symmetric Impact of FDI on Energy Consumption: Evidence from Ghana. *Energy*, 223, Article ID: 120005. <https://doi.org/10.1016/j.energy.2021.120005>
- Awan, A., Rahman, S. U., Ali, M., & Zafar, M. (2023). Institutional Performance and Tourism Arrival Nexus in BRICS Countries: Evidence from Nonlinear ARDL Cointegration Approach. *iRASD Journal of Economics*, 5, 784-796. <https://doi.org/10.52131/joe.2023.0501.0116>
- Ayele, A., Mitiku, F., & Bayissa, M. (2023). Impact of Inflation and Unemployment on Economic Growth in Ethiopia (1991-2020). *Journal of Somali Studies*, 10, 97-116. <https://doi.org/10.31920/2056-5682/2023/v10n2a5>
- Azam, A. (2024). How Environmental Policy Stringency, Foreign Direct Investment, and Eco-Innovation Supplement the Energy Transition: New Evidence from NICS. *Sustainability*, 16, Article No. 3033. <https://doi.org/10.3390/su16073033>
- Bhuiyan, M. A., Zhang, Q., Khare, V., Mikhaylov, A., Pinter, G., & Huang, X. (2022). Renewable Energy Consumption and Economic Growth Nexus—A Systematic Literature Review. *Frontiers in Environmental Science*, 10, Article ID: 878394. <https://doi.org/10.3389/fenvs.2022.878394>
- Blomquist, J., & Westerlund, J. (2013). Testing Slope Homogeneity in Large Panels with Serial Correlation. *Economics Letters*, 121, 374-378. <https://doi.org/10.1016/j.econlet.2013.09.012>
- Bui Minh, T., & Bui Van, H. (2023). Evaluating the Relationship between Renewable Energy Consumption and Economic Growth in Vietnam, 1995-2019. *Energy Reports*, 9, 609-617. <https://doi.org/10.1016/j.egyr.2022.11.074>
- Cao, W., Chen, S., & Huang, Z. (2020). Does Foreign Direct Investment Impact Energy Intensity? Evidence from Developing Countries. *Mathematical Problems in Engineering*, 2020, Article ID: 5695684. <https://doi.org/10.1155/2020/5695684>
- Carandang, D. C. O., De Castro, A. R. V., & Cabautan, R. R. (2023). Impact of Investments and Renewable Energy Consumption on the Economic Growth of ASEAN-5. *International Journal of Research in Engineering, Science and Management*, 6, 107-114.
- Cheah, J., Amaro, S., & Roldán, J. L. (2023). Multigroup Analysis of More than Two Groups in PLS-SEM: A Review, Illustration, and Recommendations. *Journal of Business Research*, 156, Article ID: 113539. <https://doi.org/10.1016/j.jbusres.2022.113539>
- Chowdhury, P. R., & Anuradha, A. (2020). Foreign Direct Investment and Economic Growth: Two Equally Desirable Dilemmas of Policy Makers in India. *International Journal of Management*, 11, 903-915. <https://doi.org/10.34218/ijm.11.9.2020.083>
- Cohen, B. J. (2019). *Advanced Introduction to International Political Economy*. Edward Elgar Publishing.
- Demena, B. A., & Afesorghor, S. K. (2020). The Effect of FDI on Environmental Emissions: Evidence from a Meta-Analysis. *Energy Policy*, 138, Article ID: 111192. <https://doi.org/10.1016/j.enpol.2019.111192>
- Demir, S. (2022). Comparison of Normality Tests in Terms of Sample Sizes under Different Skewness and Kurtosis Coefficients. *International Journal of Assessment Tools in Education*, 9, 397-409. <https://doi.org/10.21449/ijate.1101295>
- Doğan, B., Radulescu, M., Shahzad, U., & Saboori, B., (2022). Import Product Diversification and Renewable Energy: A New Appraisal from Developed and Developing Countries. *Energy Sources, Part B: Economics, Planning, and Policy*, 17, Article ID: 2038733.

- Doytch, N., & Narayan, S. (2016). Does FDI Influence Renewable Energy Consumption? An Analysis of Sectoral FDI Impact on Renewable and Non-Renewable Industrial Energy Consumption. *Energy Economics*, 54, 291-301.  
<https://doi.org/10.1016/j.eneco.2015.12.010>
- Duan, W., David Madasi, J., & Khurshid, A. (2022). How Network Structure and Exchange Rate Volatility Drive the Industrial Ecosystem towards Collapse: A Global Perspective. *Economic Research-Ekonomika Istraživanja*, 36, 1688-1707.  
<https://doi.org/10.1080/1331677x.2022.2092524>
- Edziah, B. K., Sun, H., Adom, P. K., Wang, F., & Agyemang, A. O. (2022). The Role of Exogenous Technological Factors and Renewable Energy in Carbon Dioxide Emission Reduction in Sub-Saharan Africa. *Renewable Energy*, 196, 1418-1428.  
<https://doi.org/10.1016/j.renene.2022.06.130>
- Elheddad, M., Alfar, A. J. K., Haloub, R., Sharma, N., & Gomes, P. (2022). The Impact of Foreign Direct Investment (FDI) on Renewable and Non-Renewable Energy in Bangladesh: Does the Global Climate Change Emergencies Required? *International Journal of Emergency Services*, 11, 409-421. <https://doi.org/10.1108/ijes-12-2021-0083>
- Encinas-Ferrer, C., & Villegas-Zermeño, E. (2015). Foreign Direct Investment and Gross Domestic Product Growth. *Procedia Economics and Finance*, 24, 198-207.  
[https://doi.org/10.1016/s2212-5671\(15\)00647-4](https://doi.org/10.1016/s2212-5671(15)00647-4)
- Essandoh, O. K., Islam, M., & Kakinaka, M. (2020). Linking International Trade and Foreign Direct Investment to CO<sub>2</sub> Emissions: Any Differences between Developed and Developing Countries? *Science of the Total Environment*, 712, Article ID: 136437.  
<https://doi.org/10.1016/j.scitotenv.2019.136437>
- George, D., & Mallery, P. (2010). *IBM SPSS Statistics 26 Step by Step: A Simple Guide and Reference*. Routledge.
- Gorus, M. S., & Ben Ali, M. S. (2021). Do Governance Indicators Predict Inequality? A Panel Non-Causality Framework for the Emerging Countries. In *Governance in the Developing World: Transnational Insights on Economic Development* (pp. 43-59). Springer Nature.
- Gozgor, G., Mahalik, M. K., Demir, E., & Padhan, H. (2020). The Impact of Economic Globalization on Renewable Energy in the OECD Countries. *Energy Policy*, 139, Article ID: 111365. <https://doi.org/10.1016/j.enpol.2020.111365>
- Guenther, P., Guenther, M., Ringle, C. M., Zaefarian, G., & Cartwright, S. (2023). Improving PLS-SEM Use for Business Marketing Research. *Industrial Marketing Management*, 111, 127-142. <https://doi.org/10.1016/j.indmarman.2023.03.010>
- Hair, J. F., Sarstedt, M., Ringle, C. M., & Mena, J. A. (2011). An Assessment of the Use of Partial Least Squares Structural Equation Modeling in Marketing Research. *Journal of the Academy of Marketing Science*, 40, 414-433.  
<https://doi.org/10.1007/s11747-011-0261-6>
- Harun, N. H., & Afanddi, D. N. M. (2021). Investigating the Relationship between Gross Domestic Product, Foreign Direct Investment, Renewable Energy Consumption and Stock Market Performance in Malaysia. *Global Business and Management Research*, 13, 777-788.
- Hassan Jakada, A., & Mahmood, S. (2020). An Asymmetric Effect of Economic Growth, Foreign Direct Investment and Financial Development on the Quality of Environment in Nigeria. *The Journal of Management Theory and Practice (JMTP)*, 1, 5-13.  
<https://doi.org/10.37231/jmtp.2020.1.1.6>
- Husnain, M. A., Guo, P., Pan, G., & Manjang, M. (2024). Unveiling the Interplay of In-

- stitutional Quality, Foreign Direct Investment, Inflation and Domestic Investment on Economic Growth: Empirical Evidence for Latin America. *International Journal of Economics and Financial Issues*, 14, 85-94. <https://doi.org/10.32479/ijefi.15580>
- Ibrahiem, D. M. (2015). Renewable Electricity Consumption, Foreign Direct Investment and Economic Growth in Egypt: An ARDL Approach. *Procedia Economics and Finance*, 30, 313-323. [https://doi.org/10.1016/s2212-5671\(15\)01299-x](https://doi.org/10.1016/s2212-5671(15)01299-x)
- IEA (2022). *Africa Energy Outlook 2022*. IEA. <https://www.iea.org/reports/africa-energy-outlook-2022>
- Iqbal, K., Sarfraz, M., & Khurshid, (2022). Exploring the Role of Information Communication Technology, Trade, and Foreign Direct Investment to Promote Sustainable Economic Growth: Evidence from Belt and Road Initiative Economies. *Sustainable Development*, 31, 1526-1535. <https://doi.org/10.1002/sd.2464>
- IRENA, F. (2021). Renewable Energy for Agri-Food Systems: Towards the Sustainable Development Goals and the Paris Agreement.
- Iwegbu, O., & Nwarawgwy I. C. (2019). Effect of Exchange Rate Shock on Key Sectors of the Nigerian Economy. In *Leading Issues in Macroeconomic Stabilisation and Financial Development, a Festschrift in Honour of Professor Oluwatayo Fakivesi* (pp. 507-533). Unilag Press & Bookshop Ltd.
- Jayadi, A., & Prasetyo, S.B. (2022). An Analysis of the Influence of Foreign Direct Investment on Emerging Market Economies Growth. *Journal of Developing Economies*, 7, 309-327. <https://doi.org/10.20473/jde.v7i2.40421>
- John, B. E., Lawal, M. T., Yaw, O., Danso-Mireku, O., & Mahesh, M. (2023). Remittance and Economic Growth; Evidence from West Africa. *EXCEL International Journal of Multidisciplinary Management Studies*, 5, 73-83.
- Kang, X., Khan, F. U., Ullah, R., Arif, M., Rehman, S. U., & Ullah, F. (2021). Does Foreign Direct Investment Influence Renewable Energy Consumption? Empirical Evidence from South Asian Countries. *Energies*, 14, Article No. 3470. <https://doi.org/10.3390/en14123470>
- Khan, H., Dong, Y., Bibi, R., & Khan, I. (2023). Institutional Quality and Foreign Direct Investment: Global Evidence. *Journal of the Knowledge Economy*. <https://doi.org/10.1007/s13132-023-01508-1>
- Kissi, E., Asare, O. A., Agyekum, K., Yamoah Agyemang, D., & Labaran, M. (2019). Ascertaining the Interaction Effects among Organisational Citizenship Behaviour, Work Overload and Employees' Performance in the Ghanaian Construction Industry. *International Journal of Productivity and Performance Management*, 68, 1235-1249. <https://doi.org/10.1108/ijppm-07-2018-0262>
- Kriebitz, A., & Ammah, L. (2020). Statistical Capacity, Human Rights and FDI in Sub-Saharan Africa Patterns of FDI Attraction in Sub-Saharan Africa. *Journal of Management and Sustainability*, 10, 162-173. <https://doi.org/10.5539/jms.v10n1p162>
- Kumar, A., Nagi, M., Kumar, M., & Kaur, M. D. (2023). Is There a Need of Providing at Least 3 Decimal *p*-Value to Avoid Type 1 Error in a Clinical Research? *Interdisciplinary CardioVascular and Thoracic Surgery*, 36, ivac293. <https://doi.org/10.1093/icvts/ivac293>
- Kwakwa, P. A. (2021). The Effects of Natural Resource Extraction and Renewable Energy Consumption on Carbon Dioxide Emissions in Sub-Saharan Africa. *The Journal of Energy and Development*, 47, 195-222.
- Liobikienė, G., & Rimkuvienė, D. (2020). The Role of Income Inequality on Consumption-Based Greenhouse Gas Emissions under Different Stages of Economic Develop-

- ment. *Environmental Science and Pollution Research*, 27, 43067-43076. <https://doi.org/10.1007/s11356-020-10244-x>
- Liu, X., Zhang, W., Liu, X., & Li, H. (2022). The Impact Assessment of FDI on Industrial Green Competitiveness in China: Based on the Perspective of FDI Heterogeneity. *Environmental Impact Assessment Review*, 93, Article ID: 106720. <https://doi.org/10.1016/j.eiar.2021.106720>
- Mohd Ghazali, Z., Wan Yaacob, W. F., & Wan Omar, W. M. (2023). LGCM and PLS-SEM in Panel Survey Data: A Systematic Review and Bibliometric Analysis. *Data*, 8, Article No. 32. <https://doi.org/10.3390/data8020032>
- Morais, A. P. A. (2020). *The Role of European Emerging Markets in Europe's Transition to Renewable Energy: A Managerial Outlook of the Cases of Bulgaria and Romania*.
- Muhammed, A. O. (2023). *Exchange Rate Volatility and Material Prices of Selected Building Materials in North-Central Nigeria Projects*. Thesis, Federal University of Technology.
- Nadilla, R., & Ichsan, I. (2023). The Effect of Inflation, Labor Force Participation Rate and Exports on Economic Growth in Indonesia. *Journal of Malikussaleh Public Economics*, 6, 20. <https://doi.org/10.29103/jmpe.v6i2.13754>
- Naifar, N. (2023). Does Climate Change Affect Sovereign Credit Risk? International Evidence. *Borsa Istanbul Review*, 23, S84-S95. <https://doi.org/10.1016/j.bir.2023.10.001>
- Nguyen, K. H., & Kakinaka, M. (2019). Renewable Energy Consumption, Carbon Emissions, and Development Stages: Some Evidence from Panel Cointegration Analysis. *Renewable Energy*, 132, 1049-1057. <https://doi.org/10.1016/j.renene.2018.08.069>
- Opoku, E. E. O., Acheampong, A. O., Dzator, J., & Kufuor, N. K. (2022). Does Environmental Sustainability Attract Foreign Investment? Evidence from Developing Countries. *Business Strategy and the Environment*, 31, 3542-3573.
- Pazienza, P., & De Lucia, C. (2019). How Does FDI in the "Agricultural and Fishing" Sector Affect Methane Emission? Evidence from the OECD Countries. *Economia Politica*, 37, 441-462. <https://doi.org/10.1007/s40888-019-00168-2>
- Pesaran, M. H., Schuermann, T., & Weiner, S. M. (2004). Modeling Regional Interdependencies Using a Global Error-Correcting Macroeconometric Model. *Journal of Business & Economic Statistics*, 22, 129-162. <https://doi.org/10.1198/073500104000000019>
- Ptacek, O., Kaderabkova, B., & Piecha, M. (2015). Venture Capital, Private Equity and Foreign Direct Investment: Case Study of the Czech Republic. *Procedia Economics and Finance*, 30, 680-689. [https://doi.org/10.1016/s2212-5671\(15\)01317-9](https://doi.org/10.1016/s2212-5671(15)01317-9)
- Rahman, M. M., & Sultana, N. (2022). Impacts of Institutional Quality, Economic Growth, and Exports on Renewable Energy: Emerging Countries Perspective. *Renewable Energy*, 189, 938-951. <https://doi.org/10.1016/j.renene.2022.03.034>
- Raihan, A., Voumik, L. C., Rahman, M. H., & Esquivias, M. A. (2023). Unraveling the Interplay between Globalization, Financial Development, Economic Growth, Greenhouse Gases, Human Capital, and Renewable Energy Uptake in Indonesia: Multiple Econometric Approaches. *Environmental Science and Pollution Research*, 30, 119117-119133. <https://doi.org/10.1007/s11356-023-30552-2>
- Rashed, A., Yong, C., & Soon, S. (2021a). Determinants of Foreign Direct Investment in Renewable Electricity Industry in Africa. *International Journal of Sustainable Energy*, 41, 980-1004. <https://doi.org/10.1080/14786451.2021.2016763>
- Rashed, A., Yong, C., & Soon, S. (2021b). The Nexus among Foreign Direct Investment in Renewable Electricity Industry, Renewable Electricity Production, and Economic Growth in Africa. *Cogent Economics & Finance*, 10, Article ID: 2001141. <https://doi.org/10.1080/23322039.2021.2001141>

- Raziq, M. M., Benito, G. R. G., & Ahmad, M. (2021). Institutional Distance and MNE-Subsidiary Initiative Collaboration: The Role of Dual Embeddedness. *European Management Review*, 18, 311-328. <https://doi.org/10.1111/emre.12454>
- Rehman, F. U., & Noman, A. A. (2021). China's Outward Foreign Direct Investment and Bilateral Export Sophistication: A Cross Countries Panel Data Analysis. *China Finance Review International*, 12, 180-197. <https://doi.org/10.1108/cfri-04-2020-0040>
- Sahu, P., & Tiwari, M. (2024). Foreign Direct Investment for Developing Countries. *International Journal of Innovative Research in Technology and Science*, 12, 107-115.
- Saini, V., Singal, S. K., & Saini, R. P. (2022). Renewable Energy-Based System for Electrification of Remote Villages. In *2022 International Conference on Green Energy, Computing and Sustainable Technology (GECOST)* (pp. 6-10). Institute of Electrical and Electronics Engineers. <https://doi.org/10.1109/gecost55694.2022.10010609>
- Sarkodie, S. A., Owusu, P. A., & Taden, J. (2024). Green Growth Assessment across 203 Economies: Trends and Insights. *Sustainable Horizons*, 10, Article ID: 100083. <https://doi.org/10.1016/j.horiz.2023.100083>
- Sekwati, D., & Dagume, M. A. (2023). Effect of Unemployment and Inflation on Economic Growth in South Africa. *International Journal of Economics and Financial Issues*, 13, 35-45. <https://doi.org/10.32479/ijefi.13447>
- Shadab, S., & Alam, F. (2024). High-Technology Exports, Foreign Direct Investment, Renewable Energy Consumption and Economic Growth: Evidence from the United Arab Emirates. *International Journal of Energy Economics and Policy*, 14, 394-401. <https://doi.org/10.32479/ijeep.15188>
- Shahbaz, M., Sinha, A., Raghutla, C., & Vo, X. V. (2022). Decomposing Scale and Technique Effects of Financial Development and Foreign Direct Investment on Renewable Energy Consumption. *Energy*, 238, Article ID: 121758. <https://doi.org/10.1016/j.energy.2021.121758>
- Sharmiladevi, J. C. (2023). Impact Study of Agricultural Value Added on Foreign Direct Investment, Economic Development, Trade Openness for India Following ARDL Approach. *Cogent Economics & Finance*, 11, Article ID: 2270595. <https://doi.org/10.1080/23322039.2023.2270595>
- Solarin, S. A., & Sahu, P. K. (2023). Sectoral Foreign Direct Investment and Environmental Degradation: New Insights from Diversification of Energy Mix Containing Fossil Fuels and Renewable Energy. *Environmental Science and Pollution Research*, 30, 91853-91873. <https://doi.org/10.1007/s11356-023-28741-0>
- Song, Y., Deng, R., Liu, R., & Peng, Q. (2020). Effects of Special Economic Zones on FDI in Emerging Economies: Does Institutional Quality Matter? *Sustainability*, 12, Article No. 8409. <https://doi.org/10.3390/su12208409>
- Vitenu-Sackey, P. A. (2020). Financial Development, Foreign Direct Investment and Carbon Emissions: A Comparative Study of West Africa and Southern Africa Regions. *International Review of Research in Emerging Markets & the Global Economy*, 6, 1550-1569.
- Vladucu, L. V., & Munteanu, P. (2019). Foreign Direct Investments in the Context of Globalization and Sustainable Development. Investments Made to Enhance Renewable Energy Sources. *Annals—Economy Series, Constantin Brancusi University, Faculty of Economics*, 6, 167-176.
- Wahyudi, H., & Palupi, W.A. (2023). Relationship between Energy Consumption, Foreign Direct Investment, and Labor Force Participation Using the VECM Model: Empirical Study in OECD Countries. *International Journal of Energy Economics and Policy*, 13, 157-165. <https://doi.org/10.32479/ijeep.13999>

- Wang, Q., Wang, L., & Li, R. (2022). Renewable Energy and Economic Growth Revisited: The Dual Roles of Resource Dependence and Anticorruption Regulation. *Journal of Cleaner Production*, 337, Article ID: 130514. <https://doi.org/10.1016/j.jclepro.2022.130514>
- Wang, R., Usman, M., Radulescu, M., Cifuentes-Faura, J., & Balsalobre-Lorente, D. (2023). Achieving Ecological Sustainability through Technological Innovations, Financial Development, Foreign Direct Investment, and Energy Consumption in Developing European Countries. *Gondwana Research*, 119, 138-152. <https://doi.org/10.1016/j.gr.2023.02.023>
- Zakaria, M., & Bibi, S. (2019). Financial Development and Environment in South Asia: The Role of Institutional Quality. *Environmental Science and Pollution Research*, 26, 7926-7937. <https://doi.org/10.1007/s11356-019-04284-1>
- Zhang, J., Li, Z., Ali, A., & Wang, J. (2023). Does Globalization Matter in the Relationship between Renewable Energy Consumption and Economic Growth, Evidence from Asian Emerging Economies. *PLOS ONE*, 18, e0289720. <https://doi.org/10.1371/journal.pone.0289720>
- Zhang, Y., Qamruzzaman, M., Karim, S., & Jahan, I. (2021). Nexus between Economic Policy Uncertainty and Renewable Energy Consumption in BRIC Nations: The Mediating Role of Foreign Direct Investment and Financial Development. *Energies*, 14, Article No. 4687. <https://doi.org/10.3390/en14154687>