

# Design of a Patch Antenna Based on Wood Substrate for WLAN Application

Dieudonné Ningarukiye<sup>1</sup>, Olivier Videme Bossou<sup>2</sup>, Denis Bukuru<sup>3</sup>,  
Canesius Uwizeyimana<sup>3</sup>, Fiston Rukerandanga<sup>4</sup>

<sup>1</sup>Doctorale School, University of Burundi, Bujumbura, Burundi

<sup>2</sup>National Advanced School of Engineering of Yaoundé, Cameroun Laboratory of Electrical Engineering, Mechatronics and Signal Processing, Yaoundé, Cameroun

<sup>3</sup>Departments of Applied Sciences, Bujumbura, Burundi

<sup>4</sup>Faculty of Engineering Sciences, Bujumbura, Burundi

Email: dieudonningarukiye09@gmail.com, obossou@gmail.com, denbukuru@gmail.com, canesius14@gmail.com, filston2006@gmail.com

**How to cite this paper:** Ningarukiye, D., Bossou, O.V., Bukuru, D., Uwizeyimana, C. and Rukerandanga, F. (2026) Design of a Patch Antenna Based on Wood Substrate for WLAN Application. *Open Journal of Antennas and Propagation*, **14**, 13-21.  
<https://doi.org/10.4236/ojapr.2026.141002>

**Received:** March 23, 2025

**Accepted:** March 10, 2026

**Published:** March 13, 2026

Copyright © 2026 by author(s) and Scientific Research Publishing Inc. This work is licensed under the Creative Commons Attribution International License (CC BY 4.0).  
<http://creativecommons.org/licenses/by/4.0/>



Open Access

## Abstract

This paper details the design of a rectangular patch antenna intended for WLAN wireless communication systems. The antenna operates within a frequency range of 1.5 GHz to 3.5 GHz and is constructed using a wooden substrate with a relative permittivity of 1.77, a loss tangent of 0.0577, and a thickness of 1.6 mm. The antenna's performance is evaluated through key parameters, including a reflection coefficient ( $S_{11}$ ) of  $-43.9987$  dB, standing wave ratio (VSWR) of 1.0127, gain of 2.4 dB, directivity of 8.7 dB, efficiency of 23.36%, bandwidth of 180 MHz, and radiation diagram where obtained using ANSYS HFSS software. The results demonstrate that using wood as the substrate provides satisfactory performance for the antenna design.

## Keywords

Patch Antennas, Wood Substrates, ANSYS HFSS Software

## 1. Introduction

In recent years, the telecommunications field has experienced significant advancements, including notable improvements in antenna technology for applications like Wi-Fi and Bluetooth [1] [2]. Antennas are crucial components in wireless communication systems, and as technology has evolved, antenna designs have continuously improved to meet the growing demands of telecommunication applications. Among the various antenna types, patch antennas are widely used in

wireless communication.

Most of the patch antennas currently available are manufactured using advanced materials such as Kapton, FR4, and PET [3] [4]. While these materials offer excellent performance, they are costly. To reduce production costs, several studies [5] [6] have explored the use of wood substrates in antenna design, showing promising results compared to high-tech materials. Wooden substrates offer advantages such as relatively low permittivity and tangent losses, which allows for increasing bandwidth and prevents field lines from becoming confined within the dielectric. Another major advantages of wood substrates is their greater availability on the local market, facilitating easier procurement.

Although previous studies have investigated wood substrates within the frequency range of 8.2 GHz to 12.4 GHz [7], there has been no research conducted within the 1.5 GHz to 3.5 GHz range. With the goal of promoting the use of natural resources, we propose the use of Cameroonian wood as an alternative substrate. This material, which is readily available in Africa, has a relative permittivity of 1.77 and a loss tangent of 0.0577 [6].

## 2. The Geometric Parameters of the Studied Antenna

The antenna under study consists of a rectangular radiating element fed by a microstrip line. Rectangular patch antennas are widely favored in telecommunications due to their optimal configurations compared to other microstrip antenna geometries [8]. To ensure an effective antenna design, it is essential to carefully select the substrate placed between the patch and the ground plane [9]. The choice of substrate directly influences other key parameters of the antenna.

The structure of our antenna is shown in **Figure 1**, where the radiating element, or patch, is positioned above the ground plane with the substrate in between. The patch can take various forms [10]. Both the ground plane and the radiating element are made of aluminum. For this design, we substitute the commonly used substrates with a wooden substrate that has a relative permittivity of 1.77, a loss tangent of 0.0577, and a thickness of 1.6 mm [6]. The assembly process of the antenna will utilize a simple bonding method using Zhanlida glue.

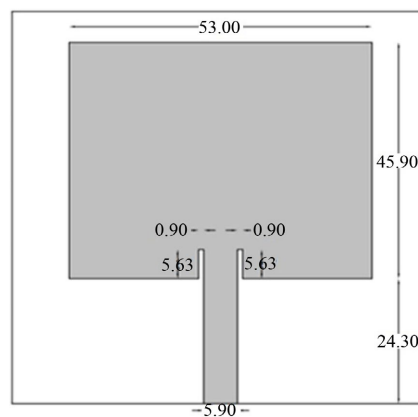

**Figure 1.** Geometry of the proposed antenna.

The designed antenna operates within the 1.5 GHz to 3.5 GHz range, making it suitable for WLAN wireless systems. The primary dimensions of the antenna include the patch length ( $L$ ), patch width ( $W$ ), and the substrate height ( $H$ ). The antenna is fed by a microstrip line with a width of  $W_0$ , positioned in front of the radiating element. This microstrip line is excited by a “Lumped” type excitation port to simulate a wave source (Figures 2-6). Detailed specifications for these parameters used in the antenna design are provided in Table 1.

**Table 1.** Proposed antenna parameter values.

Parameter Symbols	Details of the Parameters	Values [mm]
$H$	Height of the substrate	1.6
$W_p$	Width of the Patch	53
$L_p$	Length of the patch	45.9
$W_0$	Width of power line	5.9
$L_0$	Length of power line	24.3
$\epsilon_{\text{reff}}$	constante dielectric a effective	1.66
$\Delta L$		0.897
$L_{\text{eff}}$		51.22
	Slots	
a		0.9
b		5.63
c		0.9
d		5.63

In this paper, the following equations are used to calculate the width ( $W$ ) and length ( $L$ ) of the patch. Equations (1) through (8) provide the necessary formulas to determine the width of the radiating element, the effective length, and the overall length of the radiating element [8] [11].

$$W = \frac{1}{2f_r \sqrt{\mu_0 \epsilon_0}} \sqrt{\frac{2}{\epsilon_r + 1}} = \frac{c}{2f_r} \sqrt{\frac{2}{\epsilon_r + 1}} \quad (1)$$

$$\epsilon_{\text{reff}} = \left[ (\epsilon_r + 1)/2 + (\epsilon_r - 1)/2 \right] \left[ 1 + 12h/w \right]^{-\frac{1}{2}} \quad (2)$$

The extended length  $\Delta L$  of the patch: 
$$\frac{\Delta L}{h} = 0.412 \left[ \frac{(\epsilon_{\text{reff}} + 0.3) \left( \frac{w}{h} + 0.264 \right)}{(\epsilon_{\text{reff}} - 0.258) \left( \frac{w}{h} + 0.8 \right)} \right] \quad (3)$$

$$\Delta L = h \times 0.412h \left[ \frac{(\epsilon_{\text{reff}} + 0.3) \left( \frac{w}{h} + 0.264 \right)}{(\epsilon_{\text{reff}} - 0.258) \left( \frac{w}{h} + 0.8 \right)} \right] \quad (4)$$

$$\text{the effective length of the patch, } L_{eff} = L + 2\Delta L \tag{5}$$

$$\text{the length of the patch, } L = L_{eff} - 2\Delta L \tag{6}$$

$$L_0 = \frac{\lambda}{2} = \frac{\lambda}{2\sqrt{\epsilon_{reff}}} \tag{7}$$

$$W_0 = h \left[ 5.7961 \left( \epsilon_r^{-0.95} \right) \right] \tag{8}$$

The length of the feed line and its width are calculated using Equations (7) and (8).

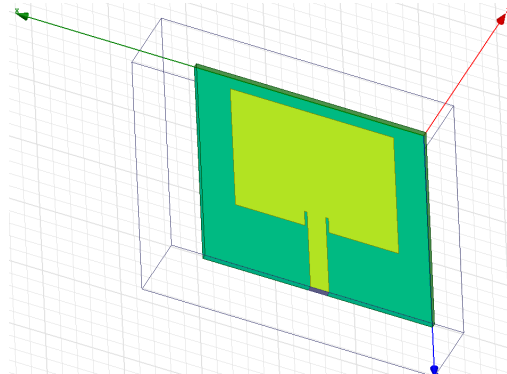

**Figure 2.** Rectangular microstrip patch antenna proposed in the HFSS software.

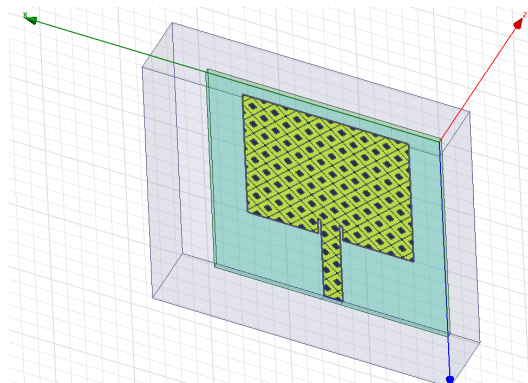

**Figure 3.** Proposed rectangular microstrip patch antenna showing PerfectE1.

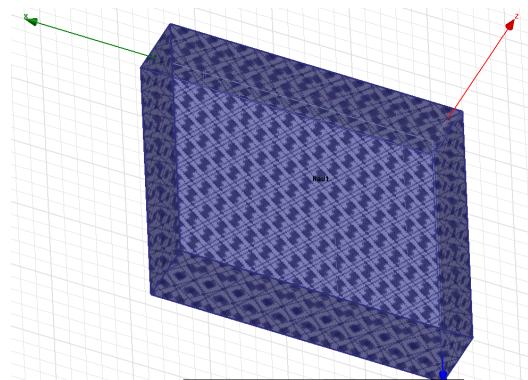
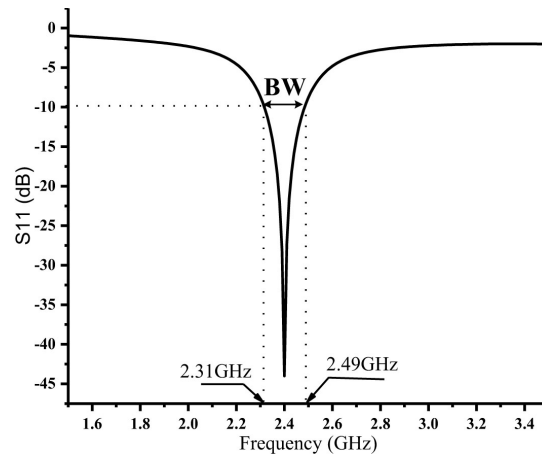

**Figure 4.** Rectangular microstrip patch antenna enclosed in a radiating air box.

### 3. Simulation and Discussion Results of the Proposed Antenna

#### 3.1. The Reflection Coefficient

The reflection coefficient value must be less than  $-10$  dB for demonstrating effective antenna performance [12]. Therefore, the simulation results obtained for the reflection coefficient of our antenna is seen in **Figure 6**. It has a reflection coefficient ( $S_{11}$ ) value of  $-43.9987$  dB and a bandwidth of 180 MHz at a frequency of 2.4 GHz. This is a very small value and very low power loss, indicating that maximum power is radiated towards the antenna.



**Figure 5.**  $S_{11}$  return losses.

#### 3.2. VSWR (ROS)

**Figure 6** illustrates the standing wave ratio (SWR) as a function of the operating frequency. The result shows that at a frequency of 2.4 GHz, the standing wave ratio is 1.0127. This value falls within the range of  $1 \leq \text{SWR} \leq 2$  [13], indicating good impedance matching and confirming that nearly all the power is radiated efficiently.

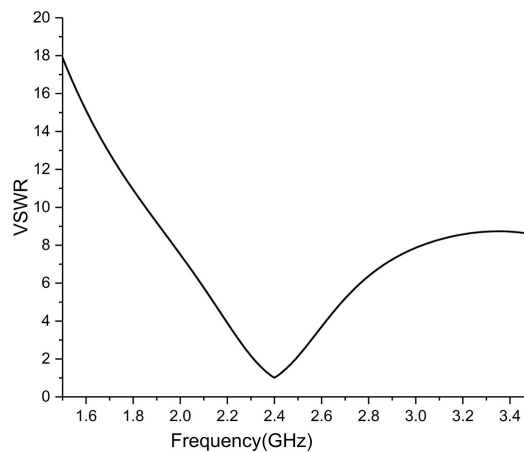

**Figure 6.** Stationary wave ratio ROS.

### 3.3. 2D Radiation Pattern

The radiation pattern of an antenna offers a visual representation of the different lobes in both the horizontal plane ( $\phi = 0$  degrees) and the vertical plane ( $\phi = 90$  degrees), with a focus on the primary lobe. **Figure 7** shows the radiation pattern in both the H-plane and E-plane at a frequency of 2.4 GHz, clearly indicating that the radiation pattern is directional.

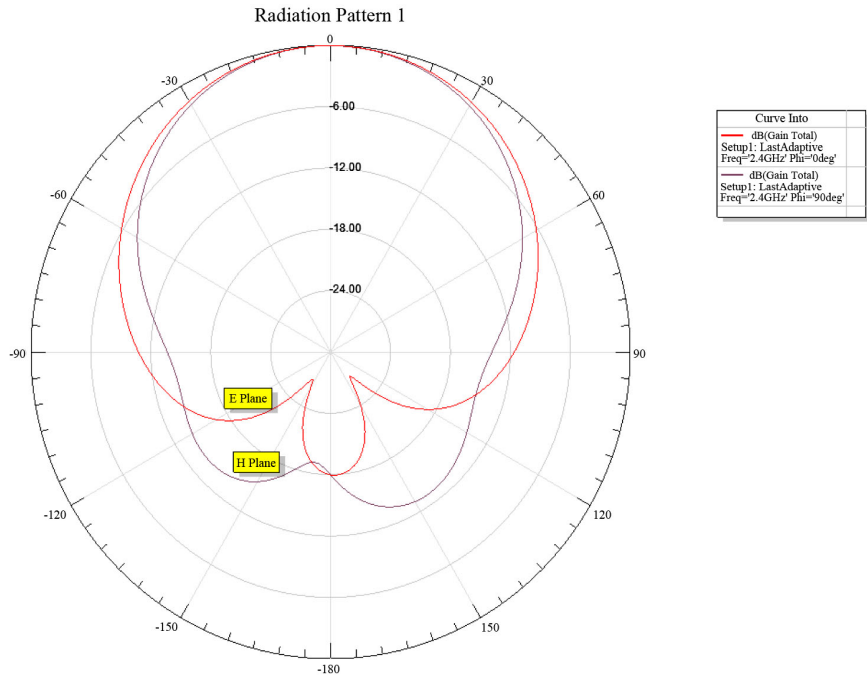

**Figure 7.** Radiation pattern.

### 3.4. Gain and Directivity

The maximum value of gain and directivity of the proposed antenna are 2.4 dB and 8.7 dB, respectively, for the operating frequency of 2.4 GHz see **Figure 8(a)** and **Figure 8(b)**.

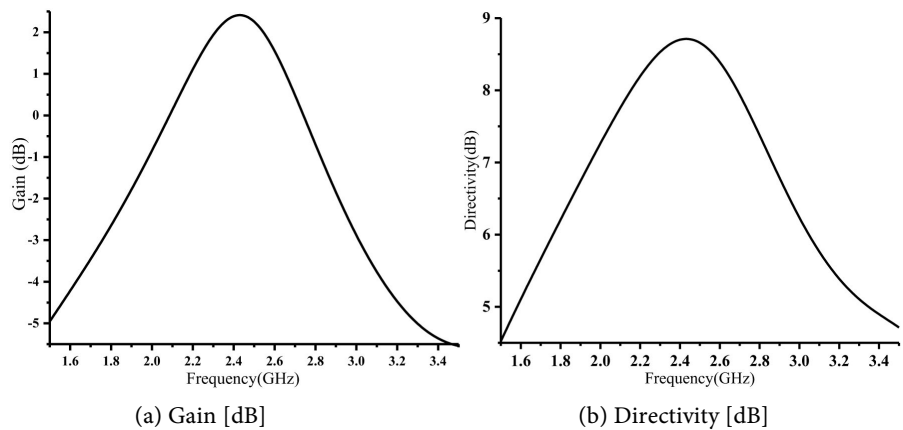

**Figure 8.** Gain and directivity.

### 3.5. 3D Radiation Pattern

The 3D radiation pattern indicates the obtained gain representation and directivity. We observe that the radiation pattern of the proposed antenna presents the maximum value of the directivity of 20 dB at operating frequency of 2.4 GHz as seen in **Figure 9**.

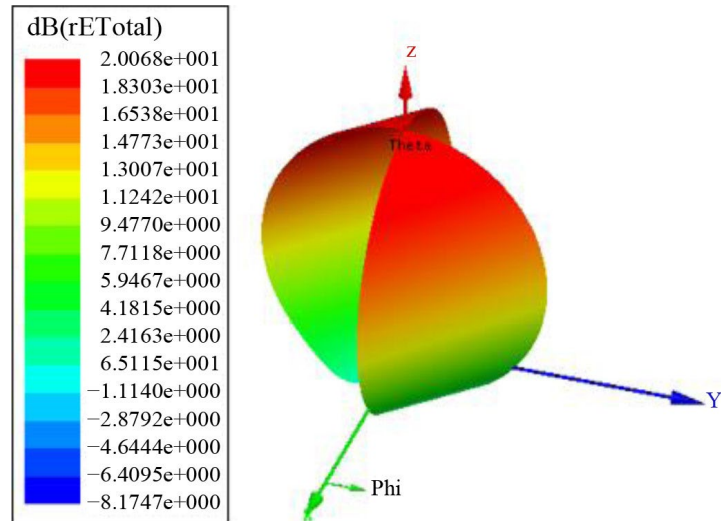

**Figure 9.** Total gain.

### 3.6. Efficiency

The proposed antenna in this article has an efficiency of 23.37% as seen in **Figure 10**.

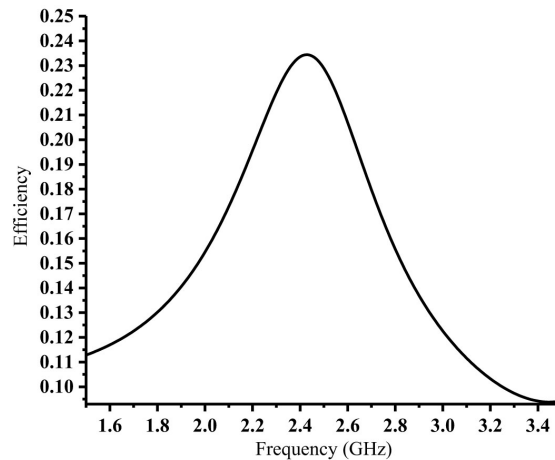

**Figure 10.** Efficiency.

### 3.7. Performance Comparison with the Reported Works

**Table 2** presents a performance comparison between commonly used substrates and the wooden substrate. The proposed antenna, designed using the wooden substrate, has a lower return loss compared to other antennas designed using

other substrates. It also has very low standing wave, a wider bandwidth, and very high directivity compared to the reported works. However, it has very low gain compared to [2], which leads us to observe very low efficiency.

**Table 2.** Performance comparison with reported works done using other substrates.

Ref.	Substrate	$S_{11}$ (dB)	VSWR	BW (MH)	Gain (dB)	Efficiency (%)	Directivity (dB)
[10]	FR4	-29.69	1.2	-	8.4	90	-
[11]	R0430b	-32.29	1.04	330	-	-	8.55
[2]	Rogers RT5870	-22.58	1.604	25.5	6.655	-	8.012
[4]	RT Duroid 5880	-13.4	1.537	-	-	42	-
<b>Our work</b>	<b>Wood</b>	<b>-43.9</b>	<b>1.013</b>	<b>180</b>	<b>2.4</b>	<b>23.36</b>	<b>8.7</b>

## 4. Conclusion

In this article, we designed a rectangular patch antenna using a wooden substrate, operating within the 1.5 GHz to 3.5 GHz frequency range for WLAN applications. To achieve this, a parametric study was conducted using the HFSS electromagnetic simulator on a wood substrate with a relative permittivity of 1.77, a loss tangent of 0.0577, and a height of 1.6 mm. The results demonstrated that using wood as a substrate provides satisfactory performance compared to conventional substrates. Wooden substrates are more readily available on the local market compared to the existing substrates. The results demonstrate that utilizing natural resources, as wood, leads us to develop a patch antenna usable in the WLAN wireless communication system.

## Conflicts of Interest

The authors declare no conflicts of interest regarding the publication of this paper.

## References

- [1] Yildirim, B.S., Cetiner, B.A., Roqueta, G. and Jofre, L. (2009) Integrated Bluetooth and UWB Antenna. *IEEE Antennas and Wireless Propagation Letters*, **8**, 149-152. <https://doi.org/10.1109/lawp.2009.2013371>
- [2] Muhammad, N.A. and Idris, Y. (2016) Design and Analysis of Rectangular Microstrip Patch Antenna for Global WLAN Applications Using Matlab and CST Microstudio Software. *International Journal of Engineering Science & Computing*, **6**, 3732-3737.
- [3] Priya, S., Rawat, V.S., Kumar Sonvani, V. and Vishwakarma, S.K. (2021) Design of 2.4 GHz Patch Antenna with Rectangular Slot for WLAN Application Using SIW Technique. 2021 *Emerging Trends in Industry 4.0 (ETI 4.0)*, Raigarh, 19-21 May 2021, 1-4. <https://doi.org/10.1109/eti4.051663.2021.9619267>
- [4] Ibanez Labiano, I. and Alomainy, A. (2021) Flexible Inkjet-Printed Graphene Antenna on Kapton. *Flexible and Printed Electronics*, **6**, Article ID: 025010. <https://doi.org/10.1088/2058-8585/ac0ac1>
- [5] Janapala, D.K., Nesasudha, M., Neebha, T.M. and Kumar, R. (2019) Flexible PDMS Antenna Backed with Metasurface for 2.4 GHz Wearable Applications. 2019 *IEEE 1st*

- International Conference on Energy, Systems and Information Processing (ICESIP)*, Chennai, 4-6 July 2019, 1-3. <https://doi.org/10.1109/icesip46348.2019.8938235>
- [6] Mosig, J.R. and Zurcher, J.-F. (2014) Laboratory of Electronic and Signal Processing. University of Yaounde I.
- [7] Bossou, O.V., Mosig, J.R. and Zurcher, J. (2010) Dielectric Measurements of Tropical Wood. *Measurement*, **43**, 400-405. <https://doi.org/10.1016/j.measurement.2009.12.008>
- [8] Colaco, J. and Lohani, R. (2020) Design and Implementation of Microstrip Patch Antenna for 5G Applications. 2020 *5th International Conference on Communication and Electronics Systems (ICCES)*, Coimbatore, 10-12 June 2020, 682-685. <https://doi.org/10.1109/ices48766.2020.9137921>
- [9] Pandian, M.K. and Chinnadurai, T. (2019) Design and Optimization of Rectangular Patch Antenna Based on FR4, Teflon and Ceramic Substrates. *Recent Advances in Electrical & Electronic Engineering (Formerly Recent Patents on Electrical & Electronic Engineering)*, **12**, 368-373. <https://doi.org/10.2174/2352096511666180705121554>
- [10] Parmar, N., Saxena, M. and Nayak, K. (2014) Review of Microstrip Patch Antenna for WLAN and WiMAX Application. *International Journal of Engineering Research and Applications*, **4**, 168-171.
- [11] Errifi, H., Baghdad, A., Badri, A. and Sahel, A. (2014) Effect of Change in Feedpoint on the Antenna Performance in Edge, Probe and Inset-Feed Microstrip Patch Antenna for 10 GHz. *International Journal of Emerging Trends in Engineering and Development*, **1**, 80-93.
- [12] Faisal, M., Gafur, A., Rashid, S.Z., Shawon, M.O., Hasan, K.I. and Billah, M.B. (2019) Return Loss and Gain Improvement for 5G Wireless Communication Based on Single Band Microstrip Square Patch Antenna. 2019 *1st International Conference on Advances in Science, Engineering and Robotics Technology (ICASERT)*, Bangladesh, 3-5 May 2019, 1-5. <https://doi.org/10.1109/icasert.2019.8934474>
- [13] Al Kharusi, K.W.S., Ramli, N., Khan, S., Ali, M.T. and Halim, M.A. (2020) Gain Enhancement of Rectangular Microstrip Patch Antenna Using Air Gap at 2.4 GHz. *International Journal of Nanoelectronics and Materials*, **13**, 211-224.