



New Proposal for Seismic Rehabilitation of Hospitals in Cuba

Víctor M. Valdés^{1*}, Dalia Pupo¹, Rolando M. Fernández¹, Roberto Martínez¹, Carlos A. Recarey²

¹Enterprise of Engineering Services and Design, Holguín, Cuba

²Center of Studies of Computational Mechanics and Numerical Methods in Engineering, UCLV, Santa Clara, Cuba

Email: *victor.valdes@vertice.cu

How to cite this paper: Valdés, V.M., Pupo, D., Fernández, R.M., Martínez, R. and Recarey, C.A. (2019) New Proposal for Seismic Rehabilitation of Hospitals in Cuba. *Open Access Library Journal*, 6: e5825.

<https://doi.org/10.4236/oalib.1105825>

Received: September 30, 2019

Accepted: November 22, 2019

Published: November 25, 2019

Copyright © 2019 by author(s) and Open Access Library Inc.

This work is licensed under the Creative Commons Attribution International License (CC BY 4.0).

<http://creativecommons.org/licenses/by/4.0/>



Open Access

Abstract

This work presents the seismic evaluation and the rehabilitation proposal of one essential facility, specifically the “Guillermo Luis” hospital of the Moa city in Holguín. The authors intend to apply, for the first time, a non-conventional technique used in Cuba to seismic protection of facilities health. This solution is based on seismic energy dissipation mechanisms, by mean of shear link device. The Shear Link-Bozzo device, allows the “GIRON” precast concrete systems to improve the inadequacies of behavior under earthquake lateral load by avoiding the undesired failure mechanism, such as: weak story and torsion due to great stiffness and mass asymmetries. All the above mentioned aspects drive us to take some alternative measures of seismic retrofit for these typical structures, based on the incorporation of the passive energy dissipation that allows the system to behave in the elastic range of response. By means of this solution it is possible to reduce the interference during the rehabilitation works, and also to reduce the time of break services of the hospital.

Subject Areas

Earthquake Engineering, Structural Engineering, Seismic Rehabilitation of Structures, Safety Hospitals, Disaster Reduction

Keywords

Linear and Nonlinear Analysis, Prefabricated Existing Buildings, Seismic Structural Analysis, Shear Link-Bozzo Device, Dissipation Devices

1. Introduction

The international experience has demonstrated that retrofit/rehabilitation techniques that incorporate non-conventional seismic energy dissipation or isolation

devices are often the only way to achieve the required seismic performance for certain types of structural systems. In many countries these technologies are easier to apply in the structural rehabilitation of existing buildings, because of the owners' interest in achieving high performance goals for their buildings and they can afford the cost associated with the design, manufacture and installation of seismic energy dissipation devices. The special situation of Cuba in this aspect is given by the high hazard of some areas of the eastern region ground peak acceleration (PGA) from 0.139 to 0.513 g, in combination with a low recurrence of shaking, this may lead some engineers to think that it is not necessary to take special measures such as the installation of dissipation devices. As will be shown below, it is a fact that its use could be very well justified in health facilities protection and rehabilitation of important buildings in order to control the high performance required of these structures.

The construction of health facilities using prefabricated GIRON system is very common in the eastern region of Cuba. It is a structural system developed in Cuba since the 70's decade, attending to the state of knowledge of the moment about the levels of seismic hazard. Because of this, in many regions of our country, no special requirements of the earthquake design and structural conception were dictated. Thirty years later, the revision of the conceptual design and the evaluation of preliminary resistance brings to the light some deficiencies that still subsist in these structural systems, like: heavy weight, low redundancy, weak floor, short columns, big torsional problems and little ductile capacity, according to that, they may prove to be very inefficient to achieve an adequate seismic behavior.

This investigation intends as the main objective to contribute with the necessary criteria to demonstrate the feasibility of the incorporation in Cuba, the innovative techniques of energy dissipation, which have been successfully utilized all over the world to improve the performance demanded to the health essential buildings.

The particular building under study was selected due to the interest of the investor in knowing the seismic safety of the hospital built with GIRON system in a zone classified as high seismic risk according to the most recent standard provisions [1].

The building under study is the Clinical-Surgical Hospital "Guillermo Luis" located in Moa. **Figure 1(a)** shows the regional location of the Moa city at the Holguin province of Cuba. Because of its extension the building was fragmented in parts for its study. Taking advantage of the construction joints that divide the two blocks of the main building it was divided into two part or blocks, establishing as priority the assessment and retrofit of the part of the structure corresponding to the building of hospitalized patients, called Block 2, which is shown in **Figure 1(b)**. The information collected for the initial works proved to be essential in the development of the later stages, related with the computations of vertical loads and seismic horizontal actions. More than 600 drawing documentation belonging to the original layout (architectural and structural drawings) of



(a)



(b)

Figure 1. (a) Regional location of the building at the Moa city, Holguin province, Cuba; (b) View of the “Guillermo Luis” hospital, Building of Block 2 area in which hospitalized patients are located.

the Block 2 was consulted. Several visits were made to the site in order to know the current condition of the structure, its technical state and the modifications made during its lifetime. Serious difficulties were identified due to the modifications to the original layout, which included changing the location of medical equipment, implicating significant changes of weights respect to the original structure.

2. Motivation of the Research

Necessity of increase the seismic safety of health facilities built with GIRON System according to state of knowledge of the last normative [1], GIRON is a precast concrete structural system developed without seismic requirements.

Typical layout of GIRON system has been used in other buildings like hospital, hotel, school located in zones of low, medium to high earthquake hazard of Cuba.

As part of this study, previous retrofit proposals made with the intention of improving the system’s response were also reviewed, and they were found to be very intrusive and without a proved cost-benefit impact.

3. Description of the Structural System

The GIRON system is a structure of precast reinforced concrete frames, con-

formed by unidirectional frames and precast concrete shear walls. The structure obey to a basic grid of 6.00 m \times 6.00 m and 6.00 m \times 7.50 m and height between structural levels of 3.30 m. Shear walls could be placed in both directions since they were conceived originally to take the horizontal wind and earthquakes loads. As **Figure 2** and **Figure 3** illustrates, the existence of a structural first floor supported only on pedestals (short columns) of 40 cm \times 60 cm and, could yield structural instability due to the great inertial forces generated above this floor level (weak story mechanism) during earthquakes.

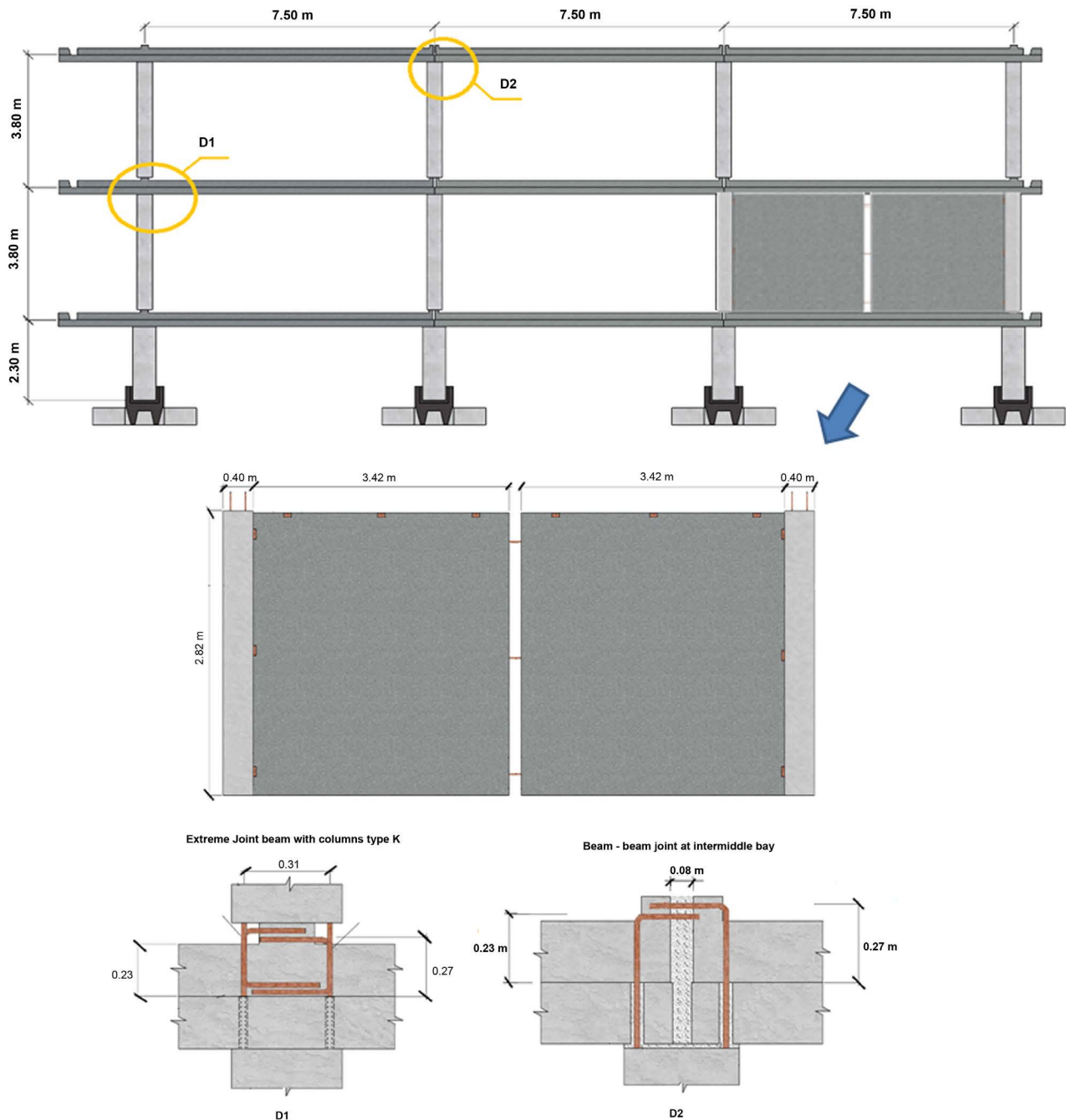

Figure 2. Typical structural sections of GIRON System. Frames in the beam direction (transverse frame).

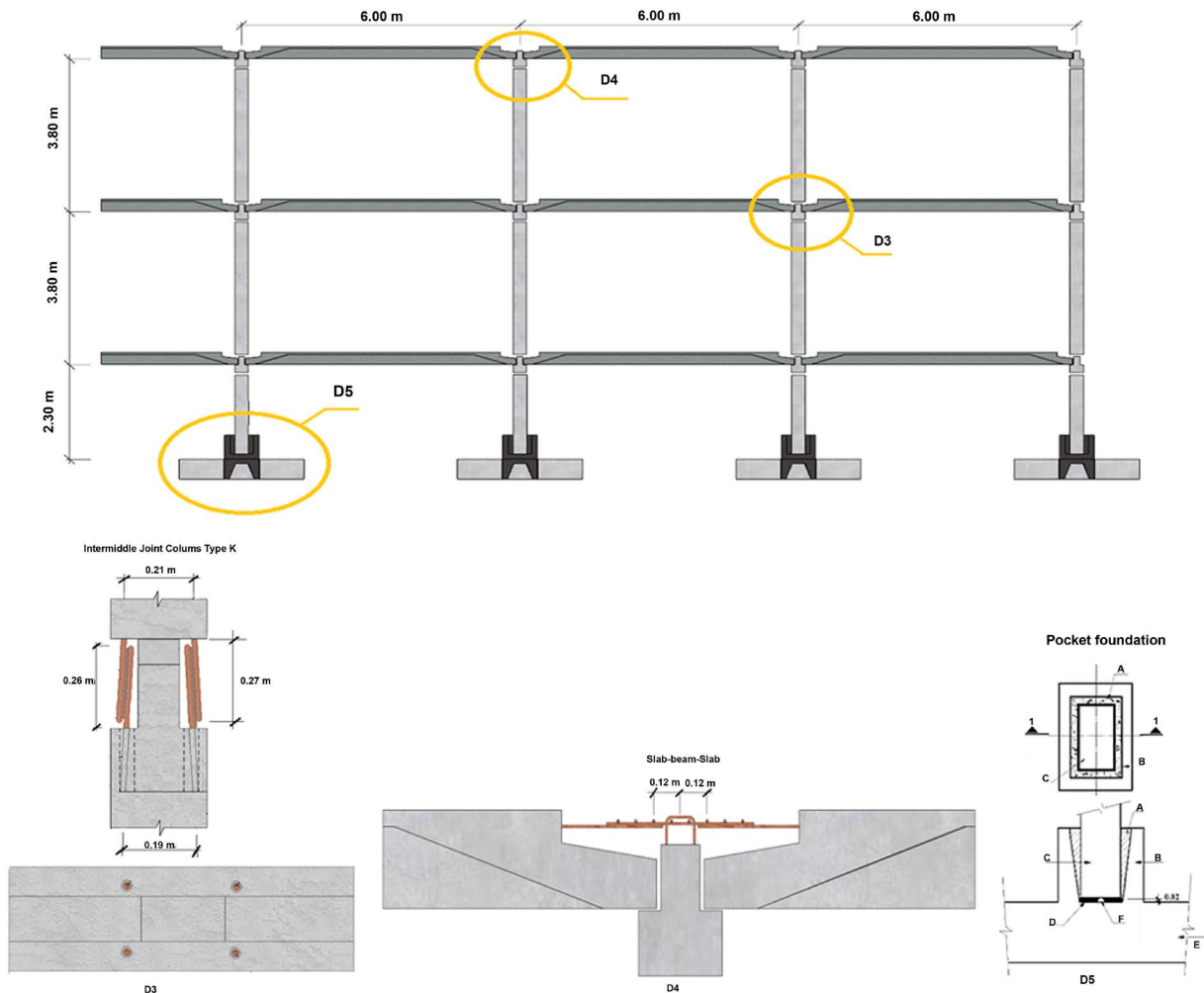

Figure 3. Typical structural sections of GIRON System. Frames in the direction of the double T slab (longitudinal frame).

3.1. GIRON System Characteristics

- Precast Frame-Shear Wall Structure,
- Low ductile capacity,
- One directional, that is, non redundant,
- Inadequate mechanism of seismic shear strength transfer of joints,
- Lateral resistance conceived according to the old seismic standard.

The lack of symmetry in the shear walls disposition, characterizes the solutions observed in most of facilities health, conditioned by the requirements of the architectural drawings.

This violation of the basics conceptions given by the typical layout, originally intended for this system, causes as a result the weakening of the structure. It is one of the reasons for its assessment and retrofit become necessary. **Figure 4** shows the shear walls disposition in structural drawings, at the level 1 to 5.

3.2. Connections of the Systems

The lacks of stirrups (transverse reinforcement) necessary to achieve the adequate

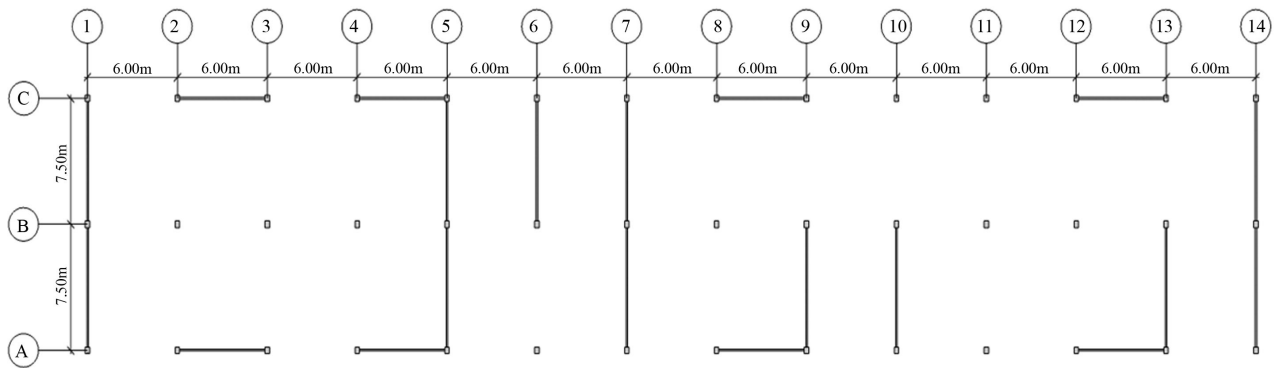

Figure 4. Floor plan of block 2, where hospital admissions and surgery units are located.

confinement in the section core of beam-column joint, limit the column shear capacity at this zone, weakening the connection between members of the system under lateral forces. From **Figure 5(a)** and **Figure 5(b)** it is shown that the connection specifications does not allow to emulate a monolithic structure, making the system behave like pinned in the beams directions and semi-rigid in the direction of the slabs. It is an additional weakness of the system to resist lateral forces.

3.3. Floor Diaphragms. Critical Points

The floors diaphragms conformed by prefabricated TT slabs units have disadvantages for the adequate seismic response, it is related to the weakness of longitudinal joints between TT slabs along the edges, which could tend to crack during the strong seismic shakes. **Figure 5(c)** gives the details of the joint between slabs to conform the floor diaphragm.

3.4. Lateral Bracing

The shear wall were detailed with mechanical shear transfer, so this allow a pure shear behavior to the horizontal actions, by transferring only shear forces to the beams and axial forces to the columns, like showed in **Figure 6(c)**.

4. Conventional Method Proposed to GIRON Structural System Rehabilitation

The solutions provided so far to improve the seismic response of the GIRON structural system have followed the intuitive strategy of strengthening the entire structure [2]. They have being intended to eliminate weak floor mechanism, increasing section size of structural element of lateral loads resistant system, like columns, pedestals and foundations. Bracing system measures, to stiffen the superstructure, are added. Another set of measures, such as, reinforcement of existing foundation elements in the critical areas, combining with the reinforcement of a limited number of columns and introducing deep girders like tie linking pedestals at the first structural level. Some of these structural measures are displayed in **Figure 7**. All of these methods involve high costs of interventions,

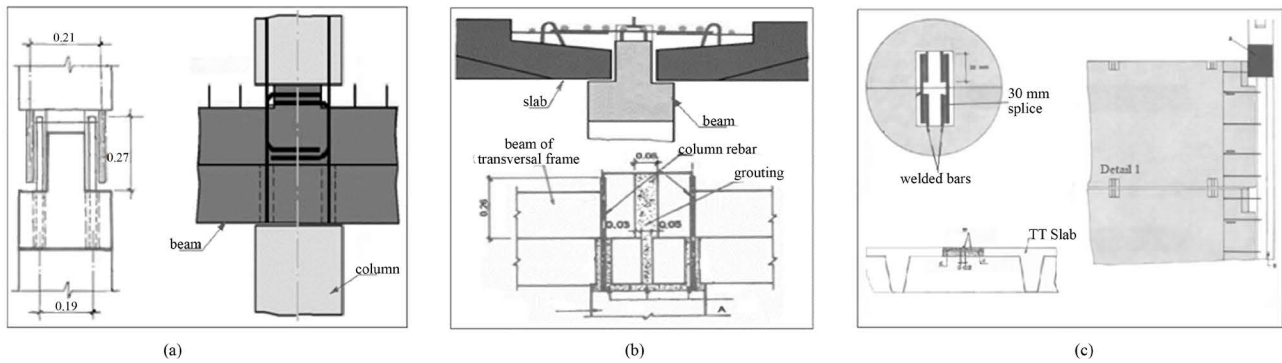

Figure 5. Typical details of the joints in the system: (a) Beam-column joint; (b) The TT slab-beam joint; and (c) Longitudinal joint between TT slabs.

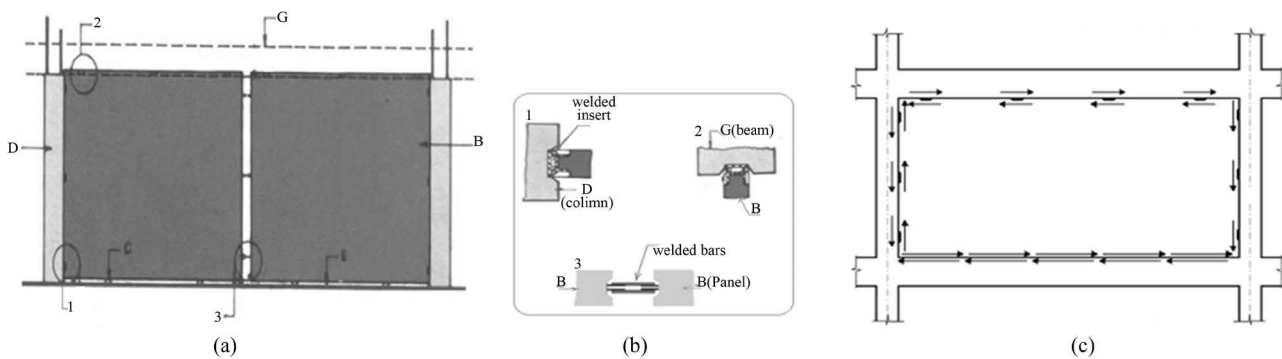

Figure 6. (a) Dispositions of the inserts on structural elements; (b) Details of the joints between shear walls and walls-frame; (c) Shear walls behavior in the conceived for the GIRON system.

and entail too invasive strategies at the expense of long disruptions of the health service. To cite a specific example of this, the rehabilitation of GIRON school buildings is about 405,084.46\$ USD.

Conclusions of Evaluation Proposal of Conventional Methods of Seismic Retrofit of GIRON

- The same inefficient system of lateral loads transference is retained.
- The intrusiveness and cost of these solutions made them unattractive and impractical to implement.
- These solutions do not warrantee the compliant with demand/capacity ratio in all structural members.

5. Evaluation of the Seismic Hazard

The intra-plate bound that separates the Cuban Oriental Block from the rest of the island could be one the main source of earthquakes hazard for this region, Chuy *et al.* (2005) [3]. Nevertheless, the greatest hazard comes from the Eastern Earthquake Zone, in which earthquakes of magnitude 8.0 are probable to occur. The city of Moa is located within a zone classified as a moderated seismic risk, it means that the seismic events can cause damages to the structures, and therefore some earthquake resistant measures have to be taken. This consideration will be

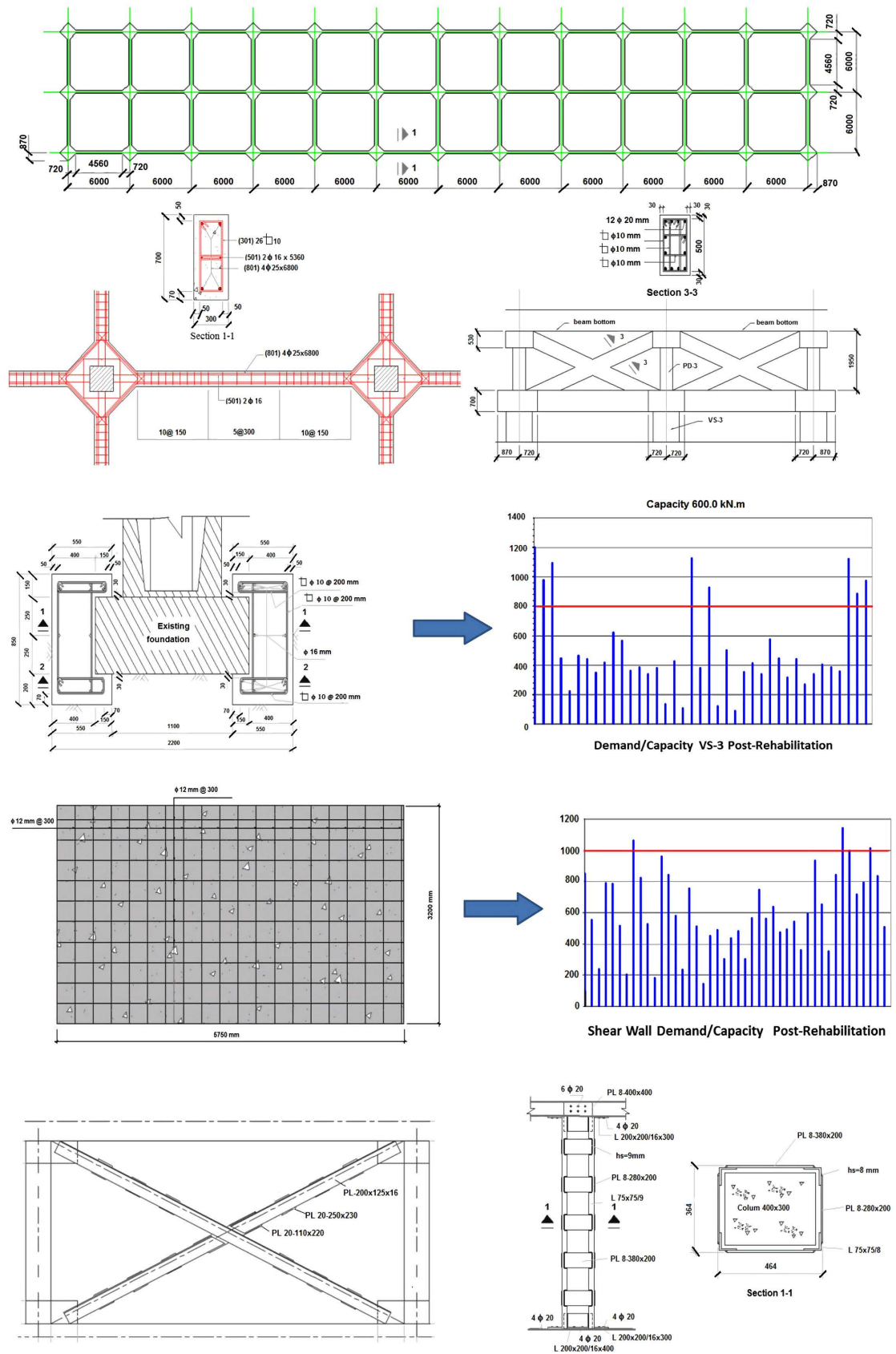

Figure 7. Proposal of conventional methods of seismic retrofit of GIRON system.

applicable in all the structures as a function of its occupational category, and the level of seismic protection defined according to the probability of exceeding an earthquake design.

At the time of seismic performance assessment of the structure the NC 46:2013 standard in force on that date [1] set out maximum horizontal spectral accelerations values in a range between 0.40 and 0.50 g for short periods (S_s) and from 0.15 to 0.20 g for long periods (S_l). In this standard [1] for design of new structures, had already been set the minimum levels of seismic protection. For instance, the 4.2.4.2 section of this standard define as a “severe earthquake” the one which have the probability 5% of been exceeded in 50 years, and it is used for structural design of “Important” and “Essential” buildings. According to this, an essential building had the same exceedance probability (earthquake design) as an important one, the acceptable lateral drift for each one of them, makes the difference with respect to both seismic protection objectives. The 4.2.4.3 section define as an “extreme earthquake” the one which have the probability 3% of been exceeded in 50 years, and it is used for structural design of essential buildings.

The seismic design spectrum generated for soil site D, at Moa city, corresponding to the earthquake design selected according to the seismic protection level defined by proposal of the Cuban Standard [1] for the essential buildings, **Figure 8**.

6. Phase of Analysis of the Structure without Rehabilitation

The handling of the model data of the structure, which includes the processing of the weights of all the prefabricated elements of the GIRON System, the determination of the weights and masses, the position of the center of masses and of stiffness, the shear forces and torsional moments by levels and gravitational loads, were all processed by the Seismic Revision of Structural Systems (REVSE) program, which was developed by the authors to execute several tasks: 1) to check structural systems for seismic safety, 2) to export through API to the SAP200

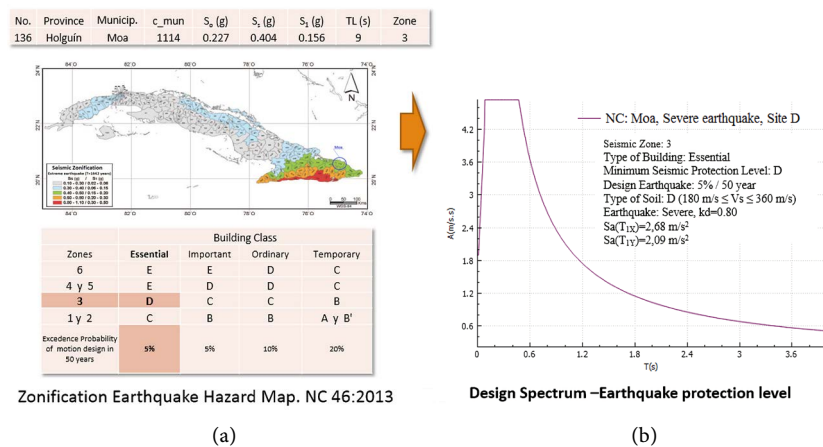

Figure 8. (a) Earthquake Hazard, oriental zone of Cuba, and Geographical area of the Moa site where the hospital is located; (b) Earthquake design defined in terms of Elastic Response Spectrum for the Cuban Seismic Standard, NC 46:2013 for the Moa City.

software and OpenSees, where the analysis is completed. Some of the interactive modules of REVSE are shown in **Figure 9**.

The structural modeling was carried out in the 19 version of the software SAP2000, in which the main dynamic characteristics of the building were calculated, by means of a modal analysis. **Figure 10** shows the first mode period in the transverse direction, T_{1X} , is 0.962 s and in the longitudinal direction, T_{1Y} , is 0.756 s. These high values of periods yielded for a building with just five levels of height, evidence the insufficient lateral stiffness in both directions at the structural first floor (formed only for short columns) and the lack of shear walls in both directions on the top floors. The masses and stiffness center of the floors are shown in **Table 1**.

Table 1. The masses and stiffness center of the floors.

Level	Cr _x (m)	Cr _y (m)	Cm _x (m)	Cm _y (m)
1	35.05197	7.43333	38.1043	8.621
2	35.05197	7.43333	40.381	7.8083
3	35.05391	7.40459	39.6733	7.9908
4	34.92901	7.3524	39.7251	8.0713

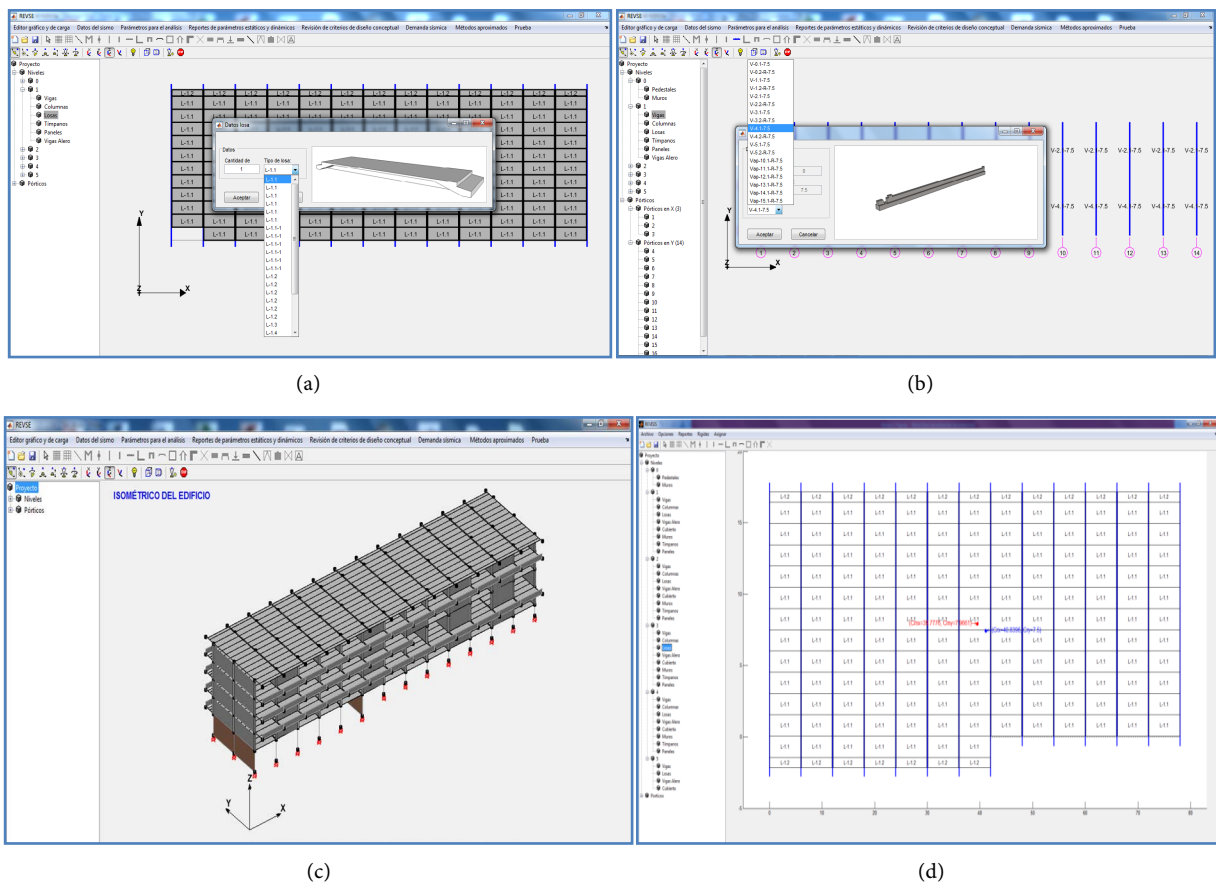

Figure 9. Automated processing in the REVSE Software (a) Insertion of slabs, (b) Insertion of beams, (c) Isometric of the building, (d) Computation of the center of masses and stiffness position per floor.

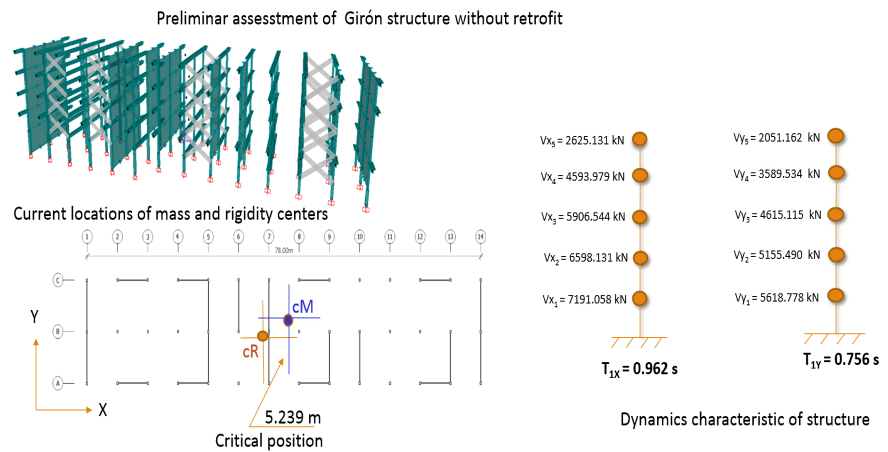

Figure 10. Preliminary assessment of GIRON structure without retrofit.

The way in which the shear forces were distributed in the structure, and the location of failed elements before the proposed retrofit measures, demonstrates the high susceptibility to the formation of a weak floor mechanism, which can be seen in **Figure 11**.

6.1. Criteria Followed for Rehabilitation

Due to the limited ductility of the system, low shear capacity of the critical elements (piers at the first level), the retrofit strategies was focused to three main goals:

1) To increase the global lateral resistance solving in a feasible way the most important mechanisms of failure detected in the structural system, these are:

a) Weak floor.

b) Brittle failure mechanism controlling the response of the earthquake lateral load resistant system, that is, shear capacity in shear walls and short columns (piers at the first level).

2) To take advantage of elastic response in the elements of the main structural system, canalizing the ductility demands to the energy dissipation devices by mean of yielding of SLB.

3) Achieve the least intrusion possible during the retrofit activities, in order to maintain the functioning of that area of the hospital.

Why to use dissipation device?

- The positions of existing shear walls can't be relocated or removed as these are adjusted to the functional distribution of the spaces defined in the architectural drawings, so it is very difficult to avoid torsional sway.
- Minimum level of intrusive activities during interventions is an imperative, that's the reason to the addition of new shear walls were disregarded.

Why yielding devices?

- To reduce as much as possible the force-based behavior by looking for the desirable mechanism based on the fluency of the devices.
- The yielding occurs at low levels of shear strain levels, which is according to seismic hazard of Cuba.

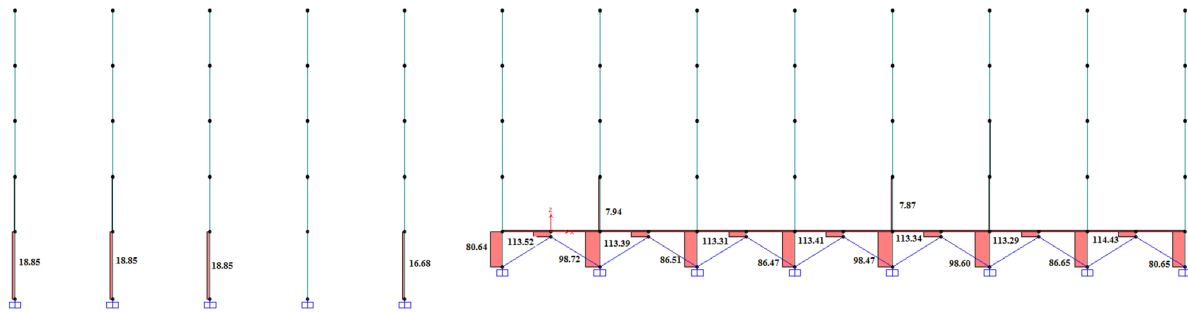

Figure 11. Shear strength in the elements of structure without rehabilitation.

- Take advantage of the dual resistance mechanism (Shell-Frame) to install it in weak areas.
- Being these essentially passive does not require activation power.

6.2. Technical Characteristics of the Dissipation Device SLB

The hysteretic dissipation devices of seismic energy Sher Link-Bozzo (SL-B) [4] have been largely used with excellent results in different parts of the world. These kinds of devices, shown in **Figure 12**, have been used in some countries with high seismic risk, such as Perú, México and Ecuador.

The specific type of dissipation device selected by us for the seismic rehabilitation, the Shear Link (SL), is suitable for seismic protection because it permit a significant reduction of the forces induced by a seism of severe intensity, but it also could yield to lower level of earthquake forces, what permit its use in zones of low and moderate seismicity. More specifically, the Shear Link-Bozzo device is based on localized increase of ductility in parts of the building, as the system concentrates the plastic response in a specific point that can be supervised and then replaced, unlike another traditional technique of structural retrofit. The SL-B device guarantees two operating stages: 1) Before yielding of milled areas, in which it works according to a “shear mode”, 2) After yielding and web buckling “bending mode”. More details about works and the analytical model of shear link can be found in Nuzzo *et al.* (2014) [5]-[11].

6.3. Basics Assumption of the Structural Modeling

The Linear Static Equivalent Analysis was used as a first step to find the value of elastic shear force in order to size the device. The elastic response spectrum was reduced by a factor $R = 1.5$, regarding the low ductile capacity of the structural system and its low number of static indeterminacy. For the analysis, the shear wall was modeled like a bar impeded to take axial loads, simulating its shear behavior. This was carry out by creating a release in the frame element at the top (axial release) and a shear panel in the bottom. Then following an iterative process, “try and error” consisting of changing, in several positions the devices and running the model again, it was possible to avoid the failure mechanism of weak floor.

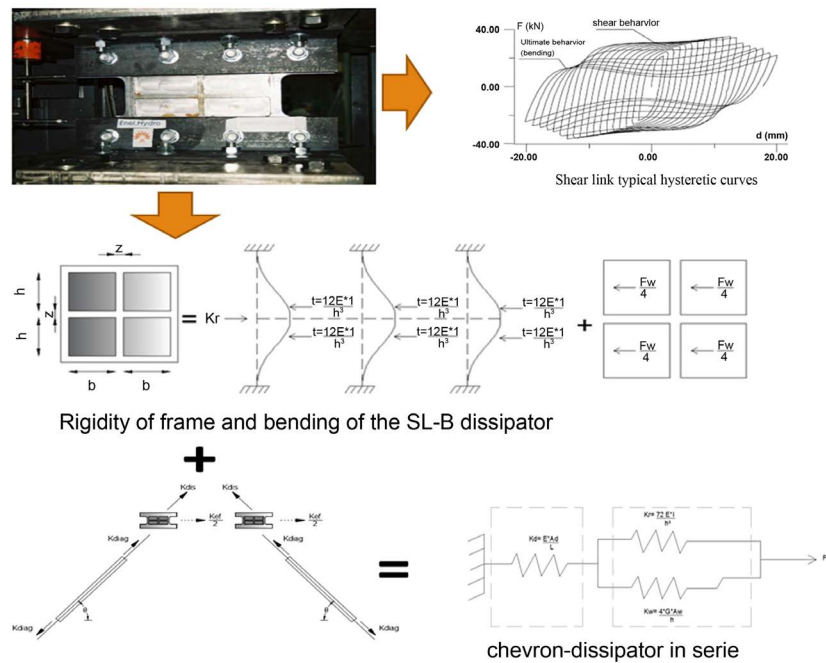

Figure 12. Seismic energy dissipation device type Sher Link-Bozzo (SL-B).

6.4. Dissipative Brace

A final solution that combine various ways of disposal shear-links devices with different structural elements for the whole building is displayed by axis and levels in Figure 13. This can be explained as fallows. Intended to avoid weak story mechanism, metallic yielding device SL-B in series with steel elastic brace was the solution proposed as shown in Figure 14(a). A combination of chevron-SL-B in strengthening shear walls capacity is shown in Figure 14(b).

Total number of devices required to eliminate pedestal and shear wall failure is given in Table 2.

7. Evaluation of the Effectiveness of the Proposal of Seismic Rehabilitation with Energy Dissipation Using SLB Bozzo

Considering that original condition of structure does not comply with the limit drifts as indicated by the standard [1], the criteria fallowed for rehabilitation was aimed at:

- To improve the strength path of the structure at global level.
- To reduce the torsional behavior.
- To eliminate any type of intrusive solution of retrofit.

The location of SL devices fallowed a try and error process until the acceptable forces in piers and shear-walls were achieved. The displacement control process of acceptable displacement, for performance, was done by selecting the most appropriate type of combination structural element-device. The new already reduced demands on the elements after the readjustment measures are shown in Figure 15 and Figure 16 which displays longitudinal and transversal direction of building respectively.

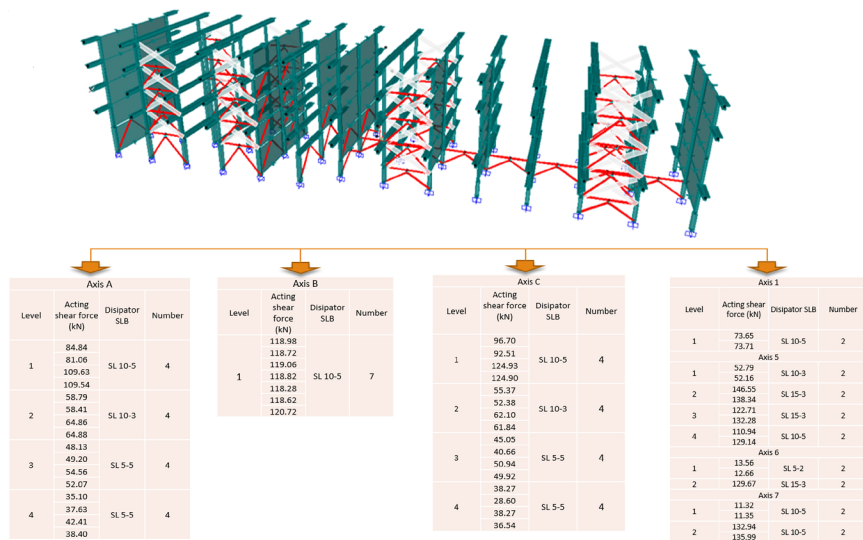

Figure 13. Selection and position by axis of SL-B dissipators in the structure.

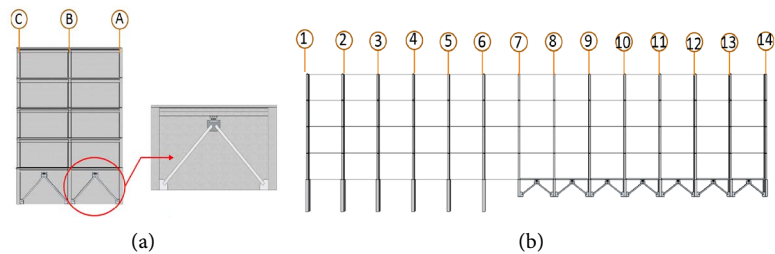

Figure 14. (a) Solution to strengthening shear walls capacity; (b) Solution to avoid weakness of the structural first floor.

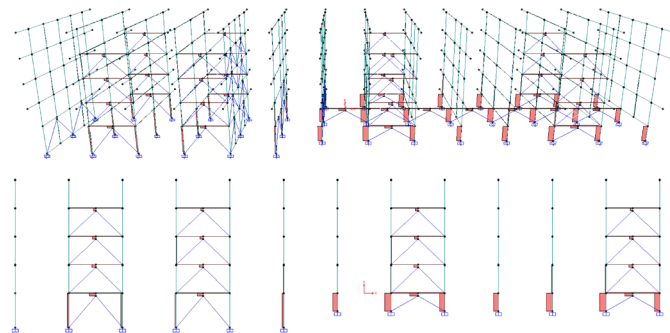

Figure 15. Final shear distribution on SLB Bozzo, in the longitudinal of the building.

Table 2. Types and number of device.

Type of Devices	Number
SL 10-5	21
SL 10-3	12
SL 15-3	14
SL 5-5	8
SL 5-2	2
Total	57

After the rehabilitation with the use of the SLB device the lateral drifts was reduced to the acceptable values, as pictured in **Figure 17**. Another parameter used to evaluation of efficiency was the study of the demand/capacity ratio of the structural members involved in the seismic response such as: columns and shear walls. **Figure 18** shows how the shear walls [12] demands were below capacity in all of the cases after retrofit.

Similar results were possible for the case of piers at the first floor, by eliminating the weak floor mechanism, shown in **Figure 19**. However, the impossibility of changing the shear wall position, left few alternatives for further modifications of the building torsional behavior. The use of the stiffening system allowed an acceptable reduction of the static eccentricity of 43%, 24%, 23% and 17% at the 1st, 2nd, 3rd and 4th story respectively.

The total cost of the SL-B rehabilitation proposal has been estimated to be about \$19,500.00 to reduce the estimated total losses in the block under analysis amounting to \$746,935.75.

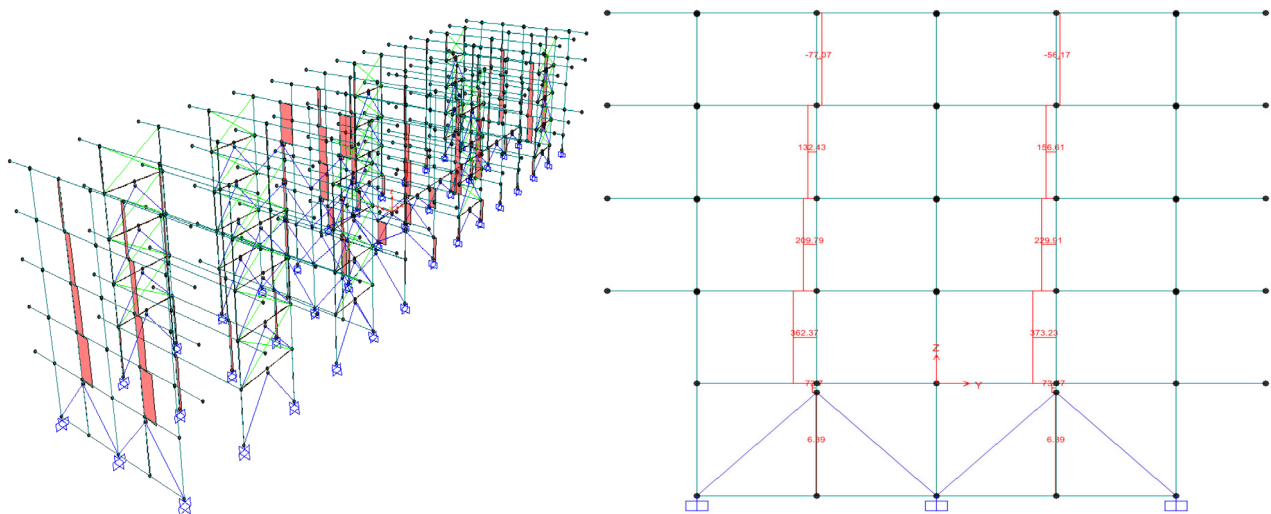

Figure 16. Final shear distribution on SLB Bozzo, in the transverse of the building.

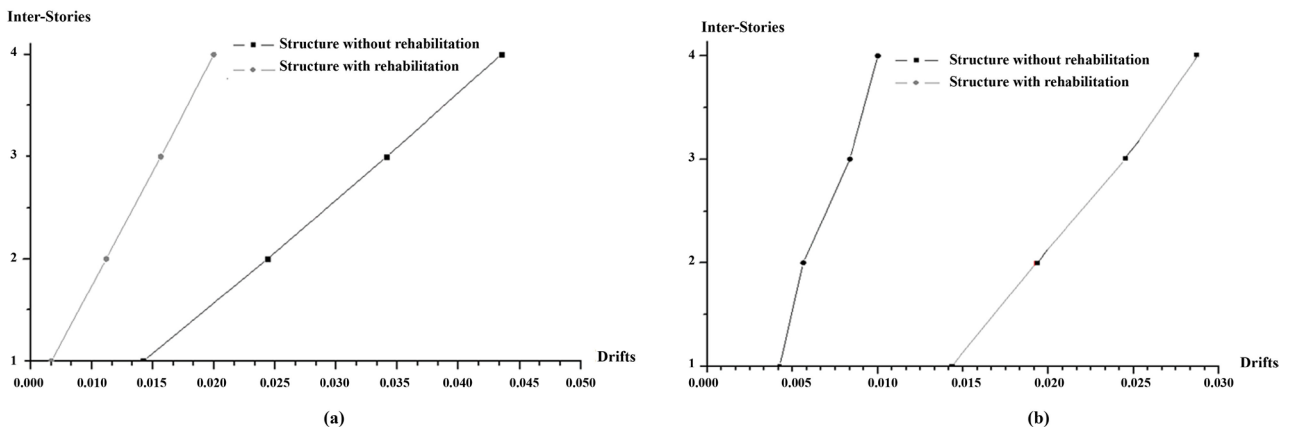

Figure 17. (a) Lateral drifts of the structure in transverse direction; (b) Lateral drifts of the structure in longitudinal direction.

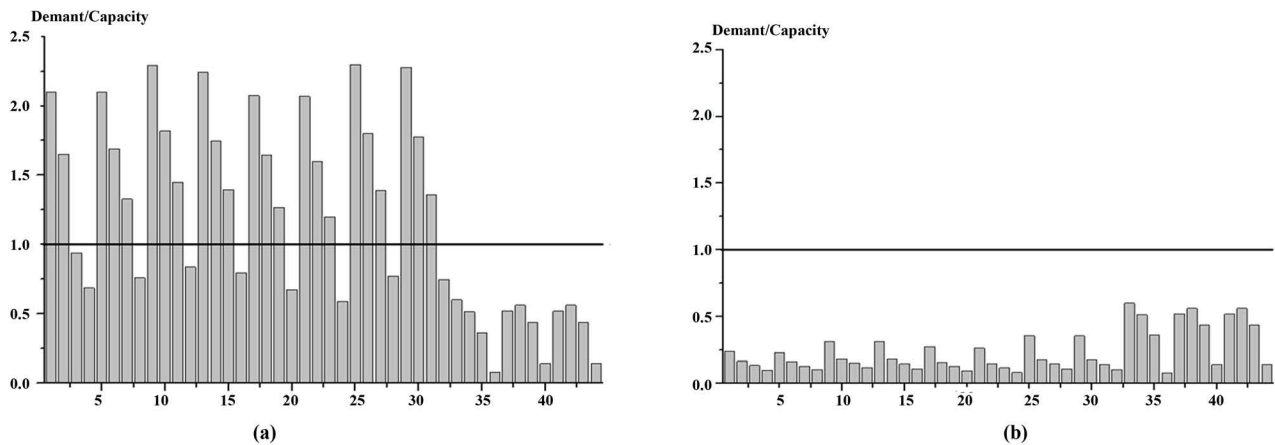

Figure 18. (a) Demand\Capacity ratio in shear walls in the critical direction (longitudinal) of structure without rehabilitation; (b) Demand\Capacity ratio in shear walls in the same direction (longitudinal) of structure after rehabilitation using SL-B devices.

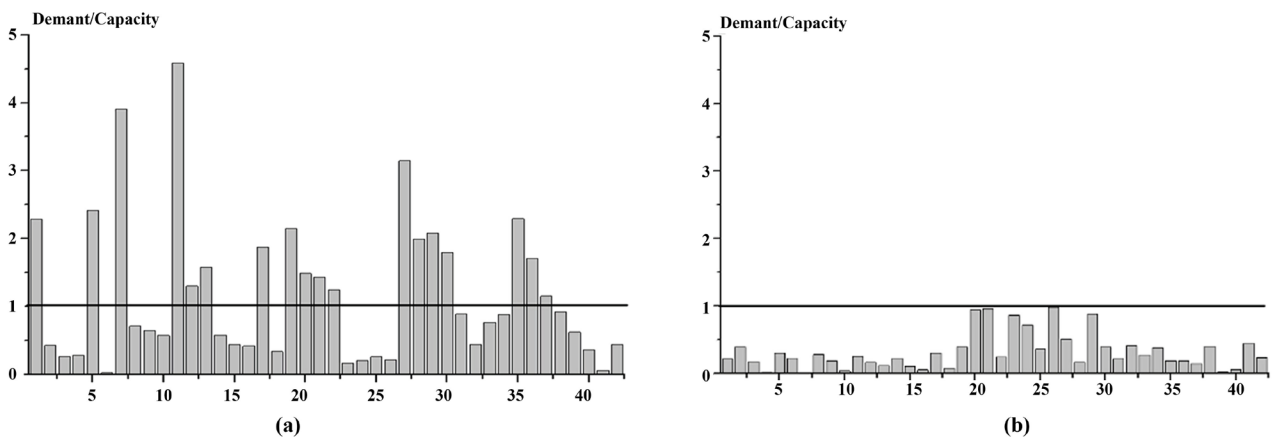

Figure 19. (a) Demand\Capacity ratio in piers, in the critical direction (transverse) of structure without rehabilitation; (b) Demand\Capacity ratio in piers in the critical direction (transverse) of structure after rehabilitation, using SL-B devices.

All these aspects show the efficiency, from several points of view, of the rehabilitation technique used with respect to the conventional ones.

8. Conclusions

The proposals of an innovative technique to be applied in the seismic rehabilitation of Guillermo Luis hospital in Moa city, Cuba, could be considered more feasible comparing to the traditional methods proposed to the date in our country. From the cost-benefit point of view, it could be less invasive and less expensive than the traditional ones.

As can be shown, the former proposals analyzed had serious limitations due to the seismic structural conception. The fact is that traditional rehabilitation methods don't allow to reply the same solution for all the health facilities in the country because of the high cost involved and the particularities of each structure, while the proposals of this work give a unique philosophy that makes easier the appraisal about the number, location and the different ways of installing the energy dissipation device SL-B in structures subjected to seismic retrofit in the

regions of moderated and high earthquake hazard of our island.

Acknowledgements

The authors are grateful in the first place for the valuable and disinterested collaboration shown by Dr. Ingeniero Luis Bozzo Rotondo, who offered all the technical assistance and documentation necessary to undertake this research.

Conflicts of Interest

The authors declare no conflicts of interest regarding the publication of this paper.

References

- [1] NC-46 (2013) Construcciones Sismo Resistentes. Requisitos básicos para el diseño y construcción.
- [2] Ruiz Ruiz, J.M. (2010) Evaluación de la seguridad sísmica de edificaciones prefabricadas 3 Simposio de edificios y sistema presforzados, Curso-Análisis y diseño de estructuras prefabricadas.
http://www.smie.org.mx/SMIE_Articulos/si/si_07/te_01/ar_03.pdf
- [3] Noas Hernández, J.L. and Chuy Rodríguez, T.J. (2005) Caracterización de la amenaza sísmica de la ciudad de Moa, Provincia Holguín. VI Congreso de geología (Geología 2005) Simposio de Sismicidad y Riesgo Geológicos. Habana, Cuba.
- [4] FEMA 273 C9 Seismic Isolation and Energy Dissipation (Systematic Rehabilitation).
- [5] Bozzo Rotondo, L.M. (2008) Numerical and Experimental Analysis of a Shear Link Energy Dissipator for Seismic Protection of Buildings. *14th World Conference on Earthquake Engineering*, Beijing, 12-17 October 2008.
- [6] Nuzzo, I., Losanno, D., Serino, G. and Bozzo Rotondo, L.M. (2014) A Seismic-Resistant Precast R.C. System Equipped with Shear Link Dissipators for Residential Buildings. *Proceedings of the Second International Conference on Advances in Civil, Structural and Environmental Engineering*, Zurich, Switzerland, 25-26 October 2014, 249-254.
- [7] Bozzo, L.M., Cahis, X. and Torres, L.L. (1998) A Shear Type Energy Dissipator for the Protection of the Masonry Infill Walls. *Proceedings of the Sixth U.S. National Conference on Earthquake Engineering*, Seattle, WA.
- [8] Cahis, X., Torres, L. and Bozzo Rotondo, L.M. (2000) An Innovative Elasto-Plastic Energy Dissipator for the Structural and No-Structural Building Protection. *12th World Conference on Earthquake Engineering*, Auckland, New Zealand, 1-8.
- [9] Gaxiola, G., Gonzales, H. and Bozzo, L.M. (2016) Proceso de análisis y diseño utilizando disipadores sísmicos tipo SLB. Ejemplos de aplicación.
- [10] Nanguillasmú Hernández, H.J. (2017) Modelado de disipadores histeréticos de energía en estructuras de concreto reforzado. Diferencias entre análisis en el plano y en tres dimensiones. *Revista Internacional de Ingenierías de estructuras*, **22**, 135-162.
- [11] Aguiar, R., Bozzo, L., Mora, D., Silva, H., Caiza, P. and Coyago, H. (2016) Protocolo de instalación de disipadores shear link bozzo SLB40-3 y placas Gusset en bloque estructural 4 de la UFA-ESPE. *Revista Internacional de Ingenierías de estructuras*, **21**, 127-150.
- [12] Valdés Jiménez, V.M., Pupo Ordoño., D., Fernández Pérez, R.M. and Martínez Al-

maguer, R. (2017) Use of the Dissipator SL-B in the Rehabilitation of Health Facilities in Cuba. *SMART 2017—Fourth Conference on Smart Monitoring, Assessment and Rehabilitation of Civil Structures*, Suiza, 1-8.

https://data.smar-conferences.org/SMAR_2017_Proceedings/papers/326.pdf