

Development of Localized Assessment of Municipal Wastewater Disposal Risks

Frederick Bloetscher¹, Daniel E. Meeroff¹, Brittanney Adelman²

¹Department of Civil, Environmental and Geomatics Engineering, Florida Atlantic University, Boca Raton, USA

²Department of Mathematics, Florida Atlantic University, Boca Raton, USA

Email: h2o_man@bellsouth.net

How to cite this paper: Bloetscher, F., Meeroff, D.E. and Adelman, B. (2024) Development of Localized Assessment of Municipal Wastewater Disposal Risks. *Journal of Water Resource and Protection*, **16**, 395-413. <https://doi.org/10.4236/jwarp.2024.166022>

Received: February 6, 2024

Accepted: June 4, 2024

Published: June 7, 2024

Copyright © 2024 by author(s) and Scientific Research Publishing Inc.

This work is licensed under the Creative Commons Attribution International License (CC BY 4.0).

<http://creativecommons.org/licenses/by/4.0/>



Open Access

Abstract

A means to develop a comparative assessment of the risks of available wastewater effluent disposal options on a local scale needs to be developed to help local decision-makers make decisions on options such as direct or indirect potable reuse options. These options have garnered more interest as a result of water supply limitations in many urban areas. This risk assessment was developed from a risk assessment developed at the University of Miami in 2001 and Florida Atlantic University (FAU) in 2023. Direct potable reuse and injection wells were deemed to have the lowest risk in the most recent study by FAU. However, the injection well option may not be available everywhere. As a result, a more local means to assess exposure risk is needed. This paper outlines the process to evaluate the public health risks associated with available disposal alternatives which may be very limited in some areas. The development of exposure pathways can help local decision-makers define the challenges, and support later expert level analysis upon which public health decisions are based.

Keywords

Potable Reuse, Wastewater, Effluent Disposal Risk, Risk Assessment

1. Introduction

Regulatory, political, and economic constraints have shaped wastewater management strategies throughout the United States. Historically the easiest means to dispose of wastewater is via the nearest river or stream. Such disposal goes back to Roman times. However, as the communities grew, the environmental degradation caused by this practice became clearer, and regulations to eliminate raw wastewater disposal were legislated. With passage of the Clean Water Act, other

effluent management options were pursued, and regionalization became the standard.

Today there are eight categories for waste disposal, none of which are available in every location. The most common are septic tanks which are limited to rural areas, surface water disposal and various and reclamation for beneficial reuse (irrigation) although the latter has not generally been implemented anywhere where water supplies are not limited. In some, options like ocean outfall and Class I injection wells might be available.

Bloetscher *et al.* [1] noted that there are studies that have “looked at risks related to wastewater disposal in agriculture [2] [3], tertiary treatment in surface water [4], injection wells [5], groundwater recharge [6] [7] and potable reuse [8] [9] [10] [11] [12],” but the closest to comparative risks outside Florida was performed by Soller *et al.* [13]. Other assessments have been performed to evaluate the risks associated with water distribution systems and reclaimed water programs associated with viral pathogens [14]-[19], but these were neither comparative assessments nor recent.

The first comparative risk assessment of multiple wastewater disposal options was undertaken by the University of Miami (UM) in 2000. The analysis was a comparative assessment of the public health and ecological risks associated with three effluent disposal alternatives available to wastewater utilities in Southeast Florida: ocean discharges (300 MGD), Class I injection wells (300 MGD), and surface water discharges (although the practice was abandoned in the 1970s in south Florida) [20] [21] [22] [23]. The use of reclaimed water was specifically excluded. Class I injection wells were deemed to have the lowest relative risk of the three alternatives analyzed.

A concurrent study conducted by Cadmus Group for USEPA in 2001 also found that in southeast Florida, Class I injection wells were the lowest risk as well, although in the Tampa area, the different depth and geology increase public health exposure. In the third study, Soller, *et al.* [12] compared risks from de facto reuse (surface water discharge), indirect potable reuse (IPR), and direct potable reuse (DPR) scenarios using their prior Quantitative Microbial Risk Assessment (QMRA) methodology and found direct potable reuse to have the lowest risk in California.

In Bloetscher *et al.* [1], six effluent disposal alternatives currently or potentially available to wastewater utilities in Southeast Florida: Class I injection well, ocean outfalls, surface discharges, irrigation with reclaimed water, indirect and direct potable reuse. Differing levels of treatment were required for each option:

- 1) Deep well injection utilizing secondary treatment plus filtration and high-level disinfection to the Boulder zone 3000 ft below the surface.
- 2) Ocean outfalls utilizing secondary treatment and disinfection.
- 3) Surface water (canal) discharges utilizing tertiary treatment (secondary wastewater treatment, filtration and nutrient removal plus ultraviolet disinfection).
- 4) Reclaimed water for irrigation purposes (secondary treatment plus filtration and high-level disinfection).

5) Indirect potable reuse (full treatment with reverse osmosis, plus ultraviolet light and advanced oxidation with storage in the aquifer or a pond).

6) Direct potable reuse using reverse osmosis, ultraviolet light and advanced oxidation prior to discharge to the headworks of a water treatment plant.

Septic tanks are not a consideration in urban areas, so are not considered. One other option is snow—an option in high mountain areas in the winter that assumes the same treatment as reclaimed water above, although UV is likely to be employed as opposed to chlorination. **Table 1** outlines a comparison of options by some jurisdictions.

2. Methods

The concept for the development of the comparative (relative) risk assessment used in the UM and FAU studies is based on the predictive Bayesian compound Poisson model proposed previously by Englehardt [24]. In both Englehardt *et al.* [20] and Bloetscher *et al.* [1], a conceptual model of the operating environment was developed for each disposal option. Elements of the conceptual models included regulatory constraints, hydrogeological and hydrological considerations, and potential pathways of health and ecological exposure. Water quality gathered from the utility effluents and receiving water was compared to applicable disposal and drinking water standards (see **Table 2**).

Figures 1-12 show the conceptual models used in Bloetscher, *et al.* [1]—odd numbered figures) with applicable exposure routes associated with each disposal method (even numbered tree diagram figures), with the treatment assumptions noted above. However, with these methods, many of the nodes provided minimal impact. The direct potable reuse scenario assumes the use of filtration, micro-filtration, reverse osmosis, ultraviolet light, and peroxide, prior to discharge to a water plant for treatment (see **Figure 11**). The only exposure is customers of the drinking water utility. Impacts from the water distribution piping are not part of the analysis since they are not fully controllable once the water leaves the treatment plant.

Table 1. Examples of wastewater disposal options.

Comparison	IW	OO	Reuse IRR	PR	SW	Snow
SE FL	x	x	x	x	x	
Colorado			x	x	x*	x
Texas	x		x	x	x***	
AA			x	x	x	
Central FL			x	x	x	
Detroit			**	**	x	

*WQ might need to be must greater than AWT for some discharges; **Lacks need for this option; ***recreation exposure.

Table 2. Summary of water quality based on treatment process and receiving waters [2].

Parameter Name	Drinking Water MCL	FAC Potable Reuse assumed limit	Surface Discharge DEP Regs - Impaired Water	Potable Reuse Treatment	AWT w UV Treatment Analysis	Reclaimed Water Analysis	Secondary Effluent	Raw Wastewater Typ.	Class I W				Brackish GW Concentration	Typ Surface water Concentration	Gulf of Mexico	Open Ocean
									Class I W Effluent Injection Zone	Lower Monitoring Zone	Upper Monitoring Zone	ASR Injection Zone				
Inorganic Analysis																
Arsenic (mg/L)	0.05	0.01	ND	ND	0.0013	0.0032	0.0027	0.0096	0.0073	0.0049	0.0022	0.0148	0.2	ND	ND	0.02
Barium (mg/L)	2	2	ND	ND	0.0936	0.0234	0.1844	0.0041	0.3633	0.089	0.4038	0.2442				0.05
Cadmium (mg/L)	0.005	0.005	ND	ND	0.0001	0.0013	0.001	0.0041	0.0122	0.0654	0.0019	0.001				
Chromium (mg/L)	0.1	0.1	ND	ND	0.0007	0.0029	0.0046	0.0135	0.0225	0.0063	0.0104	0.0039				
Cyanide (mg/L)	0.2	0.0002	ND	ND	0.0018	0.0153	0.5	0.006	0.0885	0.0043	0.0023	0.0039		ND		
Fluoride (mg/L)	4	4	ND	ND	0.94	0.42	0.79	0.4	0.86	1.47	1.58	0.19	0.8	ND	0.01	1.3
Lead (mg/L)	0.015	0.015	ND	ND	0.0003	0.0012	0.0044	0.069	0.108	0.0216	0.0022	0.0093	ND	ND		0.004
Mercury (mg/L)	0.002	0.002	ND	ND	0.0001	0.0003	0.00005	ND	0.0007	0.0012	0.0004	0.0003	0.1	ND		
Nickel (mg/L)	0.1	0.1	ND	ND	0.0021	0.0045	0.0105	0.023	0.0355	0.0248	0.0044	0.0025				
Nitrate (mg/L)	10	10	ND	ND	3.69	3.82	3.82	0.42	0.07	0.04	0.03	0.19				
Nitrite (mg/L)	1	1	ND	ND	0.013	0.5745	0.0093	0.0093	0.0248	0.0124	0.0063	0.005				
Selenium (mg/L)	0.05	0.05	ND	ND	0.0009	0.0035	0.0044	0.6374	0.0073	0.0036	0.0046	0.0006				10760
Sodium (mg/L)	160	160	ND	ND	64	75	114	8062	5514	1357	1215	80	100			
Antimony (mg/L)	0.006	0.006	ND	ND	0.1417	0.013	0.003	0.003	0.0188	0.0097	0.004	0.0014				
Beryllium (mg/L)	0.004	0.005	ND	ND	0.0041	0.0006	0.0006	0.0075	0.0099	0.005	0.0008	0.0001				
Thallium (mg/L)	0.002	0.002	ND	ND	0.0009	0.0016	0.3049	0.3049	0.013	0.0065	0.0008	0.0005				
Secondary Analysis																
Aluminum (mg/L)	0.2		ND	ND	0.05	0.0739	0.1996	0.1996	0.9166	0.7443	0.1625	0.8226				
Chloride (mg/L)	250		ND	ND	82.2	116.9	151.8	15302.5	9897	2203.3	2448.4	176.2	455	250	10679	19353
Copper (mg/L)	1		ND	ND	0.0033	0.0207	0.004	0.2099	0.0323	0.1324	0.0104	0.005	0.004	0.004	0.01	
Iron (mg/L)	0.3		ND	ND	0	0.1772	0.183	3	4.4503	19.2939	1.0791	0.4204	3	15	0.02	
Manganese (mg/L)	0.05		ND	ND	0.0237	0.0178	0.0384	0.0384	0.046	0.027	0.0431	0.0131	0.05	0.01	0.01	
Silver (mg/L)	0.1		ND	ND	0.001	0.0017	7.3	0.037	0.008	0.005	0.0039	0.0028	7.3	0.0001	ND	

Continued

Sulfate (mg/L)	250	ND	179.5	76.2	56.6	2379.2	1117.9	401	521.8	38.8	410	2712	
Zinc (mg/L)	5	ND	0	0.0229	0.0141	0.0076	0.0145	0.059	0.0822	0.0247		0.005	
Color (PtCo units)	15	ND	33	43.9	125	7.4	6.3	12.6	12	21.9	125	75	
Odor (TON)	3		2.5	11.0		1.2	3.3	2.1	13.5	0.7			
pH	6.5-8.5	6.3	7	6.9	7.5	7.7	7.9	7.7	7.5	8.1	7.5	7.8	8
TDS (mg/L)	500	1	1	528	550.7	28682	18328	4128	5240	533			
Foaming Agents (mg/L)	1.5	ND	0.1429	2.5	5.13	0.08	0.2534	0.118	0.0735	0.1933	5.13	ND	ND
Trihalomethane Analysis													
Total THMs (ug/L)	80	ND	26.85	62		0.1668	0.65	0.5	2.6065	0.0261			
Radiological Analysis													
Gross Alpha (pCi/L)	15		3.1667	0.4		9.675	7.3	4.1	24.66	5.55			
Miscellaneous Analysis													
Ammonia-N (mg/L)	-	2		8.8	20	3.7663	0.561	0.6442	0.575	ND	2.1	0.2	
Nitrogen, total (mg/L)	-	3		13.3	17	9.35	0.881	1.33	ND	ND	3.5	0.2	
Nitrogen, organic (mg/L)	-				1.6	0.9975	0.374	0.432	0.3067				
Nitrogen, total Kjeldahl (mg/L)	-			4.075	9.8	5.5267	0.474	0.678	0.83				
Ortho-phosphate (mg/L)	-				1.4	0.2337	0.045	0.0225	0.1333				
Phosphorus, total (mg/L)	-	1	ND	1.375	1.3	0.2708	0.2607	0.1292	0.255	ND	0.5	0	0.1
BOD (mg/L)	-	5		8.3	240	4.3	5.4	7	1.4	ND	3	0	
Total Coliform (col/100 ml)	-	0	ND	394.1	TNTC	33.5	7	0.5	6				
Water Temperature (°C)	-			25.3	25 to 30	22.8	23.5	24.3	24.4	20	varies to 30	37	15 - 37

Numbers are the average of the means of the measurements calculated with non-detects as zero and non-detects at their detection limit values.

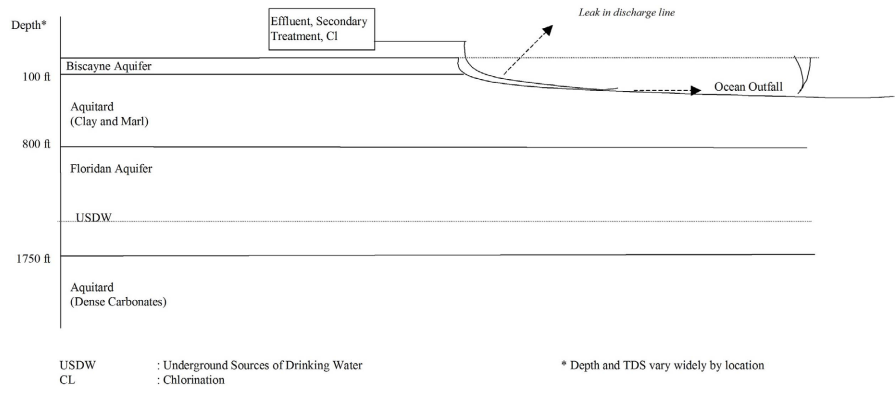

Figure 1. Ocean outfall disposal method route diagram (from [23]).

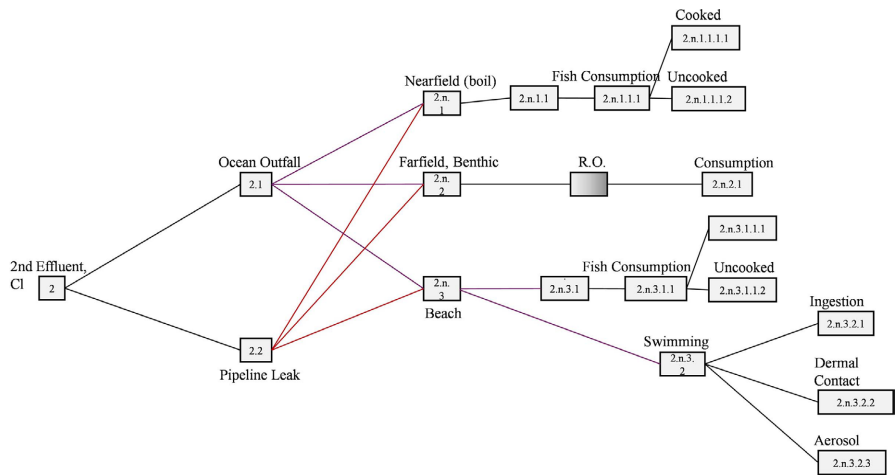

Figure 2. Ocean outfall risk tree diagram (from [23]).

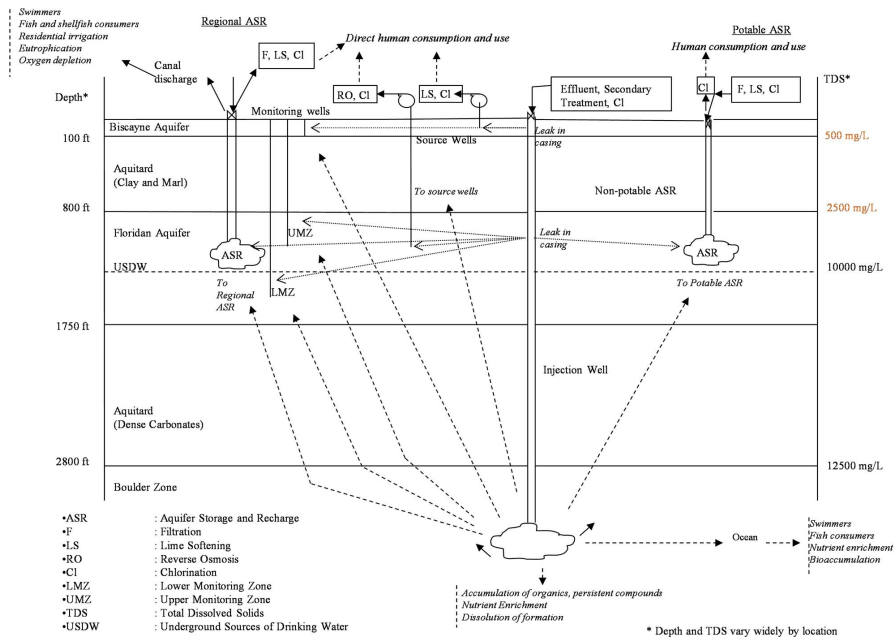

Figure 3. Injection well disposal method route diagram 9 from [23].

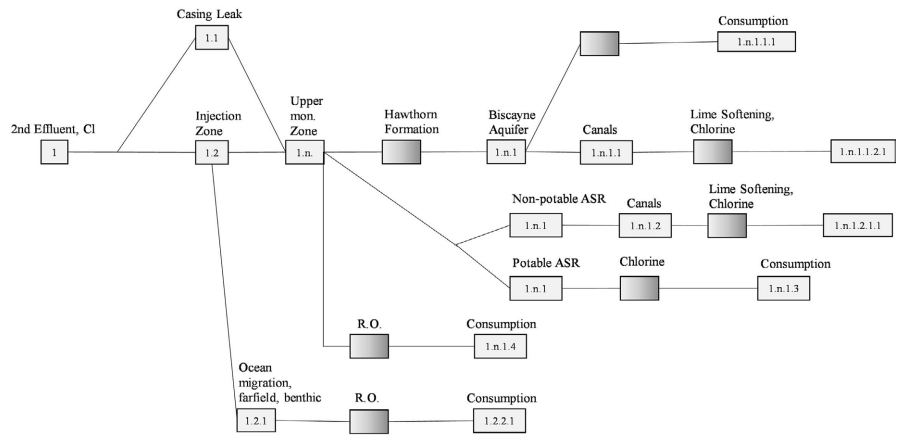

Figure 4. Injection well tree risk tree diagram (from [23]).

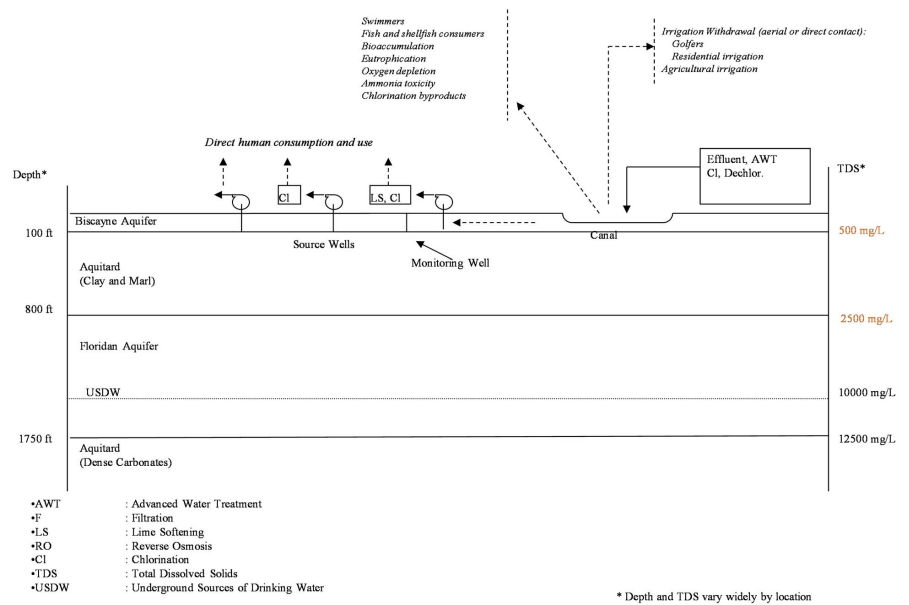

Figure 5. Surface water disposal method route diagram (from [23]).

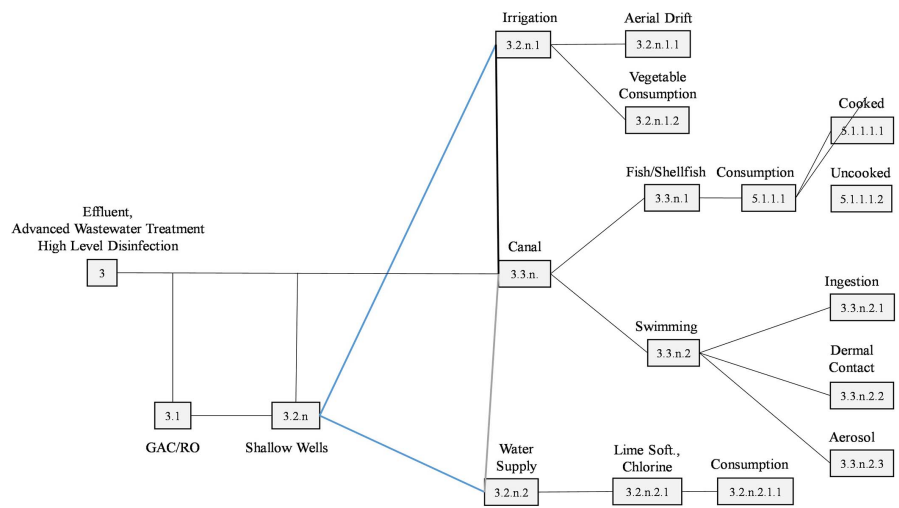

Figure 6. Surface water risk tree diagram (from Bloetscher [23]).

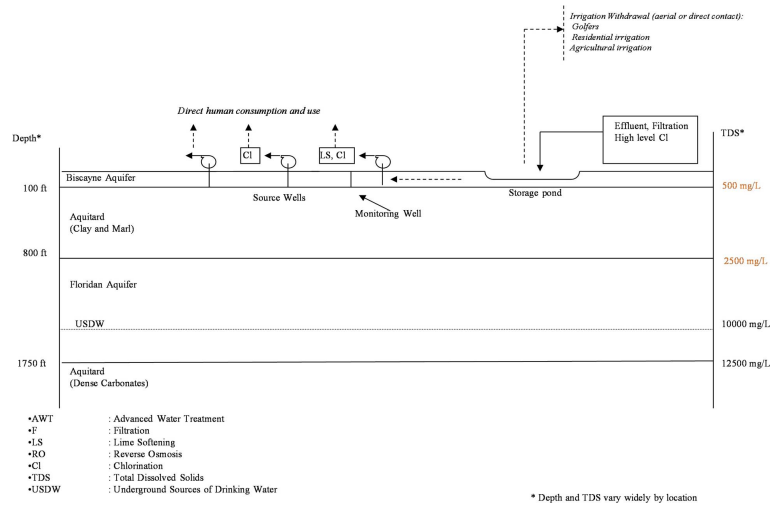

Figure 7. Reuse irrigation disposal method route diagram (from [2]).

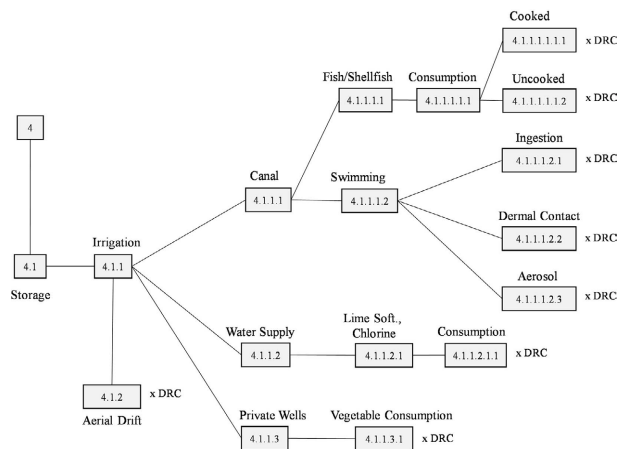

Figure 8. Reuse irrigation risk tree diagram (from [2]).

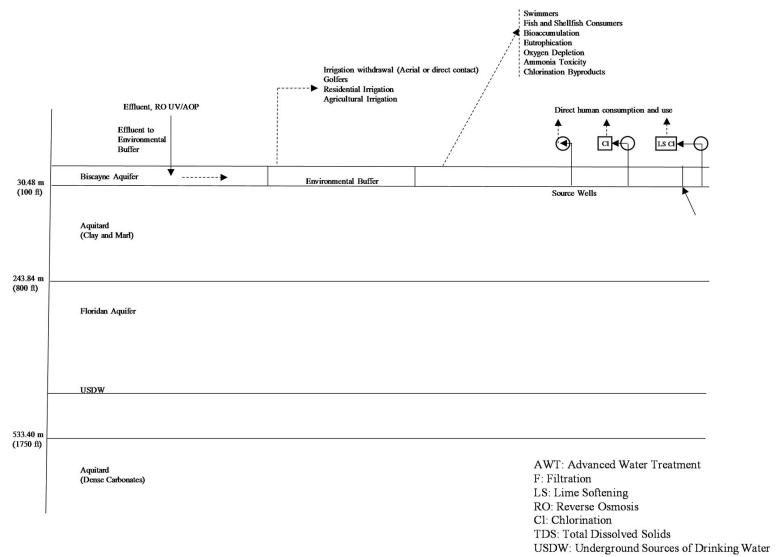

Figure 9. Indirect potable reuse aquifer injection disposal method route diagram (from [2]).

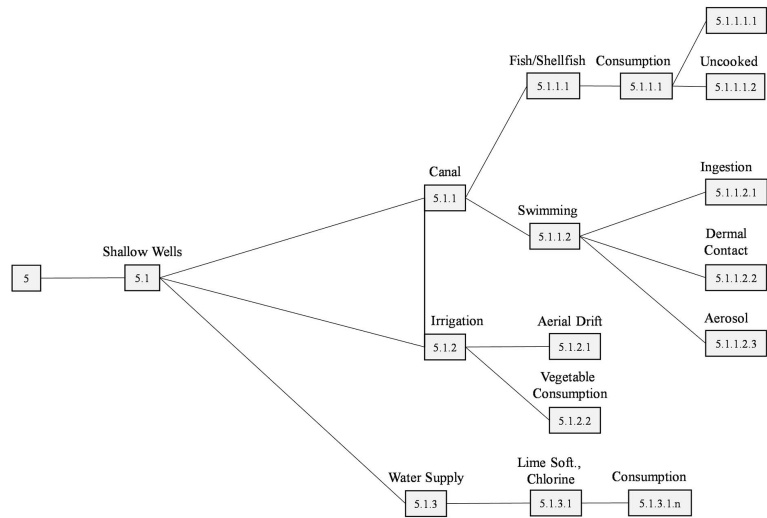

Figure 10. Indirect potable reuse aquifer injection risk tree diagram from [1]).

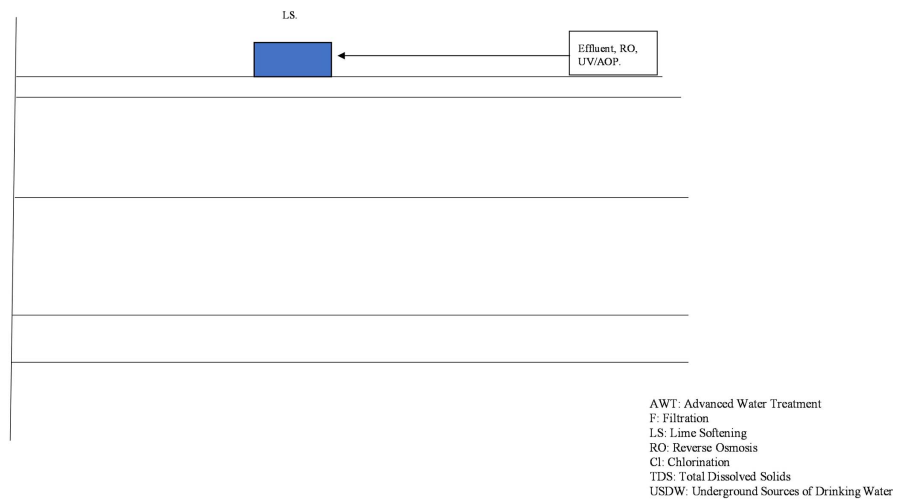

Figure 11. Potable reuse disposal method route diagram (from [1]).

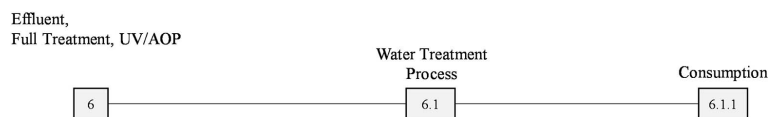

Figure 12. Potable reuse risk tree diagram (from [1]).

Contaminants of Concern

Initial discussions among the experts focused on the conceptual models discussed above for the technological and environmental setting for wastewater disposal in Southeast Florida. An extensive literature review was gathered and discussions about contaminants of concern were held. “Risk” for this study was defined in terms of the number and duration of periods when public health exposure triggers were exceeded, projected for each alternative. The following public health exposure triggers were used [1]:

- 1) Rotavirus—zero CFU/mL (based on Bloetscher [25] and team microbiolo-

gists)

2) PFAS—5 ng/L (per California law—note this effort was conducted before the USEPA proposed 4 ng/L regulation)

3) Total Phosphorous—10 mg/L environmental exposure (as used in both prior studies)

4) 17 β estradiol—0.5 ng/L—the known impact on fish

While these were used for Bloetscher *et al.* [1], local conditions may dictate what public health concerns might be appropriate. Norovirus has been suggested as a replacement for rotavirus [13]. A different microbiological agent might be considered in other jurisdictions such as fecal or total coliforms which are faster to detect. Caffeine, ibuprofen and acetaminophen are also options to contaminants.

Expert opinion can be solicited for input on the model developed using a modified Delphi method. The modified Delphi method used in the UM and FAU studies is described in Bloetscher *et al.* [1] [23]. The Delphi technique is a methodology developed by the Rand Corporation in 1948 to elicit expert opinion in a systematic way in order to gather subjective information as data. Apostalakis [26] anticipated that the use of expert opinions in safety studies and risk management would receive increased attention. The benefits of a Delphi solicitation are that it is generally fast, inexpensive, easy to understand, versatile, and can be applied wherever expert opinion is believed to exist [27]. The method used in this study was a modified version of Delphi, aimed at obtaining a distribution of opinions rather than consensus, and with experts answering questionnaires individually rather than as a group.

For the modified Delphi each node and each discharge alternative, the research team was asked four questions:

1) How many times in 30 years will the public health exposure trigger be exceeded at the receiving node? (One such exceedance event may last any number of days.)

2) What is your confidence in the numbers of exceedance events you entered? Please select low (L), medium (M) or high (H).

3) How many days will exceedance events last (minimum, mean, maximum)?

4) What is your confidence in the event sizes you entered? Please select from low (L), medium (M) or high (H).

For each disposal option and each constituent, the results calculated for each node were added to obtain an overall believed number of days as a percentage of the total timeframe of 10,950 days (30 years). The means for creating these results was based on obtaining the probability distribution for risks and developing a robust risk assessment is described by Shannon [28]: “The probability distribution having maximum entropy (uncertainty) over any finite range of real values is the uniform distribution over that range.” Predictive Bayesian inference is one means of addressing the challenge of assessing uncertainty in risk estimation and has been previously applied [29] [30] [31] [32] [33]. The approach, successful in previous projects, involves the assignment of probability distribu-

tions, termed *sampling distributions*, to uncertain/variable parameters affecting the risk of a planning alternative.

The Poisson distribution is known to predict the number of incidents over a period [34]. The Pareto distribution is known to predict incident size ([23] [29] [30] [31] [32] [35]). Probability distributions, termed *prior distributions*, can then be assigned to the parameters of the sampling distributions. The predictive Bayesian approach used here is identical to that from the UM study [20].

Incidents have been suggested to be represented as Poisson distributions [23] [30] [31] [32] [33]. A Poisson distribution is a discrete distribution that can be used to model rare-events with a gamma prior distribution for λ [36]. Using this method, **Table 3** shows the results of the programs for the south Florida example (run for reach node). Ultimately, the injection wells and direct potable reuse options were the lowest risk. The similarity in risk from these two options was unanticipated but, these low relative risks are likely due to the advanced treatment used for direct potable reuse and the lack of public exposure.

3. Results

Reviewing the results of the FAU study provides some insight into the simplification of the process. First, very few places will have 6 available alternatives, thereby simplifying the process considerably. In addition, not all nodes are significant. In **Table 3**, the red items indicate the expert opinion is less than the minimum of 10^{-9} . As a result, they can be ignored since they fall below the minimum risk permitted in the study (10^{-9}). The orange boxes indicate risk exposures that are less than 1% contributions. As a result, they can also likely be ignored. Yellow boxes are 10 times less and therefore probably should not be ignored. **Figures 13-18** show each of the decision trees with the important risks highlighted. This can greatly simplify the analysis particularly as an initial analysis that does not require the extensive literature review and data gathering an expert opinion might need. As noted in **Figures 13-18**, the process simplifies considerably when many nodes are not required.

The modified Delphi can also be created at two levels. For starting purposes at the local level, a staff can use the models to develop “what if” scenarios and measure the breadth of uncertainty. However, to conduct a public-facing study, experts should be employed.

During the FAU study [1], for most of the options, there was a node or two that carried the weight many times others were far lower magnitudes and can probably be ignored. For example, the injection wells nodes of significant public health exposure were ASR wells that did not treat the water (a finding from [23]). For ocean outfalls, the issue was beach swimming. The exposure pathway can vary considerably—in south Florida, no one is really swimming in the canals, but this may not be true in places where the water is more recreation (Texas) or high quality waters (Colorado mountains, N. England). As the options may vary, the need to pursue options varies as well. Likewise, data on contaminants needs careful consideration. PFAS data was too scattered to provide a

Table 3. Comparison of total believed days failing to meet trigger over 30 years to other options (from Bloetscher, *et al.* 2024).

Rotavirus	Contaminant	Ocean Outfalls	Surface	Irr Reuse	Indirect Potable Reuse	Potable Reuse
Injection Wells	Rotavirus	6E+00	2E+01	2E+01	3E+00	7E-01
	PFAS	4E+01	3E+01	4E+01	4E+00	4E+00
	Total Phosphorous	4E+00	4E+00	6E+00	3E+00	3E-01
	Estrogen	3E+01	1E+01	2E+01	3E+00	6E-01
Ocean Outfalls	Rotavirus		3E+00	4E+00	5E-01	1E-01
	PFAS		8E-01	1E+00	1E-01	1E-01
	Total Phosphorous		1E+00	2E+00	7E-01	7E-02
	Estrogen		4E-01	5E-01	8E-02	2E-02
Surface	Rotavirus			1E+00	2E-01	3E-02
	PFAS			1E+00	1E-01	1E-01
	Total Phosphorous			2E+00	7E-01	7E-02
	Estrogen			1E+00	2E-01	5E-02
Irr Reuse	Rotavirus				1E-01	3E-02
	PFAS				1E-01	9E-02
	Total Phosphorous				4E-01	4E-02
	Estrogen				2E-01	4E-02
Direct Potable Reuse	Rotavirus					2E-01
	PFAS					8E-01
	Total Phosphorous					1E-01
	Estrogen					2E-01

*Negative exponent indicates the risk numerator is lower disposal option than the denominator disposal option.

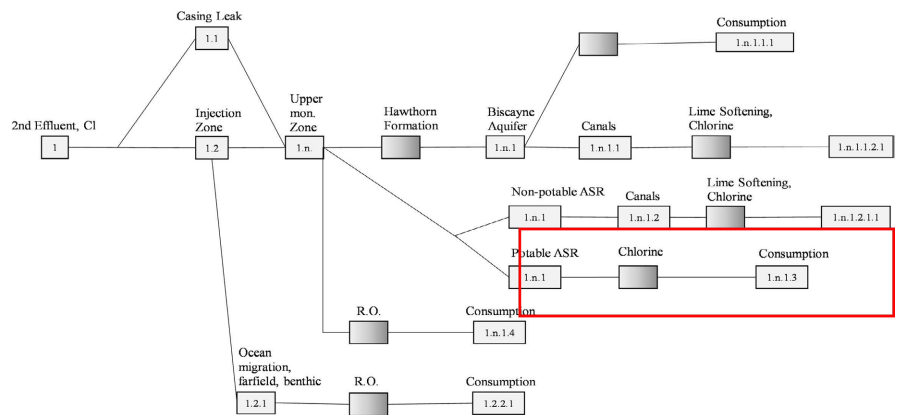

Figure 13. Significant nodes for injection wells.

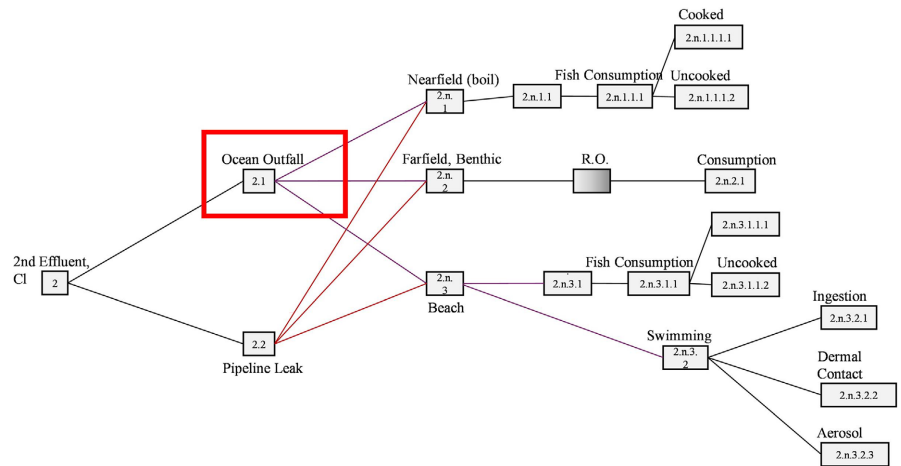

Figure 14. Significant nodes for ocean outfall discharges.

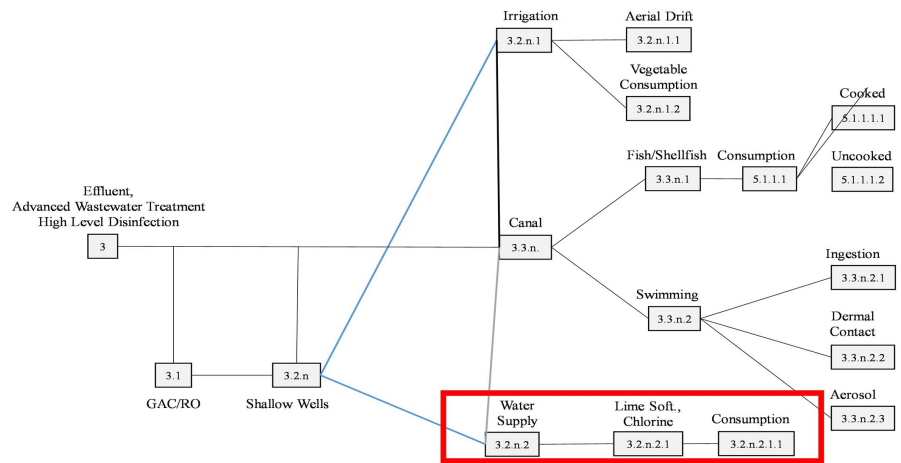

Figure 15. Significant exposure nodes for Cana/surface water discharges.

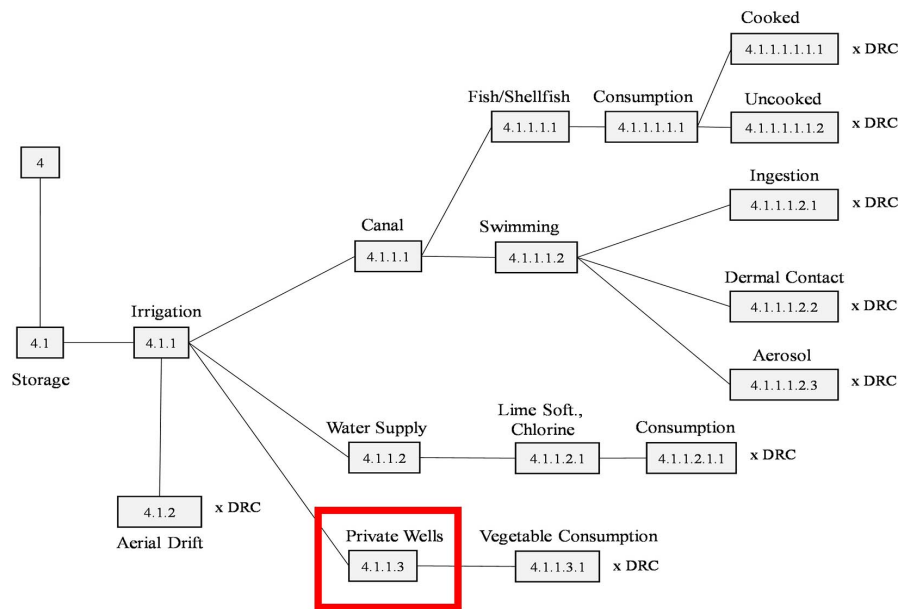

Figure 16. Significant exposure nodes for reuse irrigation.

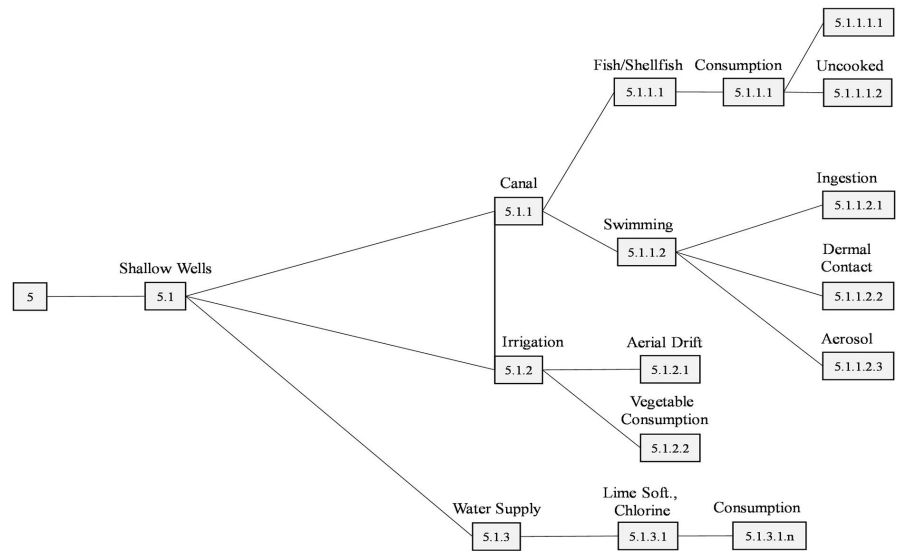

Figure 17. Significant exposure nodes for indirect potable reuse.

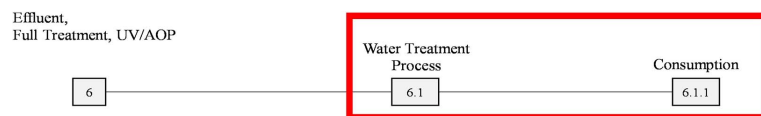

Figure 18. Significant exposure nodes for direct potable reuse.

good answer, the FAU study did not have enough data to really evaluate this properly. Nutrient pathways are not really an issue in south Florida, but they are in other communities with the caveat of whether they are ecological or public health impacts? Surrogates for nutrients, like cyanobacteria might be useful for ecological risks.

Development of the initial process would include asking a series of question to reduce the number of scenarios offered:

- 1) Do you have access to ocean disposal?
- 2) Do you have access to Class I injection zone available for disposal?
- 3) Do you need to use reclaimed water for water supply purposes?
- 4) Do you make snow for skiing using wastewater (or might you)?
- 5) Are there recreational uses downstream of your discharge point?
- 6) Is swimming in local waterways where wastewater is discharged a significant issue?
- 7) Is fish consumption from nearby waterways that receive wastewater disposal significant in your community?

Many nodes can be excluded at this point.

The process to develop such a tool is outlined as follows:

- 1) Challenges to overcome
 - a) Direct comparisons
 - b) Localized effort requires a lot of time from experts
 - c) Finding experts
 - d) Simplifying the process

Table 4. Summary of Modeling Results by node and constituent.

	Injection Well		Ocean Outfall		Surficial Recharge		Reuse Irrigation		Indirect Potable Reuse		Direct Potable Reuse	
Rotavirus	1.n.1.1.1	2.71E-13	2.n.2.1	2.10E-12	3.2.n.1.1	6.40E-11	4.1.2	6.80E-08	5.1.3.1.n	1.33E-07	6.1.1	7.80E-10
	1.n.1.1.2.1	5.01E-12	2.n.1.1.1.1	8.31E-13	3.2.n.1.2	7.81E-08	4.1.1.1.1.1.1	2.32E-07	5.1.1.1.1	8.23E-07		
	1.n.1.2.1.1	4.39E-12	2.n.1.1.1.2	2.03E-07	3.3.n.1.1.1	2.22E-08	4.1.1.1.1.1.2	5.95E-08	5.1.1.1.2	3.97E-09		
	1.n.1.3	2.23E-11	2.n.3.2.1	3.54E-06	3.3.n.1.1.2	5.12E-07	4.1.1.1.1.2.1	5.11E-07	5.1.1.2.1	5.93E-08		
	1.n.1.4	6.24E-13	2.n.3.2.2	6.18E-08	3.3.n.2.1	7.07E-08	4.1.1.1.1.2.2	1.92E-06	5.1.1.2.2	3.26E-07		
	1.n.1.1.1.1	6.70E-12	2.n.3.2.3	1.11E-06	3.3.n.2.2	3.45E-09	4.1.1.1.1.2.3	4.73E-07	5.1.1.2.3	2.85E-06		
	1.n.1.2	2.10E-12	2.n.3.1.1.1	7.55E-07	3.3.n.2.3	1.73E-09	4.1.1.3.2	9.90E-07	5.1.2.1	2.55E-07		
	1.2.1	4.58E-09	2.n.3.1.1.2	4.58E-07	3.2.n.2.1.1	1.38E-07	4.1.1.3.1	7.52E-07	5.1.2.2	2.20E-07		
	1.2.1.1	6.53E-13	2.1	4.94E-06			4.1.1.3	3.13E-07				
		2.n.2	6.42E-07									
Summation of Delphi: 4.62353E-09		1.1708E-05		8.26123E-07		5.31489E-06		4.66852E-06		7.7982E-10		
PFAS	1.n.1.1.1	1.00E-11	2.n.2.1	9.77E-08	3.2.n.1.1	8.41E-11	4.1.2	1.75E-07	5.1.3.1.n	6.80E-07	6.1.1	3.43E-06
	1.n.1.1.2.1	3.66E-11	2.n.1.1.1.1	1.80E-06	3.2.n.1.2	8.24E-07	4.1.1.1.1.1.1	5.62E-07	5.1.1.1.1	1.49E-07		
	1.n.1.2.1.1	1.08E-08	2.n.1.1.1.2	6.64E-07	3.3.n.1.1.1	1.14E-06	4.1.1.1.1.1.2	5.04E-06	5.1.1.1.2	1.41E-09		
	1.n.1.3	1.17E-08	2.n.3.2.1	8.56E-08	3.3.n.1.1.2	6.48E-07	4.1.1.1.1.2.1	1.14E-06	5.1.1.2.1	2.82E-08		
	1.n.1.4	2.91E-09	2.n.3.2.2	1.15E-06	3.3.n.2.1	9.88E-06	4.1.1.1.1.2.2	1.96E-07	5.1.1.2.2	2.12E-11		
	1.n.1.1.1.1	4.41E-11	2.n.3.2.3	1.71E-11	3.3.n.2.2	5.32E-08	4.1.1.1.1.2.3	1.24E-07	5.1.1.2.3	1.69E-10		
	1.n.1.2	1.70E-12	2.n.3.1.1.1	2.23E-06	3.3.n.2.3	4.23E-11	4.1.1.3.2	9.72E-09	5.1.2.1	5.79E-11		
	1.2.1	1.00E-12	2.n.3.1.1.2	9.79E-06	3.2.n.2.1.1	4.57E-06	4.1.1.3.1	2.60E-06	5.1.2.2	5.31E-10		
	1.2.1.1	1.77E-11	2.1	5.36E-06			4.1.1.3	5.74E-06				
		2.n.2	5.99E-06									
Summation of Delphi: 2.55799E-08		2.71685E-05		1.71189E-05		1.558E-05		8.59003E-07		0.000003429		
TP	1.n.1.1.1	2.64E-09	2.n.2.1	2.36E-12	3.2.n.1.1	5.03E-09	4.1.2	5.95E-08	5.1.3.1.n	1.40E-09	6.1.1	1.96E-10
	1.n.1.1.2.1	2.79E-12	2.n.1.1.1.1	4.61E-11	3.2.n.1.2	6.69E-09	4.1.1.1.1.1.1	7.41E-09	5.1.1.1.1	1.56E-10		
	1.n.1.2.1.1	7.57E-13	2.n.1.1.1.2	6.13E-10	3.3.n.1.1.1	3.51E-08	4.1.1.1.1.1.2	2.40E-09	5.1.1.1.2	1.44E-07		
	1.n.1.3	1.55E-09	2.n.3.2.1	1.38E-07	3.3.n.1.1.2	3.31E-09	4.1.1.1.1.2.1	3.78E-09	5.1.1.2.1	6.07E-10		
	1.n.1.4	1.57E-10	2.n.3.2.2	3.44E-11	3.3.n.2.1	1.40E-08	4.1.1.1.1.2.2	4.22E-10	5.1.1.2.2	5.75E-09		
	1.n.1.1.1.1	7.80E-12	2.n.3.2.3	6.40E-12	3.3.n.2.2	4.91E-09	4.1.1.1.1.2.3	1.18E-08	5.1.1.2.3	1.02E-08		
	1.n.1.2	2.78E-11	2.n.3.1.1.1	2.31E-11	3.3.n.2.3	1.33E-09	4.1.1.3.2	5.39E-09	5.1.2.1	2.79E-08		
	1.2.1	4.02E-11	2.n.3.1.1.2	8.37E-11	3.2.n.2.1.1	2.67E-06	4.1.1.3.1	6.53E-08	5.1.2.2	2.58E-07		
	1.2.1.1	7.25E-11	2.1	1.40E-07			4.1.1.3	1.33E-07				
		2.n.2	1.70E-07									
Summation of Delphi: 4.50241E-09		4.49269E-07		2.73742E-06		2.89233E-07		4.47737E-07		1.9614E-10		

Continued

	Injection Well	Ocean Outfall	Surficial Recharge	Reuse Irrigation	Indirect Potable Reuse	Direct Potable Reuse
	1.n.1.1.1 9.03E-13	2.n.2.1 4.87E-07	3.2.n.1.1 9.69E-07	4.1.2 1.74E-08	5.1.3.1.n 8.84E-08	6.1.1 2.09E-08
	1.n.1.1.2.1 4.44E-13	2.n.1.1.1.1 3.97E-06	3.2.n.1.2 5.43E-08	4.1.1.1.1.1.1 6.97E-08	5.1.1.1.1 3.73E-07	
	1.n.1.2.1.1 4.33E-12	2.n.1.1.1.2 1.99E-05	3.3.n.1.1.1 8.45E-07	4.1.1.1.1.1.2 6.45E-07	5.1.1.1.2 5.90E-11	
	1.n.1.3 6.90E-09	2.n.3.2.1 7.70E-07	3.3.n.1.1.2 7.00E-08	4.1.1.1.1.2.1 2.23E-07	5.1.1.2.1 3.73E-09	
Synthetic Estrogen	1.n.1.4 3.97E-11	2.n.3.2.2 2.27E-06	3.3.n.2.1 2.73E-08	4.1.1.1.1.2.2 7.74E-07	5.1.1.2.2 3.90E-11	
Synthetic Estrogen	1.n.1.1.1.1 1.33E-09	2.n.3.2.3 4.84E-10	3.3.n.2.2 6.41E-06	4.1.1.1.1.2.3 5.40E-08	5.1.1.2.3 1.40E-10	
	1.n.1.2 2.66E-12	2.n.3.1.1.1 2.15E-06	3.3.n.2.3 3.39E-07	4.1.1.3.2 1.14E-07	5.1.2.1 1.18E-10	
	1.2.1 1.09E-11	2.n.3.1.1.2 4.03E-07	3.2.n.2.1.1 1.44E-06	4.1.1.3.1 1.10E-06	5.1.2.2 1.05E-10	
	1.2.1.1 1.58E-12	2.1 3.42E-06		4.1.1.3 2.66E-07		
		2.n.2 1.14E-07				
Summation of Delphi:	8.28879E-09	3.34792E-05	1.01592E-05	3.26331E-06	4.65863E-07	2.0895E-08

- i) How to eliminate nodes (and maybe some are gone to start)
- ii) Identify nodes that are locally relevant
- e) Identify treatment requirements that apply
- 2) Create a two track excel based program
 - a) Your options
 - b) Your treatment
 - c) Your WQ concerns
 - d) Your pathways
 - e) Track 1—the primary driver only (Staff based)
 - f) Track 2—experts—may include others nodes deemed relevant by experts
 - i) How to find the experts or is that us? Need local help as well
 - g) Include all nodes but “zero” out the unneeded ones
 - h) Develop a process to solicit responses from experts

For a more formal process, expert opinion and data are needed. It is suggested that all yellow, and likely many orange nodes on **Table 4** should be retained, at least initially. Finding the experts is one challenge as some knowledge of local conditions and regulatory contacts is also relevant.

4. Conclusions

The FAU [1] and UM [20] studies provide a pathway to an informed risk assessment process of wastewater disposal and reuse options. While the FAU and UM studies are limited to south Florida, the methods can be translated elsewhere. The ability to limit options and nodes reduces the effort required considerably. In comparing the FAU study to this effort, eliminating the red, orange and yellow boxes in **Table 4**, created minimal impact and no changes in the magnitude of difference between options. Hence the concept has potential.

Note this effort is not intended to address risks associated with issues in the water distribution systems. Such problems are not related to the wastewater dis-

posal options. The public's perception of wastewater treatment and reclaimed water also is not something measurable. A public relations effort is needed to address the public's perception of the "Toilet to Tap" concern.

Conflicts of Interest

The authors declare no conflicts of interest regarding the publication of this paper.

References

- [1] Bloetscher, F., Meeroff, D.E., Conboy, K., Sham, C.H., Gergen, R.E., Gallant, R., Hart, J., Muniz, A., Shibata, T., Tuccillo, M.E. and Englehardt, J.D. (2024) Assessing Relative Risks of Municipal Wastewater Disposal Options for Southeast Florida. *Risk Analysis*. <https://doi.org/10.1111/risa.14301>
- [2] Muñoz, I., Gómez-Ramos, M. J., Agüera, A., Fernández-Alba, A.R., García-Reyes, J. F. and Molina-Díaz, A. (2009) Chemical Evaluation of Contaminants in Wastewater Effluents and the Environmental Risk of Reusing Effluents in Agriculture. *TrAC Trends in Analytical Chemistry*, **28**, 676-694. <https://doi.org/10.1016/j.trac.2009.03.007>
- [3] Compagni, R.D., Gabrielli, M., Polesel, F., Turolla, A., Trapp, S., Vezzaro, L. and Antonelli, M. (2020) Risk Assessment of Contaminants of Emerging Concern in the Context of Wastewater Reuse for Irrigation: An Integrated Modelling Approach. *Chemosphere*, **242**, Article ID: 125185. <https://doi.org/10.1016/j.chemosphere.2019.125185>
- [4] Díaz-Garduño, B., Pintado-Herrera, M.G., Biel-Maeso, M., Rueda-Márquez, J.J., Lara-Martín, P.A., Perales, J.A., Manzano, M.A., Garrido-Pérez, C. and Martín-Díaz, M.L. (2017) Environmental Risk Assessment of Effluents as a Whole Emerging Contaminant: Efficiency of Alternative Tertiary Treatments for Wastewater Depuration. *Water Research*, **119**, 136-149. <https://doi.org/10.1016/j.watres.2017.04.021>
- [5] Rish, W.R. (2005) A Probabilistic Risk Assessment of Class I Hazardous Waste Injection Wells. *Underground Injection Science and Technology*, **52**, 93-135. [https://doi.org/10.1016/S0167-5648\(05\)52010-0](https://doi.org/10.1016/S0167-5648(05)52010-0)
- [6] Sloss, E.M., Geschwind, S.A., McCaffrey, and Ritz, B.R. (1996) Groundwater Recharge with Reclaimed Water: An Epidemiologic Assessment in Los Angeles County, 1987-1991. RAND, Santa Monica.
- [7] Reynolds, K.A. (2000) Human Viruses Found in Groundwater Recharge Sites. *Water Conditioning and Purification*, **42**, 148-150.
- [8] Link, M., Von Der Ohe, P.C., Voß, K. and Schäfer, R.B. (2017) Comparison of Dilution Factors for German Wastewater Treatment Plant Effluents in Receiving Streams to the Fixed Dilution Factor From Chemical Risk Assessment. *Science of the Total Environment*, **598**, 805-813. <https://doi.org/10.1016/j.scitotenv.2017.04.180>
- [9] Amoueyan, E., Ahmad, S., Eisenberg, J.N.S., Pecson, B. and Gerrity, D. (2017) Quantifying Pathogen Risks Associated with Potable Reuse: A Risk Assessment Case Study for Cryptosporidium. *Water Research*, **119**, 252-266. <https://doi.org/10.1016/j.watres.2017.04.048>
- [10] Choudri, B.S., Charabi, Y. and Ahmed, M. (2018) Health Effects Associated with Wastewater Treatment, Reuse and Disposal. *Water Environment Research*, **90**, 1759-1776. <https://doi.org/10.2175/106143018X15289915807425>
- [11] Soller, J.A., Eftim, S.E. and Nappier, S.P. (2018) Direct Potable Reuse Microbial Risk

- Assessment Methodology: Sensitivity Analysis and Application to State Log Credit Allocations. *Water Research*, **128**, 286-292.
<https://doi.org/10.1016/j.watres.2017.10.034>
- [12] Purnell, S., Halliday, A., Newman, F., Sinclair, C. and Ebdon, J. (2020) Pathogen Infection Risk to Recreational Water Users, Associated with Surface Waters Impacted by de Facto and Indirect Potable Reuse Activities. *Science of the Total Environment*, **722**, Article ID: 137799. <https://doi.org/10.1016/j.scitotenv.2020.137799>
- [13] Soller, J.A., Eftim S.E. and Nappier, S.P. (2019) Comparison of Predicted Microbiological Human Health Risks Associated with de Facto, Indirect, and Direct Potable Water Reuse. *Environmental Science & Technology*, **53**, 13382-13389.
<https://doi.org/10.1021/acs.est.9b02002>
- [14] Tanaka, H., Takashi, A., Schroeder, E.D. and Tchobanoglous, G. (1998) Estimating the Safety of Wastewater Reclamation and Reuse Using Enteric Virus Monitoring Data, *Water Environment Research*, **70**, 39-51.
<https://doi.org/10.2175/106143098X126874>
- [15] Gerba, C.P. and Rose, J. (1983) Estimating Viral Disease Risk from Drinking Water. In: Cothorn, C.R., Ed., *Comparative Environmental Risk Assessment*, Lewis Publishers, Boca Raton, 117-135.
- [16] Hutzler, N.J. and Boyle, W.C. (1982) Risk Assessment in Water Reuse, In: Middlebrooks, E.J., Ed., *Water Reuse*, Ann Arbor Science Publishers, Ann Arbor.
- [17] Hutzler, N.J. and Boyle, W.C. (1980) Wastewater Risk Assessment. *Journal of Environmental Engineering*, **106**, 919. <https://doi.org/10.1061/JEEGAV.0001098>
- [18] Regli, S., Pore, J.B., Haas, C.N. and Gerba, C.P. (1991) Modeling the Risk from *Giardia* and Viruses in Drinking Water. *Journal of the American Water Works Association*, **83**, 76-84. <https://doi.org/10.1002/j.1551-8833.1991.tb07252.x>
- [19] Asano, T. and Sakaji, R. (1990) Virus Risk Analysis in Wastewater Reclamation and Reuse. In: Hahn, H.H. and Klute, R., Eds., *Chemical Water and Wastewater Treatment*, Springer-Verlag, Berlin, 483-496.
https://doi.org/10.1007/978-3-642-76093-8_32
- [20] Englehardt, J.D., Amy, V.P., Bloetscher, F., Chin, D.A., Fleming, L.E., Gokgoz, S., Solo-Gabriele, H., Rose, J.B., and Tchobanoglous, G. (2001) Comparative Assessment of Human and Ecological Impacts for Municipal Wastewater Disposal Methods in Southeast Florida: Deep Wells, Ocean Outfalls, and Canal Discharges. University of Miami, Coral Gables.
- [21] Bloetscher, F. (2003) The Impact of Location of ASR Wells on Deep Well Risk Assessment. *AWWA Source Water Protection Conference—Albuquerque*, NM, January, 2003.
- [22] Bloetscher, F. (2002) The Risk Impact of Class 1 Injection Wells on ASR Wells. *Annual Forum of the Groundwater Protection Council*, San Francisco, CA, September 2002.
- [23] Bloetscher, F., Englehardt, J.D., Chin, D.A., Rose, J.B., Tchobanoglous, G., Amy, V.P. and Gokgoz, S. (2005) Comparative Assessment Municipal Wastewater Disposal Methods in Southeast Florida. *Water Environment Research*, **77**, 480-490.
<https://doi.org/10.2175/106143005X67395>
- [24] Englehardt, J.D. (1997) Bayesian Benefit-Risk Analysis for Sustainable Process Design. *Journal of Environmental Engineering*, **123**, 71-78.
[https://doi.org/10.1061/\(ASCE\)0733-9372\(1997\)123:1\(71\)](https://doi.org/10.1061/(ASCE)0733-9372(1997)123:1(71))
- [25] Bloetscher, F. (2001) A Risk Management Model for Finding Minimum Distance Requirements to Meet Reasonable Assurance of No Negative Impacts on Potable

- Water Supply Wells from Alternative Injection Well Programs. Ph.D. Thesis, University of Miami, Coral Gables.
- [26] Apostolakis, G. (1990) The Concept of Probability in Safety Assessments of Technological Systems. *Science*, **250**, 1359-1364. <https://doi.org/10.1126/science.2255906>
- [27] Sackman, H. (1975) *Delphi Critique: Expert Opinion, Forecasting, and Group Process*. Lexington Books, Lexington Mass.
- [28] Shannon, C.E. (1949) *The Mathematical Theory of Communication*. The University of Illinois Press, Urbana.
- [29] Jarabek, A. and Hasselblad, V. (1990) Inhalation Reference Concentration Methodology: Impact of Domestic Adjustments and Future Directions Using the Confidence Profile Methods. *84th Annual Meeting and Exhibition of the Air and Waste Management Association*, Vancouver, June 1984, Article No. 91-173.3.
- [30] Englehardt, J.D. and Lund, J. (1993) Information Theory in Risk Analysis. *Journal of Environmental Engineering*, **118**, 890-904. [https://doi.org/10.1061/\(ASCE\)0733-9372\(1992\)118:6\(890\)](https://doi.org/10.1061/(ASCE)0733-9372(1992)118:6(890))
- [31] Englehardt, J.D. and Swartout, P. (2006) Predictive Bayesian Microbial Dose-Response Assessment Based on Suggested Self-Organization in Primary Illness Response: *Cryptosporidium Parvum*. *Risk Analysis*, **26**, 543-554. <https://doi.org/10.1111/j.1539-6924.2006.00745.x>
- [32] Englehardt, J. (1995) Predicting Incident Size from Limited Information. *Journal of Environmental Engineering*, **121**, 455-464. [https://doi.org/10.1061/\(ASCE\)0733-9372\(1995\)121:6\(455\)](https://doi.org/10.1061/(ASCE)0733-9372(1995)121:6(455))
- [33] Bloetscher, F. (2019) Using Predictive Bayesian Monte Carlo-Markov Chain Methods to Provide a Probabilistic Solution for the Drake Equation. *Acta Astronautica*, **155**, 118-130. <https://doi.org/10.1016/j.actaastro.2018.11.033>
- [34] Ross, S.M. (1985) *Introduction to Probability Models*. 3rd Edition, Academic Press, San Diego.
- [35] Press, S.J. (1989) *Bayesian Statistics: Principles, Models and Applications*. John Wiley & Sons, New York.
- [36] Aitchison, J. and Dunsmore I.R. (1975) *Statistical Prediction Analysis*. Cambridge University Press, Cambridge. <https://doi.org/10.1017/CBO9780511569647>