

Complications Faced by Disabled Students at Higher Education Institutions in Bangladesh: Observations from Nondisabled Students

Harun Ar-Rashid Mamun¹, Md. Mashiur Rahman^{2*}, Mohammad Al-Amin³, Md. Moin Uddin Erfan³, Saydur Rahman³, Rokeya Akter³

¹BRAC Institute of Educational Development (BRAC IED), BRAC University, Dhaka, Bangladesh

²Professional Teacher Education, Tampere University of Applied Sciences (TAMK), Tampere, Finland

³Department of Public Administration, Comilla University, Comilla, Bangladesh

Email: *mashiur_rahman1982@cou.ac.bd

How to cite this paper: Mamun, H. A.-R., Rahman, Md. M., Al-Amin, M., Erfan, Md. M. U., Rahman, S., & Akter, R. (2024). Complications Faced by Disabled Students at Higher Education Institutions in Bangladesh: Observations from Nondisabled Students. *Open Journal of Social Sciences*, 12, 413-439.

<https://doi.org/10.4236/jss.2024.124029>

Received: March 18, 2024

Accepted: April 22, 2024

Published: April 25, 2024

Copyright © 2024 by author(s) and Scientific Research Publishing Inc.

This work is licensed under the Creative Commons Attribution International License (CC BY 4.0).

<http://creativecommons.org/licenses/by/4.0/>



Open Access

Abstract

A large proportion of the disabled population in Bangladesh does not have access to education. In addition, in the case of higher education, this number is very insignificant. All these disabled students have stories of struggle to reach university. Moreover, almost all the educational opportunities for the disabled at the government or private level are up to the primary or secondary level. But learning is very difficult for the disabled unless they have a very strong will. Therefore, the purpose of this study was to measure nondisabled students' perceptions of problems faced by disabled students at higher educational institutions (HEIs) in Bangladesh. The study findings suggest that there is a negative impact of academic problems faced by disabled students pursuing higher education. It was also found that the infrastructural settings of HEIs are not friendly for disabled students, and most of them also face financial crises. Furthermore, the study found that most of the disabled students of HEIs did not get enough support from families, classmates, and teachers and they also experienced social obstacles. However, the study findings will help policymakers and educational institutions to create a more inclusive and effective disable friendly environment at educational institutions in future.

Keywords

Complications, Disabled Students, Higher Education, Learning Environment, Nondisabled Students, Bangladesh

1. Introduction

Education is critical for everyone, irrespective of age, sex, color, socioeconomic

situation, or physical capabilities or impairment; individuals, particularly pupils with physical impairments, are frequently seen as disadvantaged groups by society (Block, 1992, as cited in Kabuta, 2014). The term “universal education” is not limited to prosperous countries; it is also used in developing countries. Bangladesh is a developing country that is progressively advancing toward free public education (Ahsan & Burnip, 2007). Bangladesh’s government has consistently devised strategies and initiatives to educate more children with impairments (Kibria, 2005). The education system has been defined in a variety of ways. Practically, ubiquitous, and accessible methods for teaching physically challenged students in ordinary classes with other students instead of segregating them in particular classrooms (Westwood, 2013). Particularly UNESCO concentrates on universal education at the public university level, and the government has taken many initiatives to ensure education for all people to achieve quality education, which is an inclusive goal of the SDGs. The Government of Bangladesh (GOB) has vowed to achieve its aim of universal education (Islam, 2010, as cited in Rahman, 2021). According to the BBS, in Bangladesh, 40.29% of students with disabilities are enrolled in different education levels; however, only 2.72% of disability students have passed or are registered in HSC or postsecondary learning (The Business Standard, 2023). Bangladesh’s People with Disabilities Rights and Protection Act of 2013 gave handicapped individuals access to learning and availability. The architectural atmosphere should be created in such a way that the process of learning is enjoyable. The academic system provides physically disabled students with wonderful sentiments (Hussein, 2012). The Jahangirnagar University Act of 1973 stipulated that all candidates be qualified to apply, and 15 physically handicapped pupils are accepted on a quota system per year (Rahman, 2021).

Higher education has changed dramatically during the last two decades (Marginson, 2016). Higher education institutions (HEIs) are locations where students come at a critical juncture in their lives, one that necessitates the development of a distinct personality, students with impairments must contend with dual challenges of academic obligations and their handicaps; an obtainable educational system in which people with disabilities have equal access to their surroundings and are subject to the same duties and functions as everyone else, with respect and without hindrance (Saksena & Sharma, 2015). Whereas female and black students’ enrollment has expanded, students with learning disabilities have received less consideration; therefore, students with abnormalities tend to be rejected from higher education (Howell, 2006, as cited in Mutanga, 2017). To ensure fair engagement in social and academic life, expanded entrance and supportive services are required at universities (Tugli, 2013). International legislation and agreements, such as the United Nations Convention on the Rights of Persons with Disabilities, have primarily encouraged all people to participate in society. Attempts to accommodate the learning requirements of students with a wide variety of abilities, from giftedness to intellectual disability, are referred to

as inclusion and can be performed only by adapting (where required) the methods in which instruction is arranged and presented in the classroom (Westwood, 2013). The main objective of our study was to determine the difficulties faced by disabled students at Bangladesh's higher education institutions. Because most public universities in Bangladesh enable physically challenged learners to study their premises, institutions of higher learning must be designed to welcome them.

2. Literature Review

Several studies have been undertaken by various scholars to explore the complications faced by disabled students in higher education. The following are some of the most notable studies in this field. Crous (2004), as cited in Mutanga (2017), outlined that few disabled persons attend postsecondary studies and those who encounter numerous hurdles. Additionally, Mutanga and Walker (2015), as cited in Mutanga (2017), noted that individuals with disabilities face a variety of conditions, including human, ecological, and financial factors; additionally, strategic factors have been overlooked. Conversely, a survey by Fichten et al. (2009), such as cited in Simui et al. (2017), explored inaccessible digital learning and inflexible course material and exams in the USA and Canada. Physically challenged students are unable to reach educational institutions due to a lack of accessible architectural structures (Dulal, 2003). Students' effectiveness in teaching at a HEI was impacted by structural facilities and layout (Natasha et al., 2012, as cited in Rahman, 2021). In Mexico, the right to participate in or access community settings, services, and opportunities, including work and recreation, is not guaranteed to people with disabilities (Skivington, 2011). In the Netherlands, people believe that they lack the necessary tools to successfully reach a workforce with a disability (Büscher-Touwen et al., 2018). Three years later, in Sweden, which is a developed country, universities provided limited support services to disabled students (Taneja-Johansson, 2024). Economic, ecological, diplomatic, and ideological barriers prevent students with disabilities from fully participating in higher education (Strnadová, Hájková, & Květoňová, 2015).

Several years later, Mutanga (2017) concluded that many obstacles are related to the curricula and supplementary teaching assistants and deprived of various social, educational, health, family, and political opportunities. Similarly, Fuller et al. (2004) noted that in the UK approximately 44% of disabled students face difficulties in learning systems in terms of writing and listening to lectures. Furthermore, Fuller et al. (2004) asserted that 17% of students with disabilities do not access information and technology; almost one-fifth of those experienced in the assessment of examinations and teachers are unhelpful. Similarly, Butler et al. (2017), as cited in Simui et al. (2017), noted the poor communication and interaction of teachers with them in Australia. In terms of skills, handicap happens when a person with a disability is denied the possibility and right to perform

tasks (Mitra, 2006). After that, during segregation, almost 80% of learners with abnormalities were disenfranchised from the educational system. In India, improved access and support services are required to ensure equity (Jameel, 2011). Four years later, Saksena and Sharma (2015) showed that students with disabilities were dissatisfied with the library treatment owing to limited accessible formats. A public university is controlled or financed by the federal government (Monem & Baniamin, 2010). A survey was conducted by the UK Government (2019), which revealed that facility inaccessibility prevents wheelchair users from fully integrating into campus life. Disabled students are not supported by families in using IT in the UK (Seale et al., 2015).

Because of the support of disability units, Matshedisho (2010) observed that 25% of students with impairments in his research felt comfortable and accepted throughout their transition into the institution. In Thailand, Bualar (2018) reported that the physical environment is unfavorable for individuals with disabilities, and unpleasant classes and exams can cause serious issues for blind learners. After three years, Zabeli et al. (2021) reported that a variety of obstacles were faced, including physical hurdles, inadequate support, and a lack of facilitation services inside the institution. In addition, Fuller et al. (2006) claimed that teaching methods are not appropriate for disabled students (50%) in the UK. According to the findings, approximately 40% of all infrastructures including classrooms, dormitories, ICT laboratories, language libraries, dining, administrative offices, washrooms, and playgrounds, were severely insufficient (Kabuta, 2014).

In the context of areas like Hong Kong SAR, Gilson and Dymond (2010) reported that the barriers faced by impaired students include those caused by the environment, infrastructure, policies, and attitudes. In a similar vein, Simui et al. (2020) explored Zambia's experience with unfavorable attitudes, an inaccessible learning environment and equipment, limited finances, and exam evaluation. Three years ago, Simui et al. (2017) showed that the learning environment is not comfortable for disabled students. Saksena and Sharma (2015) suggested that learners have conflicting responses to instructional staff behaviors, while others had unpleasant experiences. In South Africa, Lourens (2015) and Maguvhe (2015), as cited in Simui et al. (2017), found that the poor role of faculty members is to encourage and facilitate them. Similarly, Mutanga and Walker (2017) and Chhabra (2010), as cited in Simui et al. (2017), studied the lack of supportive and inclusive teaching and learning environments. Similarly, Ntombela and Soobrayen (2013), as cited in Simui et al. (2017) noted that minimal engagement occurs in academic functions. According to Morley and Croft (2011), disabled students do not participate equally and are treated negatively for both Ghana and Tanzania. The perspectives of students with disabilities are clearly emphasized in all the related research (Zhang et al., 2018). In Tanzania, Kabuta (2014) reported that stairs, narrow halls, high tables in laboratories and classrooms, and unsupportive facilities and toilets are infrastructure barriers.

Furthermore, Kabuta (2014) noted that students with physical disabilities lacked inclusion in their teachers' teaching and learning strategies. Jameel (2011) noted that more than half believe that external learning makes them vulnerable. In Zimbabwe, Kaputa (2013), as cited in Simui et al. (2017) outlined, learners with sight and hearing disabilities faced constraints in class materials. According to Matshediso's (2010) study, not all faculty members have a hostile perception of students with disabilities; it is crucial to recognize that others do. Tinklin and Hall (1999) and Pierce (1998), cited in Engelbrecht and de Beer (2014), revealed that access to the university's library was restricted for students with disabilities. People with learning disabilities should be motivated to engage in decision-making to address their unique needs (Mutanga, 2017). Insufficient resources and discrimination were investigated both in Uganda and Zambia (Eron, 2016; Muwana, 2012; as cited in Simui et al., 2017). In the same year, in India, the learning environment was not accessible, affordable, or efficient (Gill et al., 2017). Four years later, in Bhutan, female teachers had negative attitudes toward the topic rather than male teachers (Dorji et al., 2021). In Nepal, teachers with a lack of experience teach students with disabilities (Lamichhane, 2017). During the COVID-19 pandemic in Pakistan, compared to their counterparts without disabilities, students with disabilities experienced greater levels of stress (Nasir & Hameed, 2021). In that year, Ayub (2021) noted that infrastructures, such as libraries, classrooms, washrooms, canteens, and playgrounds, are not disabled friendly. In Bangladesh, Hosain et al. (2002) reported that disability had no noticeable effect on marital status (75.3%), career challenges (79.7%), family neglect (46.9%), or negative social treatment (39.2%). In contrast, Davis et al. (1992) noted that family and friends influence people to adopt technology in addition to other digital technology adventures. All the laws addressing disability in the United States, England, India, and Bangladesh have been evaluated (Rahman, 2021). Students with physical impairments have personal restrictions in the classroom that influence their social, psychological, and intellectual realms (Kabuta, 2014). Recently, in Bangladesh, Haider (2021) revealed that students with disabilities are supported by their families in using technology but do not receive extra facilities.

Therefore, Rahman and Akhtar (2020) conducted an in-depth study of specific accessibility-related barriers encountered by students with disabilities in higher education settings in Bangladesh, including challenges with the availability and effectiveness of physical infrastructure, digital resources, and assistive technology. Islam and Ali (2018) then took a closer look at the overall policy and legal structures governing the rights of persons with disabilities within the higher education sector in Bangladesh. They conducted an analysis to identify gaps and suggest potential areas for improvement to promote inclusivity. Furthermore, Khan and Siddique (2021) conducted a survey to assess the adequacy and effectiveness of tailored support services and accommodations for students with disabilities in selected universities in Bangladesh. Their findings point to specific

areas that could be improved to better serve this student population. Furthermore, [Akhter and Rahman \(2017\)](#) conducted an in-depth study of the financial barriers that prevent students with disabilities from pursuing higher education in Bangladesh. They explore challenges around assistive device affordability, healthcare spending and transportation costs, illuminating key areas of concern. Therefore, [Hossain and Islam \(2022\)](#) initiated a discussion around strategies to advance inclusive policies and practices within higher education institutions in Bangladesh. Their focus is to enhance the overall educational journey and outcomes of students with disabilities through targeted initiatives.

As mentioned earlier, the literature has identified disabled students' constraints in developed and developing countries, including Bangladesh. The present study investigated the responses of nondisabled students to the challenges of disabled students in Bangladesh. A literature review of the current research complications faced by disabled students focused on inaccessible infrastructural settings, limited financial support, negative treatment, lack of human and ecological support, unpleasant classrooms, washrooms, laboratories, and playgrounds, poor evaluation and poor access to IT sectors ([Nasir & Hameed, 2021](#); [Taneja-Johansson, 2024](#); [Simui et al., 2020](#); [Bualar, 2018](#); [Gill et al., 2017](#); [Mutanga, 2017](#); [Saksena & Sharma, 2015](#); [Kabuta, 2014](#); [Morley & Croft, 2011](#); [Fuller et al., 2004](#); [Dulal, 2003](#)). In addition, two previous studies ([Haider, 2021](#); [Kabuta, 2014](#)) were moderately related to the present study. However, no concrete research has been found in the Bangladeshi literature on the observation of nondisabled students toward the challenges of disabled students at HEIs. Considering this issue, the objective of the study is to determine the problems faced by students with disabilities at HEIs in Bangladesh.

3. Theoretical and Analytical Standpoints of the Study

3.1. Theoretical Understanding

Physical access is among the most significant problems for students with handicaps of experience in postsecondary learning. The following three issues will be addressed: the definition of disability; accessibility, inclusiveness, and engagement in university education; and fellow student support methods. The responsibility of caregiving for disabled individuals should be publicly acknowledged, properly allocated, and fairly rewarded, whatever other additional provisions are necessary for them to live a decent standard of living ([Mutanga, 2017](#)). This segregated teaching did not equip disabled students for further education because, for the most part, there was also no path after high school. There are very few systemic hurdles that prevent children from having disabilities, for example, from participating in academic programs.

One of the most relevant theoretical frameworks for understanding the complications faced by disabled students at higher education institutions is the Social Model of Disability. This model contrasts with the Medical Model of Disability, which views disability because of an individual's impairments or medical condi-

tions. In contrast, the Social Model posits that disability arises from the interaction between individuals with impairments and the social and physical environment that may present barriers to their full participation and inclusion (Oliver, 1990). According to the Social Model, disabled individuals are not inherently limited by their impairments but are instead disabled by societal attitudes, inaccessible environments, and discriminatory practices. Within higher education institutions, this framework helps elucidate the various barriers that disabled students may encounter, including physical accessibility issues, lack of accommodations, stigma, and discrimination (Shakespeare, 2006). Moreover, the Social Model emphasizes the importance of structural and systemic changes to address these barriers. This includes adopting inclusive policies, providing reasonable accommodations, and promoting universal design principles to ensure that educational environments are accessible to all students, regardless of their abilities (Barnes, 2012). By applying the Social Model of Disability, researchers and policymakers can better understand the multifaceted challenges faced by disabled students in higher education and work towards creating more inclusive and equitable learning environments.

3.2. Conceptual Framework of the Study

3.2.1. Learning Environment and Complications Faced by Disabled Students

For all students with impairments, just one librarian was appointed to administer and execute the library services (Mutanga, 2017). Most impaired students do not have access to adequate learning environments, teaching facilities, or classroom amenities; moreover, minimal attention is given to disabled students in the teaching and learning process as well as within higher education, and a lack of curricular flexibility and inclusive teaching and learning approaches is a significant hurdle (Kabuta, 2014). Patients are happy with examination and other assessment methods because they have adequate time to study for their exams, test items measure what they have learned, and test item scoring is fair (Malak et al., 2014). There is a need to entrench institutional disability policy and practices throughout higher education institutions. It is also important to understand how instructors from other disciplines perceive and experience disability (Hussain et al., 2020a).

When the admission test is organized, higher education creates impediments for disabled students because the admission test is administered formally with multiple-choice questions, limiting the number of candidates for whom, unless there are specific student instances that require special assistance, there is no previous consideration for accommodating pupils with special needs; furthermore, the results reveal that institutionalized inclusion is lacking due to the lack of institutionalized special services, offices that handle students' needs, personalized counseling services, and student orientation services (Zabeli et al., 2021). Some physically impaired students said that they were treated similarly in the classroom to nondisabled students and that study resources such as books,

handouts, brochures, and other academic materials were supplied equally to all students (Hauwadhanasuk et al., 2018).

H1: There is a negative impact of academic problems faced by disabled students on the learning environment needed to pursue higher education.

3.2.2. Infrastructural Settings and Complications Faced by Disabled Students

New buildings, according to students with disabilities who were questioned, are still troublesome since there is far too much gap between the seat sections, the platform, and the board (Mutanga, 2017). After analyzing the findings, it was discovered that 75% of the higher education institutions had infrastructure available but inadequate, which means that infrastructure is available but not adequate for disabled students and that most infrastructure conditions are average or poor. In terms of library facilities, disabled students are not easily accessible because the library's stairs are unfriendly, they fail to climb up, and some books are challenging to find (Kabuta, 2014). Institutions may also provide greater accessibility inside their grounds for students with disabilities, such as visual impairments, but may not have programs for students in wheelchairs (Saksena & Sharma, 2015).

According to the data, more than 70% of students with disabilities assessed classrooms, libraries, laboratories, and administrative offices as outstanding or exceptional in terms of accessibility to washrooms, and 36% of the students assessed them as ordinary or below average (Zabeli et al., 2021). This is a source of worry, and additional work should be done to enhance access to bathrooms in institutions. Classrooms, dormitories, ICT labs, language/science labs, dining halls, administrative offices, washrooms, and playgrounds were all inaccessible to physically disabled students at universities; these areas included classrooms, dormitories, ICT labs, language/science labs, dining halls, administrative offices, washrooms, and playgrounds (Kabuta, 2014).

H2: Infrastructural settings of higher educational institutions are not friendly for disabled students.

3.2.3. Financial Solvency and Complications Faced by Disabled Students

Financial difficulties are a major concern for disabled students, as most disabled students receive loans from nongovernmental organizations rather than from government assistance; however, the government is unaware of a full scholarship for disabled students, and some institutional financial assistance is provided but is insufficient (Kabuta, 2014). As a result, individuals grow reliant on their families for assistance. Household income is critical in terms of the ability to cover the undisclosed and forward expenditures of higher education (Akanle, 2007, as cited in Saksena & Sharma, 2015). Students from low-income homes have limited access to educational resources and opportunities to succeed in school; depriving pupils of their social and economic needs leads to low academic attainment (Madaus, Grigal, & Hughes, 2014). The financial assistance provided to

students with disabilities by the government or their parents was sufficient to cover direct schooling expenditures such as tuition, transportation, meals, lodging, and stationery. Approximately 66.7% of the help they received was enough to cover direct schooling costs, while 33.3% did not receive appropriate support to cover direct university fees (Kabuta, 2014).

HB: Most students with disabilities at higher education institutions face financial crises.

3.2.4. Social Obstacles and Complications Faced by Disabled Students

Although disabled students try to participate in social life, they face difficulties and challenges and are unable to directly participate in cultural and social activities; additionally, they are unable to participate in sports and games due to a variety of factors, including a lack of tools and playgrounds specifically designed for physically disabled students, despite having talents and interests comparable to those of normal students (Kabuta, 2014). They do not participate in sports or activities for a variety of reasons, including a lack of appropriate equipment and playgrounds for physically challenged pupils. This involves providing accessible playgrounds, as well as enough sports and game equipment, not only for regular students but also for students with physical impairments who have the same interests and talents in games as regular students (Hauwadhanasuk et al., 2018). Poor and inaccessible infrastructure, such as small walkways and stairs in university health clinics, was blamed by some students with physical limitations (Kabuta, 2014).

HA: Most disabled students at higher education institutions experience social obstacles.

3.2.5. Supportive Environment and Complications Faced by Disabled Students

Non-academic personnel must understand what works and what does not regarding creating accessible settings for students with disabilities. This is also true for higher education administrators and managers, whose voices are missing from most of the research evaluated (Mutanga, 2017). Institutional theory does this by providing higher education and disability policymakers with tools to assess the degree to which students' chances are encouraged or hampered inside and across higher education institutions; moreover, it is feasible to transcend academic attainment measurements based only on students' exam scores and graduation rates by focusing on their possibilities and quite well (Zhang et al., 2018). Some pupils managed with the help of a network of family, friends, and coaches, while others were self-taught. Crous (2004), as cited in Mutanga (2017), discovered that 67% of students with impairments considered their instructors to have little awareness of disability problems.

Most handicapped students stated that they receive sympathetic assistance from their fellow students and teachers; they occasionally feel pressured by members of the family who see them as a nuisance, but they receive complete help

from friends (Kabuta, 2014). Due to a lack of understanding of and sensitivity to disability concerns on the part of certain instructors, staff, and students, Student with Disabilities (SWD) experiences unfavorable attitudes and prejudices in the educational system, making it difficult for them to receive educational services equally (Saksena & Sharma, 2015).

H5: Students with disabilities at HEIs do not receive enough support from families, classmates, or faculty members.

After reviewing the above-discussed theoretical and conceptual framework, the following analytical framework was developed in this study (Figure 1).

4. Methodology of the Study

To understand the complications faced by disabled students in higher education institutions in Bangladesh, this study aimed to provide a comprehensive examination of the challenges encountered by this demographic group. Given the lack of extensive research on this topic within the Bangladeshi context, a quantitative field survey method was deemed appropriate to collect empirical data from a diverse sample of students. Therefore, quantitative surveys offer a standardized approach to data collection, reducing potential bias and subjectivity in responses. By employing closed-ended questions and structured formats, researchers can maintain consistency across respondents, enhancing the reliability of findings (Babbie, 2016). The inclusion criteria for the sample in this study encompassed students enrolled in various public universities and colleges across Bangladesh. This approach ensured the representation of a wide range of educational institutions, reflecting the diverse landscape of higher education in the country.

During the data collection phase, rigorous efforts were made to achieve a balanced representation of gender within the sample. The distribution of male and female participants, with 150 and 130 respondents respectively, aimed to capture potential gender-specific variations in the experiences of disabled students. Detailed sample distribution across different universities and colleges is provided in Table 1, under the sub-section 'Name of University/College.' This transparency in reporting enables readers to discern the geographic and institutional diversity of the sample, enhancing the study's credibility and generalizability.

The utilization of close-ended self-administered questionnaire surveys facilitated the systematic collection of data from participants. The questionnaire was carefully designed to encompass a broad spectrum of variables related to the challenges faced by disabled students, drawing upon insights from existing literature and the study of Rahman (2021). The decision to employ a convenient sampling approach, facilitated by the Kobo toolbox, was pragmatic in nature, allowing for efficient data collection across multiple educational settings within the specified timeframe. While convenient sampling may introduce limitations regarding sample representativeness, efforts were made to mitigate this through a diverse selection of institutions and participants. Quantitative analysis of the

collected data was conducted using SPSS software, enabling the exploration of patterns, trends, and associations within the dataset. Additionally, Confirmatory Factor Analysis (CFA) using AMOS software was employed to assess the structural validity of the measurement model, ensuring robustness in the interpretation of results.

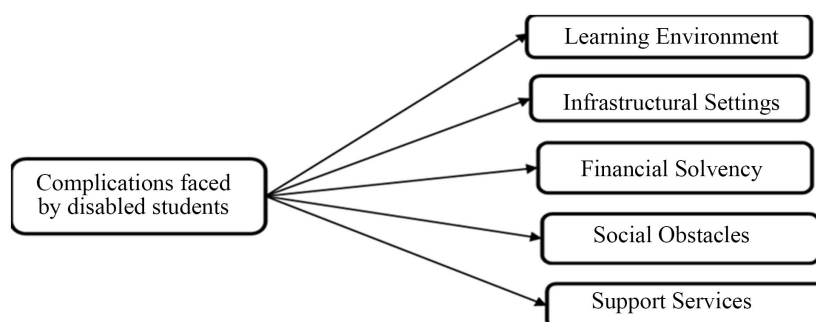

Figure 1. The analytical framework of the study.

Table 1. Socioeconomic profile of the sample respondents (n = 280).

Variables	Categories	Frequency	Cumulative distribution frequency	%
Gender	Male	150	150	53.6
	Female	130	280	46.4
Age	Below 20	26	26	9.3
	21 to 30	245	271	87.5
	31 to 40	6	277	2.1
	Above 40	3	280	1.1
Occupation	Student	250	250	89.3
	Teacher	19	269	6.8
	Others	11	280	3.9
Home Division	Barishal	10	10	3.6
	Chattogram	163	173	58.2
	Dhaka	37	210	13.2
	Mymensingh	16	226	5.7
	Khulna	14	240	5.0
	Rajshahi	15	255	5.4
	Rangpur	12	267	4.3
	Sylhet	13	280	4.6
Living Area	Rural	105	105	37.5
	Suburban	62	167	22.1
	Urban	113	280	40.4

Continued

	Comilla University	129	129	46.1
	Bangladesh University of Professional University of Chittagong	4	133	1.4
	University of Dhaka	19	152	6.8
	University of Rajshahi	20	180	7.1
	University of Rajshahi	8	188	2.9
	Shahjalal University of Sci. and Technology	5	193	1.8
	Bangabandu Sheikh Mojibur Rahman Maritime University	3	200	1.1
	Noakhali Science and Tech. University	5	208	1.8
	Bangladesh Open University	2	218	.7
	Government Titumir College	4	213	1.4
	Bangabandu Medical College	1	219	.4
	HM Danesh Sci. & Tech. University	4	223	1.4
Name of University/ College	Eden Mohila College	3	228	1.1
	Khulna University of Engineering & Tech.	3	231	1.1
	Dhaka College	2	233	.7
	Islamic University	6	239	2.1
	Jagannath University	9	248	3.2
	Mawlana Bhashani Sci. & Tech. University	3	251	1.1
	Barishal Medical College	1	252	.4
	Begum Rokeya University	3	255	1.1
	Government Bangla College	2	257	.7
	Jatiya Kabi Kazi Nazrul Islam University	3	264	1.1
	Bangabondu Sheikh Mujibur Rahman Sci. and Tech. University	2	266	.7
	Jahangirnagar University	4	270	1.4
	Bangladesh Agricultural University	3	278	1.1
	University of Barishal	2	280	.7
	Science	64	64	22.9
	Arts and Humanities	53	117	18.9
Major Discipline (Faculty)	Social Science	69	186	24.6
	Business Studies	40	226	14.3
	Engineering	26	252	9.3
	Law	21	273	7.5
	Others	7	280	2.5
	Bachelors	236	236	84.3
Degree of Education	Masters	36	272	12.9
	Others	8	280	2.9

Continued

Father's Occupation	Public Employee	36	36	12.9
	Private Employee	26	62	9.3
	Farmer	23	85	8.2
	Unemployed	10	95	3.6
	House-husband	3	98	1.1
	Others	60	158	21.4
Mother's Occupation	Public Employee	6	6	2.1
	Private Employee	5	11	1.8
	Farmer	4	15	1.4
	Unemployed	4	19	1.4
	Housewife	130	149	46.4
	Others	9	158	3.2
Family Income (Monthly)	Below 20,000	68	68	24.3
	20,000 to 30,000	41	109	14.6
	30,000 to 50,000	37	146	13.2
	More than 50,000	12	158	4.3

5. Results and Discussion

5.1. Socioeconomic Profile of the Sample Respondents

This section provides demographic information about the students (respondents) from different public, private and national universities in Bangladesh. The given table shows the results of the questions in terms of sex, age, occupation, home division, living area, name of the faculty, education, and family income (monthly). All the information is presented as primary data.

Table 1 shows the socioeconomic and basic information of the respondents, which was categorized based on age, sex, home division, living area, occupation of respondents and their parents, name of their university, major discipline, stages of education, and family income (monthly). **Table 1** shows that most of the total respondents were male (53.6%), whereas the remaining respondents were female (46.4%), which indicates that the percentage of male students in higher education is greater than that of their female counterparts. Conversely, most of the respondents in the study were aged between 21 and 30 years, which is 87.5%. Based on occupation, the respondents were divided into three sections, where 89.3 percent of the respondents were students, which was the highest sample of respondents.

To reduce uniformity, 58.2% of the respondents were selected from various divisions of the country where the highest number of respondents participated according to the Chattogram. Among all the respondents, most were from urban areas (40.4%), followed by rural (37.5%) and suburban (22.1%) areas of Bangladesh. Furthermore, the sample respondents are classified according to their de-

gree of education, where the greatest number of respondents is “masters”, which is 84.3%. Nearly a quarter of the sample respondents (24.6%) had a social science background regarding the “main discipline” question. The second-highest percentage comes from the science discipline (22.9%), followed by the art and humanities, business studies, engineering and technology, and law.

Several public universities and colleges in Bangladesh, including Comilla University, University of Dhaka, University of Chittagong, University of Rajshahi, were included in the study. All the sample respondents for this study were students enrolled in these institutions. Overall, the percentage of students who were from Comilla University was greater than that of any other university in the table; this figure was approximately 46% because of the close attachment of the researchers to this university. Seven percent of the students belonged to the University of Dhaka, which was the second highest, followed by the University of Chittagong (6.8%), Jagannath University (3.2%), the University of Rajshahi (2.9%), and Islamic University (2.1%), and the remaining 21.2% of the students were studying at other selected institutions.

5.2. Validity and Reliability Results

According to **Table 2**, the composite reliability (CR) of each latent construct is greater than the acceptable value of 0.70, where $CR = (\sum\lambda)^2 / [(\sum\lambda)^2 + \sum(1 - \lambda^2)]$ in terms of validity and reliability. This demonstrated that there was strong internal consistency in the scale items. Conversely, the average variance extracted (AVE) for each latent construct surpasses the threshold limit of 0.5, where $AVE = \sum\lambda^2 / n$. This finding confirms that the above-discussed CFA measurement model has strong convergent validity.

Measuring reliability is difficult, however, as it involves examining the measuring scale’s characteristics and its internal consistency (Hair et al., 2006). To assess reliability, this study used Cronbach’s alpha, a metric that is frequently used with Likert scale survey questions. Cronbach’s alpha values for each of the structures taken individually are provided in **Table 3**. The researchers used SPSS Output to compile the data that is being provided here. A Cronbach’s alpha reliability between ± 0.41 and ± 0.70 indicates moderate scale reliability, whereas a value greater than ± 0.70 indicates excellent internal consistency (Sekaran & Bougie, 2019). Cronbach’s alpha values higher than 0.70 to 0.90 are considered unacceptable (Taber, 2018). As shown in **Table 3**, all the latent constructs (e.g., learning environment, infrastructure settings, financial solvency, social obstacles, and support from family, classmates, and faculty members) had Cronbach’s alpha values greater than .80, indicating internal consistency and allowing further analysis.

5.3. Independent Sample t-Test

An independent sample t test was used to compare mean scores between two different groups of individuals or between cases in a between participant design

(for example, male vs female; experimental vs control group) (Sedgwick, 2010). An independent sample t test was conducted to compare the 5 hypotheses for sample respondents following the $t(df) = t$ value, $p = p$ value formula, and the results (see Table 4) are shown.

Table 2. Validity and reliability results.

Latent Constructs	Λ	λ^2	$1 - \lambda^2$	CR	AVE
Learning Environment (LE)	0.529	0.279841	0.720159	0.886	0.593
	0.585	0.342225	0.657775		
	0.635	0.403225	0.596775		
	0.626	0.391876	0.608124		
Infrastructural Settings (IS)	0.725	0.525625	0.474375	0.947	0.731
	0.728	0.529984	0.470016		
	0.743	0.552049	0.447951		
	0.73	0.5329	0.4671		
Financial Solvency (FS)	0.678	0.459684	0.540316	0.918	0.617
	0.679	0.461041	0.538959		
	0.611	0.373321	0.626679		
	0.503	0.253009	0.746991		
Social Obstacles (SO)	0.686	0.470596	0.529404	0.955	0.670
	0.652	0.425104	0.574896		
	0.698	0.487204	0.512796		
	0.705	0.497025	0.502975		
	0.613	0.375769	0.624231		
Support from Family, Classmates, and Faculty Members (SFCF)	0.619	0.383161	0.616839	0.856	0.640
	0.646	0.417316	0.582684		
	0.657	0.431649	0.568351		

Table 3. Reliability of the constructs.

Latent Constructs	Cronbach's Alpha	No. of Items
Learning Environment (LE)	0.851	4
Infrastructural Settings (IS)	0.906	4
Financial Solvency (FS)	0.806	4
Social Obstacles (SO)	0.872	5
Support from Family, Classmates, & Faculty Members (SFCF)	0.836	3

Table 4. Independent sample T test.

Hypothesis	N	Mean	SD	Levene's Test for Equality of Variances			t test for Equality of Means			
				F	Sig.	T	Df	Sig. (2-tailed)	95% Confidence Interval of the Difference	
									Lower	Upper
H ₁	19	1.61	0.60440	13.292	0.000	-3.815	21.246	0.001	-0.85220	-0.25121
	71	2.16	0.34563							
H ₂	21	1.53	0.46730	5.811	0.018	-6.065	25.253	0.000	-0.87899	-0.43350
	77	2.18	0.31765							
H ₃	15	1.38	0.43653	2.182	0.144	-6.276	16.817	0.000	-0.99023	-0.49165
	65	2.12	0.28320							
H ₄	14	1.46	0.44098	3.950	0.050	-6.228	15.866	0.000	-1.03477	-0.50892
	71	2.19	0.32318							
H ₅	14	1.27	0.31932	0.074	0.787	-9.100	18.354	0.000	-1.04367	-0.65258
	64	2.11	0.29975							

An independent sample t test was conducted to compare the learning environment (LE) for sample respondents under hypothesis 1. The results showed that there was a negative impact of academic problems faced by disabled students pursuing higher education, as these students had lower willingness scores ($M = 1.6068$, $SD = 0.60440$) than did those who did not ($M = 2.1585$, $SD = 0.34563$). There were significant differences ($t(21.246) = -3.815$, $p = 0.001$, $p < 0.05$). The magnitude of the differences in the means (mean difference = -0.55170 , 95% CI: -0.85220 to -0.25121) was significant. Together, these findings suggest that there is a negative impact of academic problems faced by disabled students pursuing higher education, which supports hypothesis 1. For hypothesis 2, the results showed that the infrastructural settings of HEIs are not friendly for disabled people, who have lower willingness scores ($M = 1.5263$, $SD = 0.46730$) than do those who do not ($M = 2.1826$, $SD = 0.31765$). There were significant differences ($t(25.253) = -6.065$, $p = 0.000$, $p < 0.05$). The magnitude of the differences in the means (mean difference = -0.65625 , 95% CI: -0.87899 to -0.43350) was also significant. Together, these findings suggest that the infrastructural settings of HEIs are not friendly for disabled people, which ultimately supports hypothesis 2.

Accordingly, an independent sample t test was conducted to compare the financial solvency (FS) of the sample respondents under hypothesis 3. The results showed that most of the students with disabilities at HEIs faced financial crises had lower willingness scores ($M = 1.3771$, $SD = 0.43653$) than did those who did not ($M = 2.1181$, $SD = 0.28320$). There were significant differences ($t(16.817) = -6.276$, $p = 0.000$, $p < 0.05$). The magnitude of the differences in the means (mean difference = -0.74094 , 95% CI: -0.99023 to -0.49165) was also significant. Together, these findings suggest that most of the students with disabilities at HEIs faced financial crises, supporting hypothesis 3. Hence, an independent

sample t test was conducted to compare social obstacles (SOs) for the sample respondents under hypothesis 4. The results showed that most of the disabled students at HEIs experienced social obstacles and had lower willingness scores ($M = 1.4155$, $SD = 0.44098$) than did those who did not ($M = 2.1873$, $SD = 0.32318$). There were significant differences ($t(15.866) = -6.228$, $p = 0.000$, $p < 0.05$). The magnitude of the differences in the means (mean difference = -0.77185 , 95% CI: -1.03477 to -0.50892) was significant. Taken together, these findings suggest that most disabled students at HEIs have experienced social obstacles, which supports hypothesis 4. According to hypothesis 5, students with disabilities at HEIs do not receive enough support from families, classmates, or faculty members; these students have lower willingness scores ($M = 1.2650$, $SD = 0.31932$) than do those without disabilities ($M = 2.1131$, $SD = 0.29975$). There were significant differences ($t(18.354) = -9.100$, $p = 0.000$, $p < 0.05$). The magnitude of the differences in the means (mean difference = -0.84813 , 95% CI: -1.04367 to -0.65258) was also significant. Taken together, these findings suggest that students with disabilities at HEIs do not receive enough support from families, classmates, or faculty members, which also supports hypothesis 5.

5.4. Confirmatory Factor Analysis (CFA)

CFA was employed to determine whether each measured variable correctly reflected its corresponding latent component. The latent construct “Nondisabled Students’ Observations of Complications Faced by Disabled Students” includes several subconstructs with their associated measured variables to investigate nondisabled students’ observations of complications experienced by handicapped students. The CFA measurement model (Figure 2), generated by the researchers using AMOS software for the same latent construct, and is illustrated here.

The Table shows how each measured variable is related to its corresponding theoretical construct. The major latent variable, “Nondisabled Students’ Observations of Complications Faced by Disabled Students,” is depicted in Figure 2 as measured by its five subconstructs: “Learning Environment (LE), Infrastructural Settings (IS), Financial Solvency (FS), Social Obstacles (SO), and Support from Family, Classmates and Faculty Members (SFCF).

The learning environment (LE), the first subconstruct, coded as “L,” is measured using four statements (LE1, LE2, LE3, and LE4) that are represented by rectangles in accordance with the standard used for observable variables. The second subconstruct, “Infrastructural Settings (IS),” coded as “I,” is measured using four assertions (IS1, IS2, IS3, and IS4). The same is true for the “financial solvency (FS)” variable, which is coded as “F” and is determined by four statements (FS1, FS2, FS3, and FS4). The fourth subconstruct, ‘Social Obstacles (SO),’ denoted by the letter “S,” is measured by three assertions denoted by the letters (SO1, SO2, SO3, and SO4). Finally, the fifth and final subconstruct, “Support from Family, Classmates, and Faculty Members’ (SFCF), is coded with ‘SF’ and measured by three statements (SFCF1, SFCF2, and SFCF3).

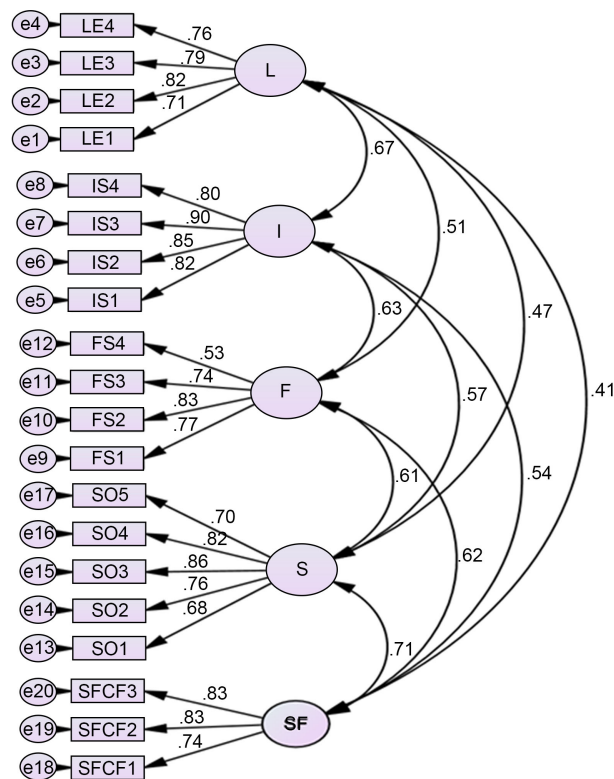

Figure 2. CFA Measurement model.

However, residual terms, which illustrate how much of the endogenous variable’s variance the exogenous variable is unable to explain, are shown by the small circles with arrows. The vicinity of the drawn pointing arrow indicates the factor loading for a specific item, and many correlations are noted above each response item of a manifest variable.

5.5. Model Fit

Table 5 shows the CMIN/DF value, which is 2.536 and less than the threshold of 3. These findings demonstrated that the data and model fit were consistent. The model resulted in various fit indices, including CFI = 0.926, NFI = 0.884, and TLI = 0.912, all of which are above their respective threshold bounds. These numbers show how well the model fits. The data also correctly fit the model, as indicated by the two badness indices, RMSEA = 0.074 (below 0.10). A lower RMSEA indicates a better fit. Therefore, it is evident that the CFA measurement approach is accurate.

5.6. Facilities for Disabled Students at HEIs in Bangladesh

The purpose of this portion of the study is to assess the facilities of higher education in Bangladesh for students with disabilities. In this regard, approximately 65.7% and 72.1% of respondents, respectively, stated that there are no classrooms or dormitories in their respective institutions that are accessible to students with disabilities. Concerning classroom and dormitory conditions, around

41.7% and 40.3% of respondents, respectively, stated that classroom and dormitory conditions for disabled students in their institutions are average, while about 18% and 26% respondents opined that classroom and dormitory conditions are poor and very poor respectively (**Table 6**).

Table 5. CFA model-fit summary.

Model Fit Indices	Threshold Limits	Values Attained
RMSEA	<0.05 good fit; 0.05 - 0.10 mediocre fit, and if >0.10 bad fit	0.074
CFI	>0.95 great; >0.90 traditional; and if >0.80 sometimes permissible	0.926
TLI	>0.90	0.912
NFI	>0.90	0.884
CMIN/DF	<3 good; and if <5 sometimes permissible	2.536

Table 6. Facilities for disabled students at HEIs in Bangladesh.

Variables	Categories	Frequency distribution	Cumulative frequency	%
Disabled friendly classrooms in institution	Yes	95	95	33.9
	No	184	279	65.7
The conditions of the classrooms	Very good	8	8	8.3
	Good	31	38	32.3
	Average	40	78	41.7
	Poor	10	88	10.4
	Very poor	7	95	7.3
Disabled friendly dormitories	Yes	78	78	27.9
	No	202	280	72.1
The conditions of the dormitories	Very good	5	5	6.5
	Good	21	26	27.3
	Average	31	57	40.3
	Poor	13	70	16.9
	Very poor	7	77	9.1
Disabled friendly dining halls	Yes	81	81	28.9
	No	199	280	71.1
The conditions of the dining halls	Very good	4	4	5.0
	Good	17	21	21.3
	Average	32	53	40.0
	Poor	19	72	23.8
	Very poor	8	80	10.0
Disabled friendly administrative offices	Yes	69	69	24.6
	No	211	280	75.4

Continued

The conditions of the administrative offices	Very good	8	8	11.6
	Good	22	30	31.9
	Average	27	57	39.1
	Poor	10	67	14.5
	Very poor	2	69	2.9
Disabled friendly playgrounds	Yes	72	72	25.7
	No	208	280	74.3
The conditions of the playgrounds	Very good	8	8	11.0
	Good	17	25	23.3
	Average	36	61	49.3
	Poor	10	71	13.7
	Very poor	2	72	2.7
Disabled friendly washroom	Yes	82	82	29.3
	No	197	279	70.4
The conditions of the washroom	Very good	8	8	9.3
	Good	19	27	22.1
	Average	31	58	36.0
	Poor	16	74	18.6
	Very poor	12	86	14.0

Moreover, about 71.1% and 75.4% of respondents respectively mentioned that halls and administrative offices at their respective institutions are not disabled friendly. Concededly, about 74.3% and 70.4% of the respondents separately narrated that playgrounds and washrooms both are incompatible for the students with disabilities. Considering all the selected criteria, facilities at HEIs in Bangladesh for disabled students are not in good condition. In most cases, they are faced with poor facilities.

5.7. Complications Faced by Disabled Students at HEIs

Table 7 presents a list of barriers and challenges faced by students with physical disabilities in the learning environment. The table is organized into five categories, including Learning Environment (LE), Infrastructural Settings (IS), Financial Solvency (FS), Social Obstacles (SO), and Support from Families, Classmates, and Faculty Members (SFCF).

For each category, several specific barriers are listed along with their associated scores based on a rating system. The rating system included two sub-categories, Strongly Disagree (SD) and Disagree (D), which were used to calculate the total score (1 + 2) for each barrier. Additionally, the table provides information on the total number of neutral (N) respondents who participated in the survey, the Agree (A) rating for each barrier, the Strongly Agree of A (SA), and the Total

Table 7. Complications faced by disabled students at HEIs in Bangladesh.

Code	Variables	SD (1)	D (2)	Total (1 + 2)	N (3)	A (4)	SA (5)	Total (4 + 5)
Learning Environment (LE)								
LE1	Teaching and learning materials are not available for students with physical disabilities	1.4	11.8	13.2	21.8	46.1	18.9	65
LE2	Teaching and learning materials are not accessible for students with physical disabilities	2.5	19.3	21.8	22.9	40.7	14.6	55.3
LE3	Teaching and learning methods used by teachers are not inclusive for students with physical disabilities	3.6	16.8	20.4	26.8	37.9	15	52.9
LE4	Libraries and LABs are not accessible to physically disabled students	3.9	23.2	27.1	23.9	32.9	16.1	49
Infrastructural Settings (IS)								
IS1	Library facilities and conditions are not adequate and available for disabled students	3.2	16.8	20	23.6	40.7	15.7	56.4
IS2	LAB facilities and conditions are not adequate and available for disabled students	3.2	16.1	19.3	23.2	44.3	13.2	57.5
IS3	ICT facilities and equipment are not available and accessible for disabled students	3.6	16.4	20	25.7	38.9	15.4	54.3
IS4	Disable friendly classrooms, dormitories, dining halls, administrative offices, playgrounds, and washrooms are not available and accessible	2.9	15.4	18.3	23.2	43.6	15	58.6
Financial Solvency (FS)								
FS1	Governmental financial support (Scholarship/Stipends) is not sufficient for disabled students	2.9	9.3	12.2	27.1	44.6	16.1	60.7
FS2	Subsidy given from your institute for students with disabilities is not satisfactory	2.1	9.6	11.7	28.9	45.4	13.9	59.3
FS3	Family's financial support is not satisfactory for disabled students	1.8	10.4	12.2	33.6	42.1	12.1	54.2
FS4	Financial support from NGOs is limited and poor for disabled students	7	10	17	29.3	43.9	16.1	60
Social Obstacles (SO)								
SO1	Students with disabilities at your institution experience difficulties in participating and interacting with other students	2.9	8.6	11.5	26.4	45	17.1	62.1
SO2	Students with disabilities at your institution face difficulties to get accessibility for health services	2.1	12.5	14.6	29.3	40.7	15.4	56.1

Continued

SO3	Students with disabilities at your institution face obstacle to participating in cultural and social activities	3.2	11.8	15	30	38.9	16.1	55
SO4	The participation or freedom of worship is not favourable for disabled students	4.3	11.8	16.1	30	37.9	16.1	54
SO5	The participation in sports is not accessible and available for students with physical disabilities	1.8	13.6	15.4	25.7	43.6	15.4	59
Support from Family, Classmates and Faculty Members (SFCF)								
SFCF1	Students with disabilities at your institution do not get enough support from families	3.6	18.2	21.8	28.6	36.1	13.6	49.7
SFCF2	Students with disabilities at your institution do not get enough support from fellow classmates	4.3	22.1	26.4	30.4	32.1	11.1	43.2
SFCF3	Governmental support is not sufficient for disabled students	2.5	20.4	22.9	35.4	32.9	8.9	41.8

score for A and SA (4 + 5). Concerning learning environment (LE), about 65% and 55.3% of respondents respectively mentioned that they did not have access and available teaching and learning materials, while 13.2% and 21.8% respectively said they have and the rests of them were neutral (21.8% and 22.9% respectively). Additionally, respectively 52.9% and 49% of respondents did not have inclusive teaching and learning methods used by teachers, as well as libraries and LABs are not accessible for students with physical disabilities. Regarding infrastructural settings (IS), about 56.4% and 57.5% of respondents respectively mentioned that they did not have library and LAB facilities, whereas 20% and 19.3% respectively stated that they have, and respectively 23.6% and 23.2% respondents were neutral. Furthermore, about 54.3% of respondents found ICT facilities and equipment unavailable. Moreover, disable friendly classrooms, dormitories, dining halls, administrative offices, playgrounds, and washrooms are not available and accessible mentioned by 58.6% of respondents. As for scholarship opportunities and subsidy given by the institution as financial solvency (FS), more students are found to be dissatisfied (60.7% and 59.3% of respondents respectively) than those who are satisfied (12.2% and 11.7% respectively). Moreover, 54.2% and 60% of respondents were dissatisfied with the financial support of family and NGOs respectively. In terms of social obstacles (SO), 62.1% and 55% of respondents experienced difficulties in participating and interacting with other students as well as cultural and social activities respectively. About 56.1% of respondents faced difficulties to get health accessibility, whereas 54% and 59% of respondents found unfavorable conditions in participating worship and sports respectively. Concerning all the aspects of the selected variables in this study, most of the respondents found that disabled students lacked all the facilities

needed.

6. Conclusion and Recommendations

Overall, the results make it very clear that there are many barriers to schooling for students with physical limitations. These barriers include the absence of accessible learning environments, poor infrastructure, budget constraints, social challenges, and lack of adequate family, peer, and instructor support. Moreover, braille books for the visually impaired from high school to university are few and far between, and it becomes difficult for them to seek help from others for dictation. There are no sign language interpreters for hearing impairments outside of special education institutions, and most educational institutions are not accessible to people physically challenged. For higher education, these students must enroll in mainstream universities, most of which do not have adequate teaching materials. Consequently, universities are not disabled friendly. Addressing these issues comprehensively and systematically, enlisting diverse stakeholders, and implementing evidence-based policies and procedures are essential. This will greatly increase educational opportunities for people with physical limitations. Moreover, the government should take special initiative to accept disabled students' rights at HEIs concerning all the facilities that disabled students enjoy.

Although the government has formulated some policies from time to time to help students with disabilities, universities in Bangladesh have made little progress due to lack of will, and weak coordination among the responsible agencies. Additionally, research shows that framework policies to provide support for students with disabilities are not superficial rhetoric but real intent and full implementation (Hussain et al., 2020b). Therefore, teaching and learning methods should be updated and modified according to the special needs of persons with disabilities. In addition, academic institutions should adapt existing buildings to make them suitable for people with disabilities, while new buildings should be designed to be more user-friendly for people with special needs (Hussain et al., 2020b). Civil society organizations can also play an effective role through advocacy and awareness-raising to provide equal educational opportunities for all disable students with nondisabled mates. To sustainably address the issue of opportunities for students with disabilities, the University Grants Commission (UGC) of Bangladesh should ensure that the needs of students with disabilities are given priority while planning and developing the university.

Therefore, the findings of this study are aligned to the Social Model of disability, which posits that disabled individuals are not inherently limited by their impairments, but rather by societal attitudes, inaccessible environments, and discriminatory practices. In this regard, the Social Model underscores the necessity of structural and systemic changes to address these barriers effectively, which involves implementing inclusive policies, offering reasonable accommodations, and promoting universal design principles to ensure that educational environments are accessible to all students, irrespective of their abilities (Shakespeare, 2006; Barnes, 2012).

Acknowledgements

The authors are very grateful to the respondents of this study who assisted voluntarily to provide valuable information for creating a concrete result.

Disclosure Statement

This is to acknowledge that there are no competing interests to declare. There is also no financial or non-financial interest among the authors in this study.

Conflicts of Interest

The authors declare no conflicts of interest regarding the publication of this paper.

References

- Ahsan, M. T., & Burnip, L. (2007). Inclusive Education in Bangladesh. *Australasian Journal of Special Education*, 31, 61-71. <https://doi.org/10.1017/S1030011200025598>
- Akhter, F., & Rahman, M. A. (2017). Financial Constraints and Access to Higher Education: Perspectives of Disabled Students in Bangladesh. *International Journal of Disability, Development, and Education*, 64, 520-535.
- Ayub, S. (2021). *Obstacles Faced by Students with Disabilities in Colleges Due to the Lack of Inclusive Educational Frameworks in Pakistan*. Unpublished Master Thesis, College of Education, Psychology and Social Work, Flinders University.
- Babbie, E. R. (2016). *The Practice of Social Research*. Cengage Learning.
- Barnes, C. (2012). *Understanding Disability: From Theory to Practice*. Macmillan International Higher Education.
- Bualar, T. (2018). Barriers to Inclusive Higher Education in Thailand: Voices of Blind Students. *Asia Pacific Education Review*, 19, 469-477. <https://doi.org/10.1007/s12564-017-9512-7>
- Büscher-Touwen, M., Groot, M., & Hal, L. (2018). Mind the Gap between Higher Education and the Labour Market for Students with a Disability in the Netherlands: A Research Agenda. *Social Inclusion*, 6, 149-157. <https://doi.org/10.17645/si.v6i4.1655>
- Davis, F. D., Bagozzi, R. P., & Warshaw, P. R. (1992). The Role of Social Support in Technology Adoption: A Meta-Analysis of the Empirical Evidence. *Journal of Systems Management*, 42, 123-139.
- Dorji, R., Bailey, J., Paterson, D., Graham, L., & Miller, J. (2021). Bhutanese Teachers' Attitudes towards Inclusive Education. *International Journal of Inclusive Education*, 25, 545-564. <https://doi.org/10.1080/13603116.2018.1563645>
- Dulal (2003). Expert Group Meeting and Seminar on an International Convention to Protect and Promote the Rights and Dignity of Persons with Disabilities. *Bangkok, Thailand, Country Paper: Bangladesh*.
- Engelbrecht, L., & De Beer, J. J. (2014). Access Constraints Experienced by Physically Disabled Students at a South African Higher Education Institution. *Africa Education Review*, 11, 544-562. <https://doi.org/10.1080/18146627.2014.935003>
- Fuller, M., Bradley, A., Hall, T. R., & Healey, M. J. (2006). Listening to Students: The Experiences of Disabled Students of Learning at University. In T. Wall, J. Turner, & M. E. Meyer (Eds.), *towards Inclusive Learning in Higher Education* (pp. 33-43). Routledge.
- Fuller, M., Healey, M., Bradley, A., & Hall, T. (2004). Barriers to Learning: A Systematic

- Study of the Experience of Disabled Students in One University. *Studies in Higher Education*, 29, 303-318. <https://doi.org/10.1080/03075070410001682592>
- Gill, K., Sharma, R., Gupta, R., Professor, A., & Professor, A. (2017). Empowering Visually Impaired Students through E-Learning at Higher Education: Problems and Solutions. *IOSR Journal of Humanities and Social Science (IOSR-JHSS)*, 22, 27-35.
- Gilson, C. L., & Dymond, S. K. (2010). Barriers Impacting Students with Disabilities at a Hong Kong University. *Journal of Postsecondary Education and Disability*, 25, 103-118.
- Haider, M. S. (2021). *Digital Technology and Disabled Students' Experience of Higher Education in Bangladesh*. Published Doctoral Thesis, Faculty of Education, Monash University.
- Hair, J. F., Black, W. C., Babin, B. J., & Anderson, R. E. (2006). *Multivariate Data Analysis* (6th ed.). Pearson Prentice Hall.
- Hauwadhanasuk, T., Karnas, M., & Zhuang, M. (2018). Inclusive Education Plans and Practices in China, Thailand, and Turkey. *Educational Planning*, 25, 29-48.
- Hosain, G. M., Atkinson, D., & Underwood, P. (2002). Impact of Disability on Quality of Life of Rural Disabled People in Bangladesh. *Journal of Health Population and Nutrition*, 20, 297-305.
- Hossain, R., & Islam, S. (2022). Promoting Inclusive Policies and Practices for Disabled Students in Higher Education: Lessons from Bangladesh. *Journal of Inclusive Education Policy*, 9, 34-49.
- Hussain, I., Hussain, A. et al. (2020a). Health Problems Faced by Disabled Children and Their Effect on Education: Disabled Students in the University Campus. *Journal of Emerging Technologies and Innovative Research (JETIR)*, 7, 708-711.
- Hussain, S., Shahzadi, U., & Khan, I. (2020b). Challenges to Learners with Disabilities in the Higher Education Institutions in Pakistan: A Review. *Research Journal of Social Sciences and Economics Review*, 1, 12-19. [https://doi.org/10.36902/rjsser-vol1-iss3-2020\(12-19\)](https://doi.org/10.36902/rjsser-vol1-iss3-2020(12-19))
- Hussein, H. (2012). The Influence of Sensory Gardens on the Behaviour of Children with Special Educational Needs. *Procedia-Social and Behavioral Sciences*, 38, 343-354. <https://doi.org/10.1016/j.sbspro.2012.03.356>
- Islam, F., & Ali, A. (2018). Policy and Legal Framework for Disability Rights in Higher Education: A Case Study of Bangladesh. *International Journal of Disability Studies in Education*, 3, 112-127.
- Jameel, S. S. (2011). Disability in the Context of Higher Education: Issues and Concerns in India. *Electronic Journal of Inclusive Education*, 2, 1-21.
- Kabuta, L. G. (2014). *Problems Facing Students with Physical Disabilities in Higher Learning Institutions in Tanzania*. Published Master's Thesis, The Open University of Tanzania.
- Khan, A., & Siddique, N. (2021). Support Services and Accommodations for Disabled Students in Higher Education: A Case Study of Selected Universities in Bangladesh. *Journal of Inclusive Education and Special Needs*, 8, 155-170.
- Kibria, G. (2005). Inclusion Education and the Developing Countries: The Case of Bangladesh. *Journal of the International Association of Special Education*, 6, 43-47.
- Lamichhane, K. (2017). Teaching Students with Visual Impairments in an Inclusive Educational Setting: A Case from Nepal. *International Journal of Inclusive Education*, 21, 1-13. <https://doi.org/10.1080/13603116.2016.1184323>
- Madaus, J. W., Grigal, M., & Hughes, C. (2014). Promoting Access to Postsecondary Education for Low-Income Students with Disabilities. *Career Development and Transi-*

- tion for Exceptional Individuals*, 37, 50-59.
<https://doi.org/10.1177/2165143414525037>
- Malak, M. S., Begum, H. A., Habib, M. A., Banu, M. S., & Roshid, M. M. (2014). Inclusive Education in Bangladesh: Are the Guiding Principles Aligned with Successful Practices? In H. Zhang, P. W. K. Chan, & C. Boyle (Eds.), *Equality in Education: Fairness and Inclusion* (pp. 107-124). SensePublishers. https://doi.org/10.1007/978-94-6209-692-9_9
- Marginson, S. (2016). The Worldwide Trend to High Participation Higher Education: Dynamics of Social Stratification in Inclusive Systems. *Higher Education*, 72, 413-434. <https://doi.org/10.1007/s10734-016-0016-x>
- Matshedisho, K. R. (2010). Experiences of Disabled Students in South Africa: Extending the Thinking behind Disability Support. *South African Journal of Higher Education*, 24, 730-744.
- Mitra, S. (2006). The Capability Approach and Disability. *Journal of Disability Policy Studies*, 16, 236-247. <https://doi.org/10.1177/10442073060160040501>
- Monem, M., & Baniamin, H. M. (2010). Higher Education in Bangladesh: Status, Issues, and Prospects. *Pakistan Journal of Social Sciences*, 30, 293-305. <https://pjss.bzu.edu.pk/index.php/pjss/article/view/76>
- Morley, L., & Croft, A. (2011). Agency and Advocacy: Disabled Students in Higher Education in Ghana and Tanzania. *Research in Comparative and International Education*, 6, 383-399. <https://doi.org/10.2304/rcie.2011.6.4.383>
- Mutanga, O. (2017). Students with Disabilities' Experience in South African Higher Education—A Synthesis of Literature. *South African Journal of Higher Education*, 31, 135-154. <https://doi.org/10.20853/31-1-1596>
- Nasir, S., & Hameed, M. (2021). Impact of COVID-19 on the Learning Processes of Typically Developing and Special Needs Students in Pakistan. *Asian Journal of University Education*, 17, 67-75. <https://doi.org/10.24191/ajue.v17i3.14526>
- Oliver, M. (1990). *The Politics of Disablement: A Sociological Approach*. St. Martin's Press. <https://doi.org/10.1007/978-1-349-20895-1>
- Rahman, A. (2021). Condition of Inclusivity in Public University of Bangladesh Specifically for the Disabled Student: A Case Study on Jahangirnagar University. *International Journal of Social Science and Human Research*, 4, 313-325. <https://doi.org/10.47191/ijsshr/v4-i3-12>
- Rahman, M. S., & Akhtar, R. (2020). Accessibility Challenges Faced by Disabled Students in Higher Education Institutions in Bangladesh. *Journal of Disability Management and Rehabilitation*, 5, 45-58.
- Saksena, S., & Sharma, R. (2015). Deconstructing Barriers to Access Higher Education: A Case Study of Students with Disabilities in University of Delhi. *DU Journal of Undergraduate Research and Inn*, 1, 316-337.
- Seale, J., Georgeson, J., Mamas, C., & Swain, J. (2015). Not the Right Kind of "Digital Capital"? An Examination of the Complex Relationship between Disabled Students, Their Technologies and Higher Education Institutions. *Computers and Education*, 82, 118-128. <https://doi.org/10.1016/j.compedu.2014.11.007>
- Sedgwick, P. (2010). Understanding the Difference between Confidence Intervals and Effect Sizes. *BMJ (Clinical Research ed.)*, 341, c4140.
- Sekaran, U., & Bougie, R. (2019). *Research Methods for Business: A Skill-Building Approach* (8th ed.). Wiley.
- Shakespeare, T. (2006). *Disability Rights and Wrongs*. Routledge. <https://doi.org/10.4324/9780203640098>

- Simui, F., Kasonde-Ngandu, S., Cheyeka, A. M., Simwinga, J., & Ndhlovu, D. (2017). Enablers and Disablers to Academic Success of Students with Visual Impairment: A 10-Year Literature Disclosure, 2007-2017. *British Journal of Visual Impairment*, *36*, 163-174. <https://doi.org/10.1177/0264619617739932>
- Simui, F., Muzata, K. K., Sakakombe, L., & Mtonga, T. (2020). Disablers to Academic Success of Learners with Special Education in Selected Higher Education Institutions in Zambia. *Zambian Journal of Educational Management, Administration and Leadership (ZJEMAL)*, *1*, 21-38. <https://vet.unza.zm/index.php/zjemal/article/view/212>
- Skivington, M. (2011). Disability and Adulthood in Mexico: An Ethnographic Case Study. *International Journal of Special Education*, *26*, 45-57.
- Strnadová, I., Hájková, V., & Květoňová, L. (2015). Voices of University Students with Disabilities: Inclusive Education on the Tertiary Level—A Reality or a Distant Dream? *International Journal of Inclusive Education*, *19*, 1080-1095. <https://doi.org/10.1080/13603116.2015.1037868>
- Taber, K. S. (2018). The Use of Cronbach's Alpha When Developing and Reporting Research Instruments in Science Education. *Research in Science Education*, *48*, 1273-1296. <https://doi.org/10.1007/s11165-016-9602-2>
- Taneja-Johansson, S. (2024). Facilitators and Barriers along Pathways to Higher Education in Sweden: A Disability Lens. *International Journal of Inclusive Education*, *28*, 311-325. <https://doi.org/10.1080/13603116.2021.1941320>
- The Business Standard (2023). *Majority of Children with Disabilities Are Not Enrolled in Any Formal Education: Survey*. The Business Standard. <https://www.tbsnews.net/bangladesh/majority-children-disabilities-are-not-enrolled-any-formal-education-survey-573142>
- Tugli, A. K. (2013). *Challenges and Needs of Learners with Disabilities in an Inclusive Institution of Higher Education in the Limpopo Province of South Africa*. Doctoral Dissertation, University of South Africa.
- UK Government (2019). *Review of Evidence on Disability Programmes in South Asia*. Amaltas Institute of Human Development, 3. <https://www.gov.uk/research-for-development-outputs/review-of-evidence-on-disability-programmes-in-south-asia-amaltas-consulting-new-delhi>
- Westwood, P. (2013). *Inclusive and Adaptive Teaching: Meeting the Challenge of Diversity in the Classroom* (1st ed.). Routledge. <https://doi.org/10.4324/9780203069806>
- Zabeli, N., Kačaniku, F., & Koliqi, D. (2021). Towards the Inclusion of Students with Special Needs in Higher Education: Challenges and Prospects in Kosovo. *Cogent Education*, *8*, Article 1859438. <https://doi.org/10.1080/2331186X.2020.1859438>
- Zhang, Y., Rosen, S., Cheng, L., & Li, J. (2018). Inclusive Higher Education for Students with Disabilities in China: What Do the University Teachers Think? *Higher Education Studies*, *8*, 104-115. <https://doi.org/10.5539/hes.v8n4p104>