

Field Test Summary of Two Kinds of Electronic Detonator for Seismic Exploration

Junguo Du, Biao Li, Zhaoxun Yang, Peng Ding, Shouxin Wu, Youcai He

BGP Southwest Geophysical Branch, CNPC, Chengdu, China

Email: dujg_wt@cnpc.com.cn

How to cite this paper: Du, J. G., Li, B., Yang, Z. X., Ding, P., Wu, S. X., & He, Y. C. (2023). Field Test Summary of Two Kinds of Electronic Detonator for Seismic Exploration. *Journal of Geoscience and Environment Protection*, 11, 315-326.

<https://doi.org/10.4236/gep.2023.113018>

Received: March 12, 2023

Accepted: March 28, 2023

Published: March 31, 2023

Abstract

Electronic detonators are widely used because of their advantages in real-time supervision of the whole life cycle (Zang, 2022). Due to the high requirements of the time difference synchronization between the electronic initiation system and the seismic wave recording system, the Electronic detonator has not been widely used for Seismic exploration (Yang, 2020). This paper expounds the systematic and scientific test method from the aspects of the comprehensive performance of electronic detonators for exploration, the compatibility between the electronic detonator initiation system and the geophysical blasting machine system, the constraints of the geophysical explosion-related collaborative Danling management cloud platform, and the quality of data collected by electronic detonator blasting in wells., and based on the analysis of the test results, the problems that need to be improved in the application of electronic detonators and detonation systems in the large-scale production of geophysical prospecting industry are put forward.

Keywords

Blast System, Seismic Exploration, Digital Electronic Detonator

1. Preface

Bureau of Geophysical Prospecting INC., China (BGP) carried out the research of two kinds of electronic detonators for exploration in April 2022, On-site system testing was carried out to study product stability and matching of practical results, and obtained reliable performance parameters of electronic detonators and composite initiation systems in seismic exploration, providing support for the promotion and application of electronic detonators.

2. Structure of Electronic Detonator for Exploration

Electronic control module placed inside the electronic detonator, with detonator

detonation delay time control, detonation energy control function, built-in detonator identity information code and detonation password (Jiang, 2021; Deng & Zhang, 2020). The digital electronic detonator is intrinsically safe, with high delay time accuracy and detonation accuracy, which is conducive to the accurate control of the whole life cycle (Figure 1 and Figure 2) (Hao, 2019; Cheng & Wang, 2020; Yang & Yue, 2021).

3. Principle of Composite Initiation System for Exploration

The seismic exploration excitation test work used a composite detonation system, the BoomBox remote detonation system (or shotproII) in the high-voltage output side of the electronic detonator detonation system, through a special circuit chip for the detonator, detonator UID number authentication, to ensure that the authorization of the civilian explosives network management platform to be able to detonate normally, with a certain time delay. The 2 types of detonators tested (Figure 3 and Figure 4), with slightly different structures (Table 1), are developed for seismic exploration construction with a special APP function module.

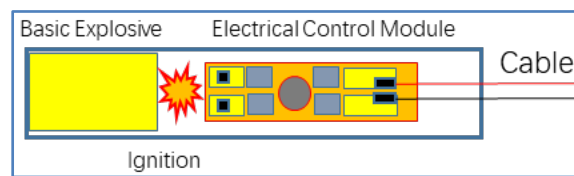

Figure 1. Schematic diagram.



Figure 2. Physical object of electronic detonator.



Figure 3. Connection diagram of type A electronic detonator initiation system.



Figure 4. Schematic diagram of connection of B-type electronic detonator initiation system.

Table 1. Combination detonation system of electronic detonator.

serial number	BoomBox and Detonator	Detonators and handsets	Detonators and electronic detonators
A	cable connection	NA	cable connection
B	cable connection	Wifi + Bluetooth connection	cable connection

4. Dan Lingyun Blasting Management Platform

Through the combination of the “Dan Lingyun” civil explosion information system and the electronic detonator initiation system APP, the life cycle flow monitoring of electronic detonators is realized. The whole process of digital management is implemented for the field use of electronic detonators. There are 6 main steps.

1) Log in the civil explosives information management platform of the public security agency, establish a blasting project, register the serial number of the detonator, set the blasting operation area (input the latitude and longitude coordinates), and complete the registration and filing of the detonator. Meanwhile Set up on the handheld, enter the construction unit and project name, operator account number and construction work scope, etc. Only authorized terminals can carry out corresponding blasting work.

2) Scan the QR code label of the electronic detonator with a handheld computer (or connect to the detonation network to read the identification code of the electronic chip), and enter and identify the serial number of the electronic detonator in batches.

3) Log in to the Danlingyun National Civil Explosions Information Management Platform, and apply for the activation code corresponding to the code of the electronic detonator within the specified period according to the authorization of the project contract (or apply for an extension of the validity period for the detonator that is about to expire).

4) Assemble the electronic detonator and shaped explosives and place them in the well, and then connect the detonation network. The detonation operation is carried out by using a special detonator and a matching password.

5) After the explosive explodes successfully, the handheld APP will generate a report file, including the code of the detonator, the excitation time, the responsi-

ble person, the location of the explosion point, etc., and upload it to the public security organ Danlingyun civil explosion information network service platform through the Internet. It has become an important file for the management of civil explosives in seismic exploration projects.

6) Through blasting license location and time control, registered blasting units, equipment and personnel authority management, electronic detonator use area distribution and actual usage report automation management, etc., the management of the whole process of using electronic detonators and other civilian explosives has been realized.

5. Electronic Detonator and Blast System Testing Application

5.1. Test Content

One Conventional electric detonators and two types of electronic detonators are used for testing, 4 items of testing is carried out, Include delay test, Capacity test, GDZ seismograph matching Test and seismic acquisition Testing (**Table 2**) (GB 8031, 2015; WJ 9085, 2015).

5.2. Electronic Detonator Delay Test

Two kind of test schedule used for detonator Blast delay test.

First, connect the detonator with BoomBox2 and ShotPro Blast instrument, the Sercel 428 XL recording system send out and receive the time Break signal. The encoder and decoder communicate through the Motorola GM338 radio.

Second, independent Blast system connect the detonators.

The 428 XL instrument is set to the highest sampling interval of 0.25 ms, the filter mode is set to 8 LIN, and the refraction delay time is set to 0 ms.

The equipment connection is shown in **Figure 5**.

The electronic detonator trigger signal input and BoomBox2 (or ShotPro) decoder high-voltage terminals connected to the output of the detonator and connected to the electronic detonator. A thin signal wire (copper wire) twisted and cut flush front end, with tape tightly wrapped around the bottom of the electronic detonator 3 - 5 mm position, the two ends and 10 meters long gun wire connected. One lead of the gun wire to access the positive terminal of the battery

Table 2. Testing application.

No.	Test content	Remark
1	Electronic Detonator Delay Test	Delay Must less than sample Rate 1 ms.
2	Electronic detonator carrying capacity test	5 - 15 - 30 parallel excitation
3	Matching test with GDZ (24B)seismograph	Leakage test in water
4	Multi-shot Continuous Excitation Construction Stability and Data Quality Test	Matching of shaped explosives to carry out point and line tests

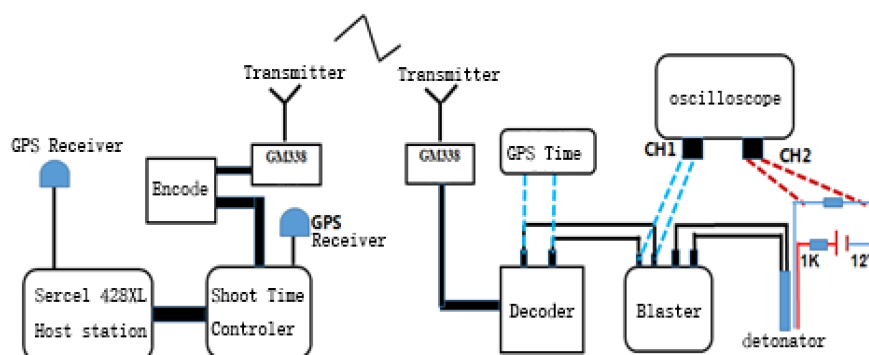

Figure 5. Schematic diagram of electronic detonator delay test.

with a voltage of about 12 V, the negative terminal of the battery and the other lead of the gun wire connected, the gun wire in series with two resistors, the two leads of one of the resistors to access the channel CH2 of the oscilloscope. channel CH1 of the oscilloscope to access the decoder high-voltage detonation signal, the channel CH2 is set to signal trigger record, that is, the signal line on the detonator ionization conductive jump signal trigger record (**Figure 6**).

This test uses BoomBox2, ShotPro explosive machine conventional mode, master-slave mode and autonomous excitation mode. The host of the 428 XL instrument issues ignition commands to complete the excitation of conventional electric detonators and type 2 electronic detonators respectively. One shot each time, 5 times each. Based on the wellhead detection record information, confirm the detonation delay of the single-shot electronic detonator. Test delay data acquisition: analyze the waveform diagram of the oscilloscope, and pick up the time difference of the jump signal when the signal line on the CH1 and CH2 channels is turned on (as shown in **Figure 7**).

Tests show that the conventional electric detonator releases from high voltage to detonation time within 72 - 121 μs ; the electronic detonator releases from high voltage to detonation time within 167 - 255 μs , which is slightly longer than conventional electric detonators, but The delay time is less than the data sampling rate of seismic exploration, which meets the seismic acquisition requirements (SY-T 6734, 2014).

5.3. Electronic Detonator Excitation Capacity Test

Multiple detonator connect together and shooting by Boombox Blaster at the same time, Blasting test order for 15 and 30 detonators, and one geophone is buried nearby and the seismic data just improve the excitation.

Test conclusion:

- 1) On-site inspection and wellhead record track information show that all electronic detonators are excitation (**Figure 8** and **Figure 9**).
- 2) The loading capacity of the electronic detonator excitation system reaches 30 pieces, which meets the construction requirements of complex seismic exploration.

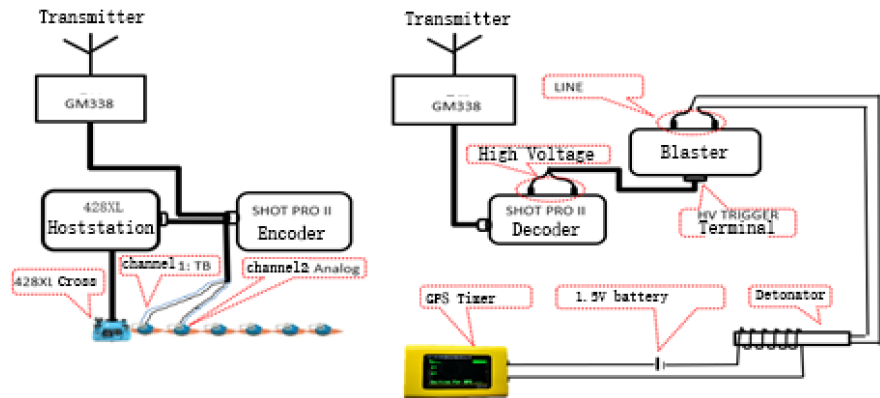

Figure 6. Shotpro Blaster and Timer connect diagram.

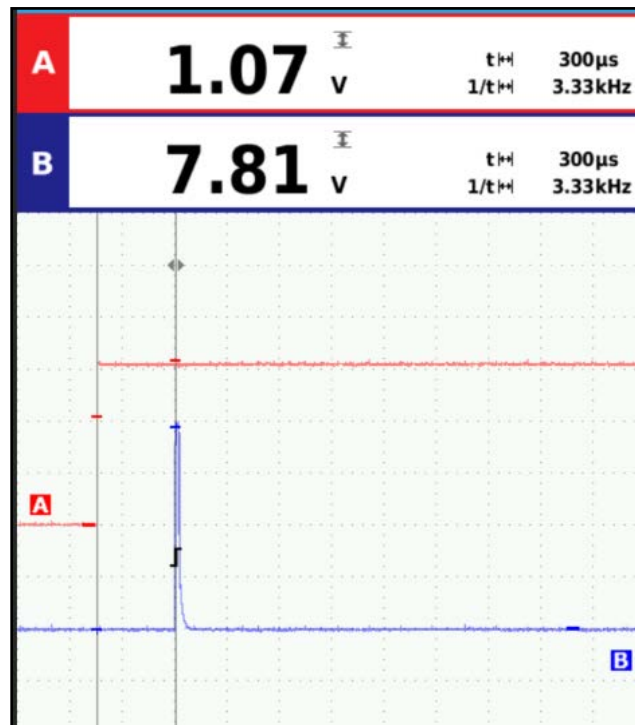

Figure 7. Time delay waveform of decoder high voltage release and detonation.

5.4. Compatibility Test for Engineering Seismograph

For the low velocity layer survey, the detonator is placed in the water of downhole and connects with GDZ24B seismometer by low-voltage composite detonation system. Geophones were planted on the ground near the well head.

The seismic record showed that the first arrival is clear and indicating that the electronic detonator can be normally activated underwater, the detonation system meets the requirements of micro-logging operation (Figure 10).

5.5. Seismic Acquisition Test and Quality Consistence Analysis

In order to verify the matching of electronic detonators and shaped explosives

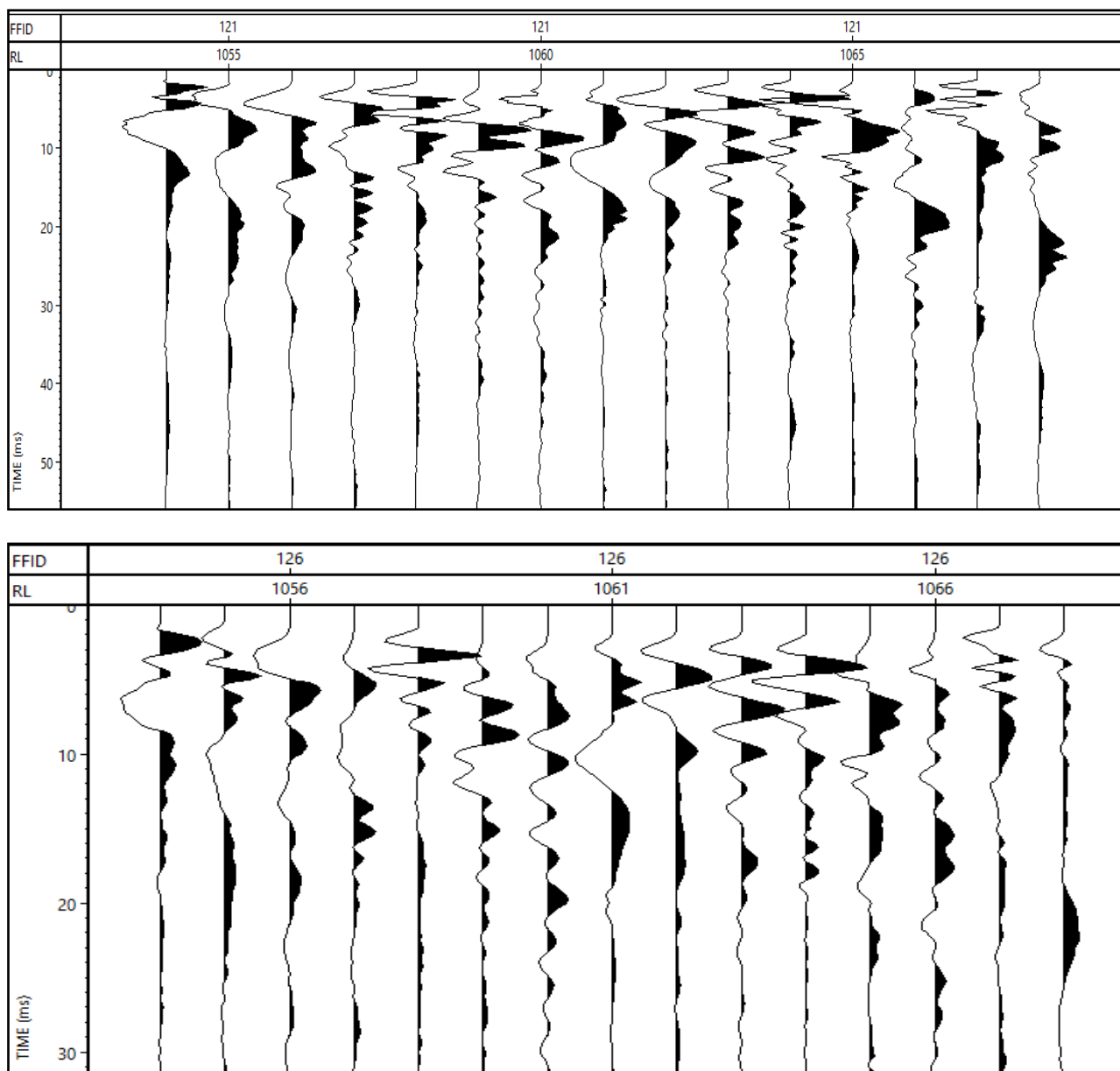

Figure 8. Seismic record of 15 electronic detonators blast together. (Top-type A Detonator, Bottom-type B Detonator)

for seismic exploration, Field tests were carried out on the Peng'an-Xichong 3D seismic survey project. The Geometry contains two parallel receive lines and three parallel shot lines. Two types of digital detonators and one conventional electric detonators are used respectively, and 30 shots are fired each.

The main construction parameters are shown in **Table 3 (Figure 11)**.

The Bandpass filter shown as follows. From left to right, it means Conventional electric detonator, type A and type B electronic detonators two by two. From top to bottom, the graph order is as fixed gain > AGC > 20 - 40 Hz > 30 - 60 Hz > 40 - 80 Hz > 50 - 100 Hz filter (**Figure 12**).

The graph below shows that the quality and energy of the data is equivalent (**Figure 13**).

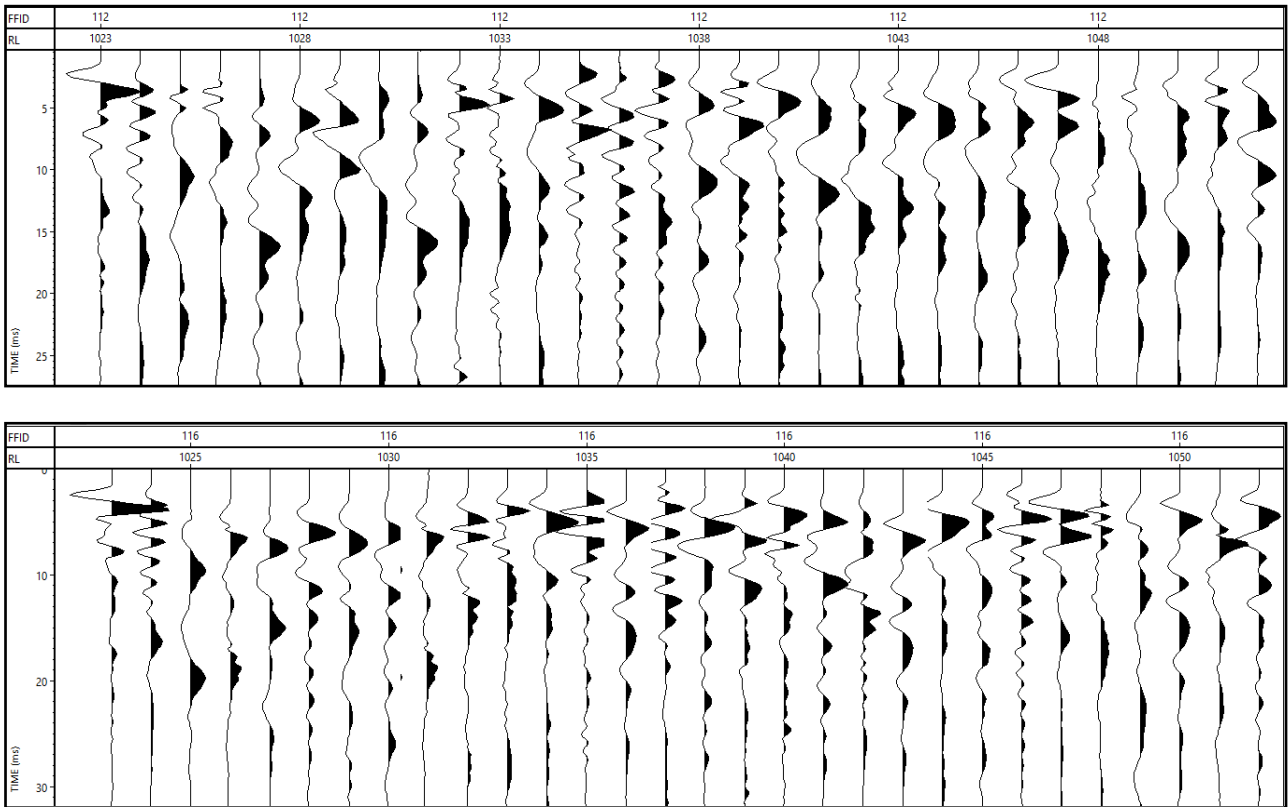

Figure 9. Seismic record of 30 electronic detonators blast together (Top-type A Detonator, Bottom-type B Detonator).

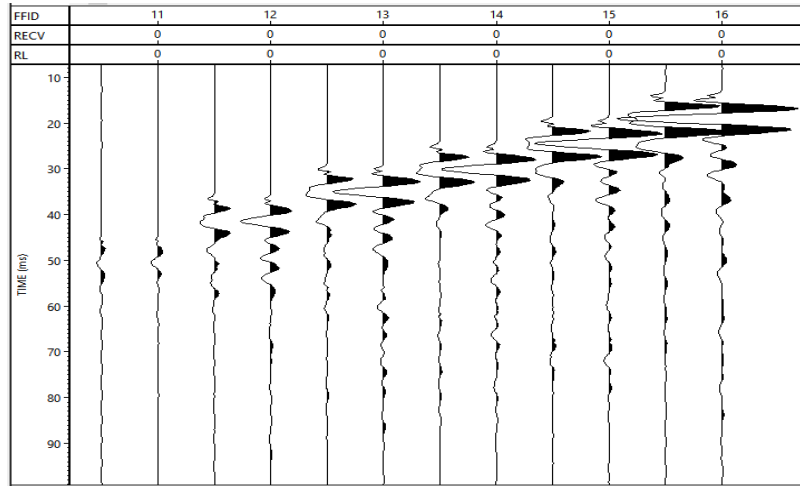

Figure 10. Raw data of GDZ24B seismograph.

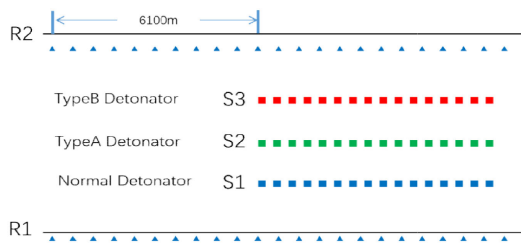
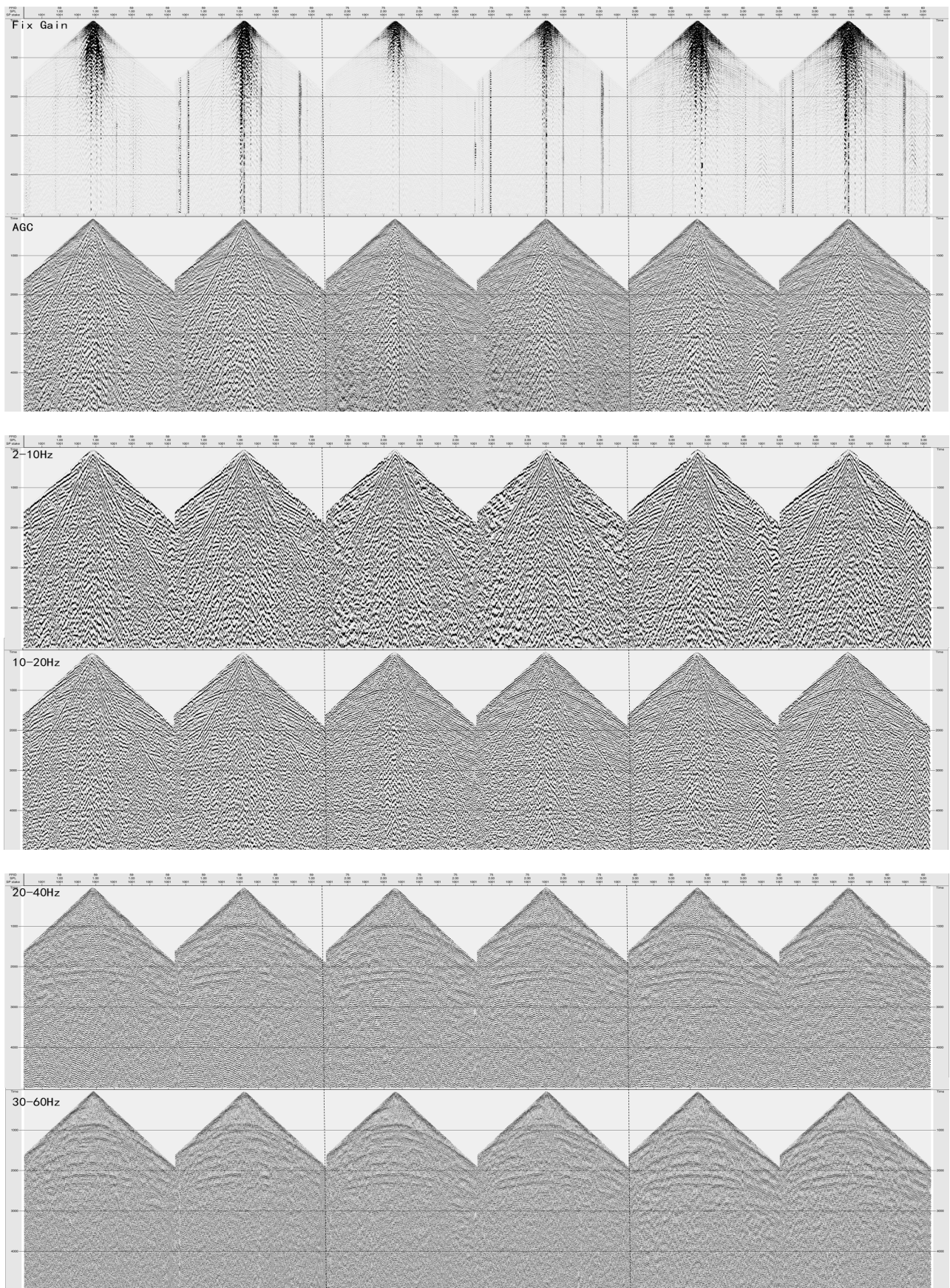

Figure 11. Geometry scheme of electronic detonators test.



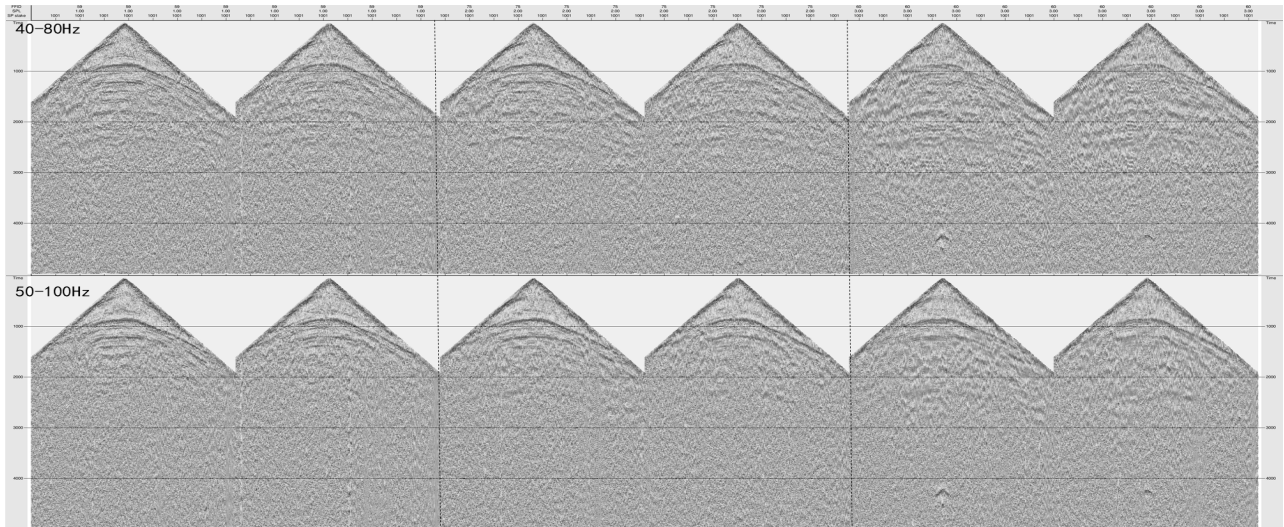

Figure 12. Bandpass filter of Raw data for three kinds of detonators. [Note: (Top-conventional detonator, middle-type A electronic detonator, Bottom-type B electronic detonator)].

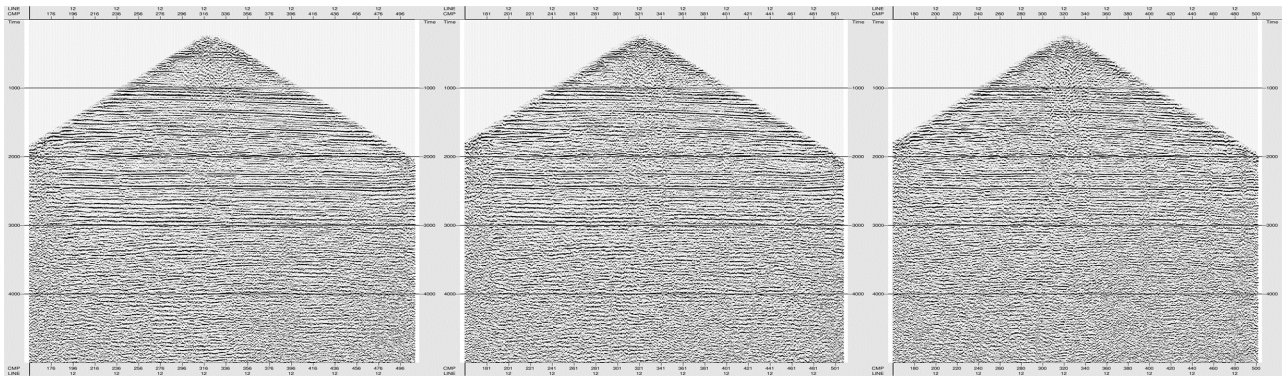

Figure 13. Horizontal superimposed profiles of three kinds of detonators. [Note: (Left-conventional electric detonator, middle-A type electronic detonator, Right-B type electronic detonator)].

Table 3. Seismic acquisition parameters.

Geometry (m)	6100 - 20 - 20 - 20 - 6100	Receivers per line	306
Shot space (m)	40	source line space (m)	40
Receiving space (m)	40	Receive line space (m)	200
record system	Node	record format	SEG-D
Low cut (Hz)	0	High cut Hz	400
sampling rate (MS)	1	record length (ms)	6000
hole depth (m)	12	charge (kg)	4

The brute stack profile of is as follows in **Figure 14**.

According to the line test brute stack section analysis (**Figure 13** and **Figure 14**), the horizons are consistency, the phase characteristics of the reflection horizon wave groups are similar; the shallow reflection events have no misalignment. It can be continuously tracked without phase distortion. It shows that the electronic detonator and supporting excitation system have relative stability.

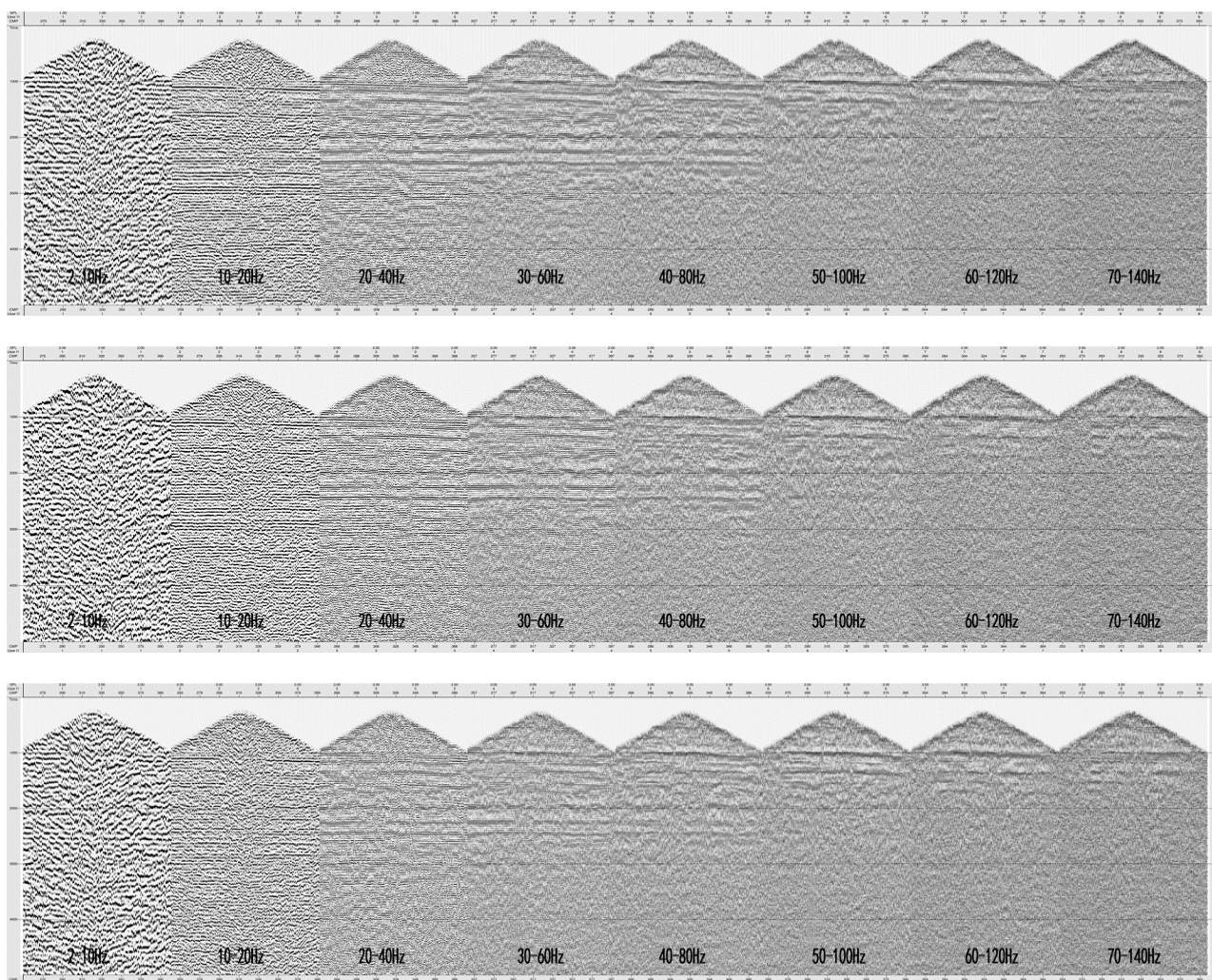

Figure 14. Bandpass filter of Brute stack sections of three types detonator. [Note: (Top-conventional detonator, middle-type A electronic detonator, Bottom-type B electronic detonator). Note: From left to right AGC > 10 - 20 Hz > 20 - 40 Hz > 30 - 60 Hz > 40 - 80 Hz > 50 - 100 Hz > 60 - 120 Hz > 70 - 140 Hz.

6. Conclusion

It has been proved that the electronic detonator is stable and reliable and the seismic data shoot by electronica detonator meet the specifications. For efficient production organization, the following tips are recommended:

- 1) Aiming at the development trend of large-scale application of wireless node recorders, the GPS timing accuracy of the detonator terminal must be improved.
- 2) In terms of material procurement, only one kind of electronic detonator should be used for each project.
- 3) For the production organization, in view of the 5 km radius constraint of the Danlingyun platform, resources should be organized in blocks near the source points.
- 4) For the short period of validity of the detonator key, one special person should take responsibility of collect detonator Key once the production progress is blocked.

Acknowledgements

This paper is a demonstration of field test in Seismic Crew 259 of CNPC. Thanks to all colleagues who participated in the project!

Conflicts of Interest

The authors declare no conflicts of interest regarding the publication of this paper.

References

- Cheng, G. H., & Wang, Y. (2020). Application and Prospect of Digital Electronic Detonator in Blasting Engineering. *Mining Engineering*.
- Deng, C. Y., & Zhang, H. Y. (2020). Digital Electronic Detonators and Their Promotion and Application, *Mining Technology*, 20.
- GB 8031 (2015). *Industrial Electric Detonators*.
- Hao, X. W. (2019). Research on the Application of Digital Electronic Detonators. *Contemporary Chemical Research*.
- Jiang, N. (2021). Digital Electronic Detonator (Metal Shell) Monitoring and Safety Management under Industrial Development. *Industry Development*.
- SY-T 6734 (2014). *Inspection Items and Technical Indicators of Remote Control Explosion Synchronization System for Seismic Exploration*.
- WJ 9085 (2015). *Industrial Digital Electronic Detonator*. The People's Republic of China Weapons Industry Standard.
- Yang, W., & Yue, C. X. (2021). Research on Antistatic Performance of Digital Electronic Detonator. *Explosive Technology*, No. 1.
- Yang, Y. (2020). Application of an Electronic Detonator in Petroleum Seismic Exploration. *China Petroleum and Chemical Standards and Quality*, 40.
- Zang, X. S. (2022). The Civil Explosive Industry Will Fully Use Electronic Detonators. Listed Companies Start a Battle for Production Capacity, *Securities Times*, 11th Edition, A06.