

# Research on Technical Pathways and Applications for Efficient Utilization of LNG Cold Energy

Li Lin<sup>1\*</sup>, You Yun<sup>2</sup>, Qin Xia<sup>3</sup>

<sup>1</sup>Chongqing Energy Utilization Monitoring Center (Chongqing Energy Saving Technology Service Center), Chongqing

<sup>2</sup>School of Petroleum Engineering and Natural Gas Technology, Chongqing University of Science and Technology, Chongqing

<sup>3</sup>Chongqing Instrument Factory, Manufacturing Company, CNPC Logging Co., Ltd., Chongqing

Email: \*highsky123@163.com

**How to cite this paper:** Lin, L., Yun, Y. and Xia, Q. (2026) Research on Technical Pathways and Applications for Efficient Utilization of LNG Cold Energy. *Energy and Power Engineering*, 18, 62-72. <https://doi.org/10.4236/epe.2026.181003>

**Received:** December 24, 2025

**Accepted:** January 24, 2026

**Published:** January 27, 2026

Copyright © 2026 by author(s) and Scientific Research Publishing Inc.

This work is licensed under the Creative Commons Attribution International License (CC BY 4.0).

<http://creativecommons.org/licenses/by/4.0/>



Open Access

## Abstract

China's annual LNG imports exceed 100 billion cubic meters, yet the substantial amount of high-grade cold energy released during its regasification remains largely unrecovered at scale, resulting in significant energy waste. The latent heat of LNG vaporization ranges from 820 to 890 kJ/kg, with each ton of cold energy theoretically convertible to approximately 240 kW·h of electricity, indicating considerable recovery potential. To achieve efficient conversion of this low-temperature cold energy, this study systematically evaluates the technical benefits across seven typical application scenarios—air separation, CO<sub>2</sub> capture, power generation, cold chain logistics, seawater desalination, and cryogenic grinding—based on the principles of temperature matching, cascade utilization, and cold storage for peak shaving. An integrated modular cold energy recovery system combining refrigeration and power generation has been developed for small-scale LNG stations with daily supply capacities below  $10 \times 10^4$  m<sup>3</sup>/d. Practical results confirm that this system effectively enhances comprehensive energy utilization efficiency, providing technical support for improving energy system performance, reducing carbon emissions across the industrial chain, and advancing the development of zero-carbon ports and green manufacturing systems.

## Keywords

LNG Cold Energy, Cryogenic Utilization, Recovery and Utilization, High Efficiency, Technology Integration

## 1. Introduction

At standard atmospheric pressure, natural gas undergoes a phase change from gas

to liquid at approximately  $-162^{\circ}\text{C}$ , forming liquefied natural gas (LNG) [1]. This liquefaction process significantly reduces its volume, substantially enhancing the economic efficiency and safety of storage and transportation. Consequently, LNG has progressively emerged as a crucial clean energy carrier in international energy trade. Against the backdrop of the “dual carbon” goals and the global transition toward greener energy, LNG continues to gain a larger share in global energy trade due to its low-carbon characteristics and supply flexibility. According to the China Natural Gas Development Report 2025, China’s total natural gas imports reached 181.7 billion cubic meters in 2024, of which LNG imports accounted for 105.7 billion cubic meters, reflecting a year-on-year increase of 7.7% [2]. This underscores the pivotal role of LNG in China’s energy mix. However, the cold energy resources inherent in LNG during storage, transportation, and regasification remain largely underutilized in most domestic projects, lacking large-scale and systematic recovery. From a life-cycle perspective, this results in notable energy loss and an efficiency gap.

From a thermodynamic perspective, the phase change of LNG involves dynamic variations in composition and physical properties, constituting a complex, multiphase, and transient system. A notable characteristic is its high vaporization latent heat, typically ranging from 820 to 890 kJ/kg [3]. For instance, when LNG at  $-162^{\circ}\text{C}$  under atmospheric pressure is warmed to  $25^{\circ}\text{C}$ , it absorbs approximately 920 kJ/kg of heat. Based on an ideal thermodynamic efficiency, the cold energy contained in one ton of LNG corresponds to about 240 kW·h of electrical energy. Therefore, the efficient recovery of this high-grade cold energy not only improves the overall energy system efficiency but also enables synergistic energy savings and emission reductions in various fields, including industrial refrigeration, low-temperature power generation, air separation, cold-chain logistics, and carbon capture. Consequently, investigating the benefits of efficient LNG cold energy recovery technologies holds significant importance for enhancing energy system efficiency, reducing carbon emissions across the entire industrial chain, and strengthening energy security and green competitiveness.

## 2. Analysis of LNG Exergy Characteristics

As a high-grade, low-temperature energy source, LNG cold energy can be recovered and utilized across various industrial and civilian applications, significantly reducing system energy consumption and operating costs. Exergy represents the maximum theoretical useful work potential of a system, reflecting the portion of energy that can be effectively utilized. Due to the temperature and pressure differences between LNG and its surrounding environment, the cold energy is essentially the energy obtainable from the phase change of LNG as it equilibrates with the surroundings. Therefore, exergy analysis provides a more effective means of evaluating both the quantity and quality of LNG cold energy.

The total exergy of LNG can be decomposed into thermal exergy ( $e_{x,t}$ ), pressure exergy ( $e_{x,p}$ ), and chemical exergy ( $e_{x,chem}$ ). Thermal exergy arises from thermal

imbalance at constant pressure, pressure exergy results from mechanical imbalance at ambient temperature, and chemical exergy is due to compositional differences with the environment. This relationship can be expressed as:

$$e_x(T, P) = e_{x,t} + e_{x,p} + e_{x,chem} \quad (1)$$

Among these components, the thermal exergy ( $e_{x,t}$ ) originates from the temperature difference between LNG and the ambient environment and is released during the vaporization process.

$$e_{x,t} = \left(1 - \frac{T_0}{T_s}\right)r + \int_{T_s}^{T_0} c_p \left(1 - \frac{T_0}{T}\right) dT \quad (2)$$

The pressure exergy ( $e_{x,p}$ ) arises from the storage pressure of LNG, accounting for a minor proportion of the total exergy and is generally negligible.

$$e_{x,p} = \left(pv - p_0v_0\right)\left|T_0\right) - \int_{p_0, T_0}^{p, T_0} p dv \quad (3)$$

The chemical exergy ( $e_{x,chem}$ ) originates from the calorific value of the hydrocarbon components, primarily released through combustion or chemical reactions.

$$e_{x,them} = \sum x_i e_{x,chem,i}^0 + RT_0 \sum x_i \ln(\gamma_i x_i) \quad (4)$$

In the equations above, the symbols are defined as follows:  $T_0$  denotes the ambient reference temperature (K);  $T_s$  represents the saturation temperature at which LNG phase change occurs (K);  $r$  is the latent heat of vaporization (kJ/kg);  $c_p$  indicates the specific heat at constant pressure (kJ/(kg·K));  $p$  is the actual pressure (MPa);  $p_0$  is the ambient reference pressure (MPa);  $v$  denotes the specific volume under actual conditions ( $p, T_0$ ) (m<sup>3</sup>/kg);  $x_i$  is the mole fraction of component  $i$ ;  $e_{x,chem,i}^0$  represents the standard chemical exergy of pure component  $i$  under standard conditions;  $\gamma_i$  is the activity coefficient of component  $i$ ;  $R$  is the universal gas constant.

It can be seen that, despite chemical exergy accounting for the predominant share, the recovery of thermal exergy remains valuable. Thermal exergy can be utilized directly at the low-temperature end (-162°C), requiring only equipment such as heat exchangers and expanders for its recovery. Although its proportion is small compared to chemical exergy, its recovery does not alter the chemical composition of LNG and still holds significant energy-saving potential and economic value.

### 3. Technical Pathways for LNG Cold Energy Utilization

Current main technical pathways for LNG cold energy utilization include air separation, carbon capture, cold energy power generation, cold chain storage and transportation, seawater desalination, etc. [4], as illustrated in **Figure 1**.

#### 3.1. Air Separation

Air separation is a critical industrial process for producing oxygen, nitrogen, argon,

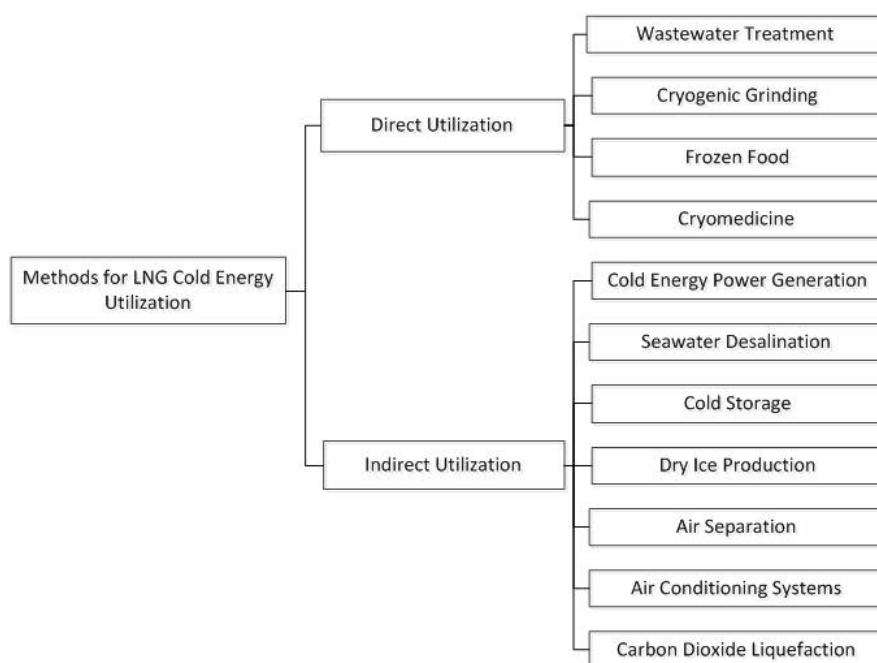

**Figure 1.** Methods for LNG cold energy utilization.

and other gases through cryogenic methods. Conventional air separation relies on mechanical refrigeration, where compression and expansion account for over 60% of energy consumption. The low-temperature cold energy released during LNG vaporization, ranging from  $-183^{\circ}\text{C}$  to  $-173^{\circ}\text{C}$ , aligns closely with the thermal demands of air separation and can serve as an efficient supplementary cooling source to reduce electricity usage. Currently, several representative processes have been established for LNG-integrated air separation technologies, primarily including:

1) Two-Stage Nitrogen Expansion System with LNG Cold Energy

This process utilizes LNG cold energy for multi-stage pre-cooling and expansion of nitrogen, reducing cycle power consumption. The comprehensive energy consumption per unit oxygen production can be lowered by 0.6271 to 0.8271  $\text{kW}\cdot\text{h}/\text{kg}$ , enabling annual electricity savings exceeding 10 million kilowatt-hours in large-scale air separation plants.

2) Three-Column Distillation System Integrated with LNG Cold Energy

Through heat exchange and structural optimization, multi-stage cold energy coupling is achieved. Simulation studies from literature [5] indicate that the energy consumption per unit product is reduced to 0.255  $\text{kW}\cdot\text{h}/\text{kg}$ , with a thermal efficiency of 71.65%, cold exergy efficiency of 53.18%, and an overall energy saving rate of 3.08% [5]. This technology lowers operational costs and reduces dependency on external electricity, enhancing system stability and flexibility.

### 3.2. Low-Temperature $\text{CO}_2$ Capture

Conventional CCUS technologies face challenges in large-scale deployment due to the high energy consumption associated with  $\text{CO}_2$  liquefaction and capture [6]. The temperature of LNG cold energy, which remains below  $-160^{\circ}\text{C}$ , can be effi-

ciently integrated with carbon capture systems in high-emission sectors such as power generation, steel, and chemical industries. Through cascaded utilization of cold energy, this integration reduces the energy required for CO<sub>2</sub> liquefaction and lowers equipment costs, thereby enhancing the economic feasibility of CCUS.

#### 1) O<sub>2</sub>/H<sub>2</sub>O Oxygen-Enriched Combustion System

This system utilizes LNG cold energy to condense water vapor and CO<sub>2</sub> in the flue gas from oxygen-enriched combustion, reducing power consumption for dehydration and compression. The integrated system achieves a thermal efficiency of 57.9% and an exergy efficiency of 42.7%, representing an improvement of 8–12% compared to conventional processes, while also decreasing cooling water consumption and equipment footprint.

#### 2) Rankine Cycle Integrated System

Using LNG cold energy as a low-temperature heat source, an organic Rankine cycle (ORC) is constructed with CO<sub>2</sub> or mixed working fluids to convert cold energy into electricity for driving carbon capture units. Simulation results from literature [6] show that the system achieves an exergy efficiency of 56.90% and a cold energy utilization rate of approximately 20.81%, demonstrating strong potential for energy integration and cascade utilization.

#### 3) Closed Brayton Cycle System

By integrating a closed Brayton cycle with the LNG cold source and employing helium or supercritical CO<sub>2</sub> as the working fluid, this system enables combined power and cooling generation. It attains an energy efficiency of 65.07% and an exergy efficiency of 53.7%, not only efficiently converting cold energy into power but also providing a stable cooling supply for CO<sub>2</sub> capture, offering high flexibility in system integration.

### 3.3. Cold Energy Power Generation

Cold energy power generation is a key pathway for achieving large-scale and efficient utilization of LNG cold energy. This technology converts cold energy into electricity based on temperature differences or low-grade waste heat, and is widely implemented in countries such as Japan. Statistics indicate that approximately 56% of cold energy at Japanese receiving terminals is utilized for power generation [7], underscoring its practical engineering value.

#### 1) Direct Expansion Power Generation System

This system utilizes pressurized vaporized natural gas to directly drive an expander for electricity generation, featuring a simple structure and low investment. However, limited by incomplete energy conversion, its thermoelectric efficiency is generally below 15%, making it suitable primarily for small-scale or auxiliary power generation.

#### 2) Rankine Cycle Power Generation System

Using organic working fluids such as propane, this system condenses the fluid via LNG cold energy, then evaporates it by absorbing ambient heat to perform work, thereby converting cold energy into electricity. With an efficiency typically

ranging from 20% - 25%, it is currently the most widely adopted LNG cold energy power generation method.

#### 3) Combined Cycle Power Generation System

By integrating direct expansion with the Rankine cycle, this system achieves cascaded utilization of cold energy. High-pressure stages employ direct expansion for power generation, while low-pressure stages incorporate the Rankine cycle, enhancing overall cold energy utilization. This approach can achieve a comprehensive cold energy utilization rate of up to 50%, with power generation efficiency significantly surpassing that of single-cycle systems.

#### 4) Kalina Cycle Power Generation System

Utilizing non-isothermal phase change characteristics, the Kalina cycle achieves superior thermodynamic matching between variable-temperature heat sources and cold sinks. Compared to conventional Rankine cycles, it offers higher exergy efficiency under large temperature differentials, making it well-suited for scenarios involving gradual temperature increases during LNG regasification.

#### 5) Brayton Cycle Power Generation System

Employing gases such as nitrogen or helium as working fluids, this closed cycle facilitates work-heat conversion. Owing to the high specific heat capacity and excellent heat transfer properties of gaseous media, the cycle significantly reduces compressor power consumption when integrated with the low-temperature LNG cold source, achieving system exergy efficiencies of 35% - 40%. It is particularly suitable for medium-to large-scale power generation facilities.

#### 6) Comprehensive Performance Comparison of Integrated Systems

Multi-cycle integrated systems generally outperform single Rankine cycles in terms of net power output and economic viability. For instance, a hybrid system combining the Rankine cycle with direct expansion not only enhances cold energy utilization but also reduces the levelized cost of electricity through optimized energy integration, thereby improving the economic feasibility of projects.

### 3.4. Low-Temperature Cold Storage

In sectors such as cold chain logistics, conventional electric-powered cold storage systems entail high energy consumption and operating costs. The temperature range of LNG cold energy ( $-162^{\circ}\text{C}$  to ambient) aligns well with the requirements of low-temperature cold storage, enabling it to serve as an efficient cooling source that supplements or replaces conventional refrigeration, thereby significantly reducing energy use. Engineering practices demonstrate that indirect heat exchange systems utilizing LNG cold energy achieve an exergy efficiency of 54%, with electricity savings exceeding 40% and operating costs reduced by approximately 35%. The investment payback period is typically 3 - 5 years, offering both economic and low-carbon benefits. This approach is well-suited for applications such as port-side cold chains and regional logistics hubs.

### 3.5. Seawater Desalination

Seawater desalination serves as a crucial method to alleviate freshwater scarcity,

yet conventional processes such as freezing and membrane distillation are often energy-intensive. LNG cold energy can act as a low-temperature cooling source, reducing both system energy consumption and operating costs. In freezing methods, it directly cools seawater and facilitates ice formation, displacing part of the mechanical refrigeration load and lowering the energy required for water production. In membrane distillation, it enhances condensation efficiency and increases freshwater yield. Operational data indicate that integrating LNG cold energy can reduce system energy consumption by 20% - 30% and cut operating costs by 15% - 25%. This technology is particularly suitable for coastal areas near LNG receiving terminals, supporting synergistic supply of energy and water resources.

### **3.6. Refrigeration and Air Conditioning**

The cascaded utilization of LNG cold energy in refrigeration and air conditioning involves recovering the high-grade cold energy released during LNG regasification, which can directly or indirectly replace conventional mechanical refrigeration systems, significantly reducing energy consumption and carbon emissions in related applications.

#### 1) Cold Storage-Based LNG-Powered Air Conditioning System for Heavy-Duty Trucks

This system utilizes the cold energy from onboard LNG fuel vaporization, coupled with a cold storage unit, to provide cooling for the driver's cabin. It addresses the high fuel consumption and emissions associated with traditional air conditioning, reducing summer cooling energy use in heavy-duty trucks by 15% - 20% and improving overall vehicle energy efficiency.

#### 2) Marine Air Conditioning System

Taking a 3000-ton LNG-diesel dual-fuel vessel as an example, this technology recovers cold energy from LNG vaporization in both main and auxiliary engines. Through a refrigerant circulation system, it supplies cooling to crew living quarters and engine rooms. This integrated solution achieves approximately 54% energy savings for air conditioning during typical voyages, significantly reducing electrical load.

#### 3) Refrigeration System for Cold-Chain Transport Vehicles

In medium- and short-distance cold-chain transport, LNG cold energy can replace conventional diesel-powered refrigeration to provide stable cooling for refrigerated compartments. This system reduces fuel consumption and exhaust emissions while enhancing the stability of the refrigeration system, lowering energy consumption by 25% - 30%. It is well-suited for urban distribution and regional logistics scenarios with high environmental requirements.

### **3.7. Cryogenic Grinding**

Cryogenic grinding involves cooling materials below their glass transition temperature to enhance grinding efficiency and product quality. Conventional liquid nitrogen refrigeration is energy-intensive. LNG cold energy can be integrated with

liquid nitrogen systems to provide a stable and efficient low-temperature cooling source, significantly reducing energy consumption. This technology has been applied in processing materials such as tire rubber powder and food ingredients, achieving a system exergy efficiency of 77.94%—representing a 15% - 20% improvement over traditional methods. Beyond energy savings, it also improves product particle size and physical properties, delivering notable economic and environmental benefits.

#### 4. Case Study on Cold Energy Applications at a Small Scale LNG Station

Taking a small-scale LNG station with a daily supply capacity of less than 100,000 cubic meters as an example, limited cold energy recovery potential and output instability are observed due to supply constraints and load fluctuations. In such scenarios, a modular cold energy recovery system integrating refrigeration and power generation was designed, with the process flow shown in **Figure 2**. The integrated system demonstrates the potential to enhance comprehensive energy efficiency through the cascade utilization of cold energy released during LNG vaporization. The system prioritizes meeting the refrigeration demands of the station and nearby cold chain logistics centers while ensuring stable gas supply, with the remaining cold energy used to drive an organic Rankine cycle (with R290 as the working fluid) for power generation.

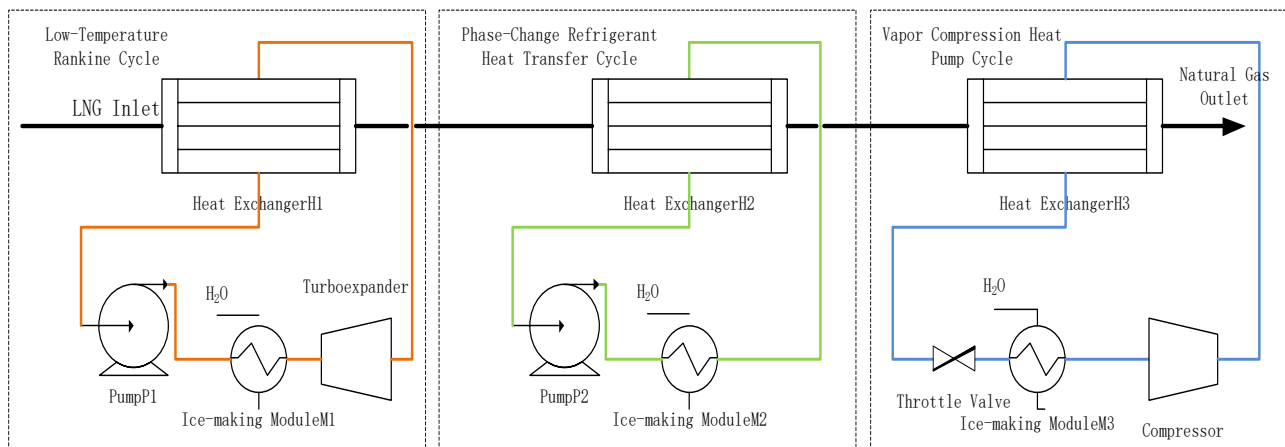

**Figure 2.** LNG cold energy refrigeration and power generation process.

At present, the station operates with a vaporization pressure of 0.8 MPa and an ambient temperature based on the local annual average of 15°C (with summer highs of 35°C and winter lows of -5°C). Approximately 60% of the total cold energy is allocated to refrigeration (including ice-making and cold storage), while the remaining 40% is used for power generation. Following implementation, the system has demonstrated the following performance characteristics:

1) Enhanced cooling capacity. By effectively utilizing LNG cold energy, the system increases chilled water production. Practical results indicate that such systems

can achieve significant energy savings in the refrigeration stage through optimized heat exchange processes.

2) Additional power generation from cold energy. After meeting the primary cooling demand, surplus cold energy is channeled to drive the power generation unit, enabling cascaded energy utilization and yielding supplementary electricity output.

3) Coordinated regasification and energy output flow. Following pressurization, vaporization, and cold energy extraction on-site, the natural gas is fed into the pipeline network. This integrated workflow ensures stable and synergistic operation of both gas supply and cold energy recovery.

4) Utilization of circulating water cooling. The system pre-cools or deeply cools circulating water using LNG cold energy, effectively reducing the electrical cooling load for subsequent air-conditioning or industrial cooling processes.

Simulation results show that the system achieves an overall cold energy utilization rate of 68.5% and an exergy efficiency of 31.2%. Compared to a baseline scenario without cold energy recovery, the modular approach reduces the overall energy consumption of the vaporization station by approximately 25%. These findings are consistent with the operational data trends reported in literature [8] for small-scale stations, which noted an approximately 8.5% improvement in refrigeration capacity and a 6.46% increase in power generation [8]. This indicates that even under the limited cold energy conditions of small LNG stations, effective utilization of cold energy for ice-making, cold storage, and auxiliary power generation can be achieved through reasonable system design and operational optimization, demonstrating favorable energy-saving benefits and engineering applicability.

## 5. Development of LNG Cold Energy Utilization Systems

To enhance LNG cold energy utilization efficiency, broaden its application scope, and promote energy structure optimization, the following development directions are proposed based on current technological status and practical needs.

### 5.1. System Optimization and Process Upgrading

Environmentally friendly mixed working fluids, such as propane-isobutane, are prioritized to optimize heat exchange processes and equipment matching, reduce irreversible heat transfer losses, and enhance system exergy efficiency. It is important to note that hydrocarbon working fluids like propane are flammable. In small-scale applications, especially in proximity to densely populated areas, strict safety protocols must be established. These include adhering to explosion-proof standards such as ATEX/IECEx in system design, employing explosion-proof motors and electrical equipment for critical components, and implementing intelligent control systems to dynamically adjust operations based on real-time load and meteorological conditions, ensuring efficient and stable system performance.

## 5.2. Integration of Energy Storage Technology and Operational Flexibility Enhancement

To address the volatility in gas supply and instability of cold energy output at LNG receiving terminals, research and development of cold storage materials and devices should be advanced to establish systems for storing and releasing cold energy. By leveraging cold storage units for load-shifting, the continuity and reliability of cold energy supply can be improved, mitigating pipeline fluctuations and enhancing system operational flexibility and energy utilization efficiency.

## 5.3. Expansion into New Application Fields and Integrated Innovation

Active research should be conducted on the application of LNG cold energy in emerging areas, including its use in data center cooling to reduce the Power Usage Effectiveness (PUE) value, introducing low-temperature cold energy into wastewater treatment to enhance energy efficiency, and promoting its adoption in logistics parks, urban cold chain systems, and district cooling networks to improve comprehensive energy utilization.

## 6. Conclusions and Outlook

1) Following the principles of temperature matching and cascade utilization, mature technological frameworks for LNG cold energy utilization have been developed across air separation, carbon capture, combined cooling and power generation, cold chain logistics, seawater desalination, and data center cooling. For instance, integrating LNG cold energy into a dual stage nitrogen expansion and three column distillation system in air separation reduces specific oxygen production energy consumption to  $0.252 \text{ kW}\cdot\text{h}\cdot\text{kg}^{-1}$ , achieving energy savings exceeding 30%. In combined cycle power generation, cold energy utilization efficiency reaches 50%, with exergy efficiencies of 35% - 40%, highlighting strong potential for broader adoption.

2) Although many projects still exhibit limited energy efficiency due to load fluctuations and constraints in cold storage technology, operational practices at small scale LNG stations demonstrate that integrating ice making with power generation units enhances both ice production per unit mass of LNG vaporized and net power output. This confirms the technical feasibility of modular, integrated utilization under limited cold energy conditions.

3) The efficient utilization of LNG cold energy is advancing from single mode power generation demonstrations toward deeper, multi scenario integration. Future technological progress should focus on adopting environmentally friendly mixed working fluids, optimizing heat exchange process compatibility, and incorporating high density cold storage technologies to enhance system exergy efficiency and operational flexibility.

## Conflicts of Interest

The authors declare no conflicts of interest regarding the publication of this paper.

## References

- [1] Wang, G.F., Qian, Y. and Zhao, C.L. (2024) Fundamentals of LNG Storage and Transportation. Chemical Industry Press.
- [2] National Energy Administration (2025) China Natural Gas Development Report (2025). Petroleum Industry Press.
- [3] Wu, X.H., Cai, L., Li, T.Y., *et al.* (2017) Latest Advances in LNG Cold Energy Utilization Technologies. *Oil & Gas Storage and Transportation*, **36**, 624-635.
- [4] Chen, C., Kan, A.K., Yang, F., *et al.* (2017) Simulation Study on Cold Storage Refrigeration in Fishing Vessels Using LNG Cold Energy. *Low Temperature and Specialty Gases*, **35**, 11-15.
- [5] Fan, S.S., Wang, Y.H. and Lang, X.M. (2020) New Technologies for Natural Gas Utilization. Chemical Industry Press.
- [6] Li, L. and Fang, B. (2024) Development of CO<sub>2</sub> Capture, Utilization and Storage Technologies in the Context of Green Economy. *Energy Conservation*, **43**, 91-93.
- [7] Du, H.Y. (2025) Analysis on the Application Prospects of Cold Energy Power Generation in LNG Terminal Projects. *Chemical Engineering Design Communications*, **51**, 136-138.
- [8] Gong, M.Y., Cai, L., Xu, L.H., *et al.* (2021) Integrated System for Ice-Making and Power Generation Using Cold Energy from Small-Scale LNG Vaporization Stations. In: *Proceedings of the 11th China Gas Operation and Safety Seminar & 2021 Annual Academic Conference of the Gas Branch of China Civil Engineering Society (Volume I)*, Foran Energy Group Ltd, 311-321.